

Josip Juraj Strossmayer University of Osijek



Faculty of Education



Department of Mathematics

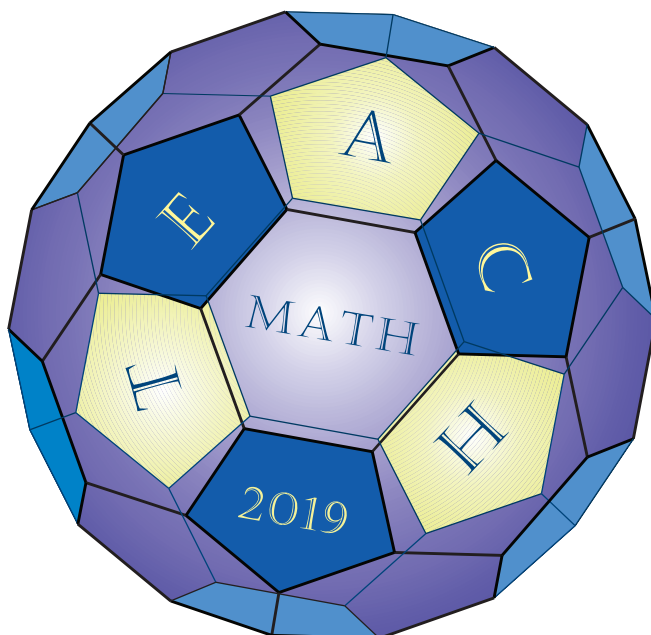

TOWARDS NEW PERSPECTIVES ON MATHEMATICS EDUCATION

Editors:

Zdenka Kolar-Begović
Ružica Kolar-Šuper
Ljerka Jukić Matić

2019

ELEMENT

Josip Juraj Strossmayer University of Osijek
Faculty of Education and Department of Mathematics

Sveučilište Josipa Jurja Strossmayera u Osijeku
Fakultet za odgojne i obrazovne znanosti i Odjel za matematiku

TOWARDS NEW PERSPECTIVES ON MATHEMATICS EDUCATION

**PREMA NOVIM PERSPEKTIVAMA
MATEMATIČKOG OBRAZOVANJA**

monograph

Editors:

**Zdenka Kolar-Begović
Ružica Kolar-Šuper
Ljerka Jukić Matić**

Osijek, 2019

International Scientific Committee

Josip Juraj Strossmayer University of Osijek

Zdenka Kolar-Begović
Ružica Kolar-Šuper
Ljerka Jukić Matić
Rudolf Scitovski
Kristian Sabo
Ivan Matić
Nenad Šuvak
Ana Mirković Moguš

University of Zagreb

Željka Milin Šipuš
Aleksandra Čižmešija
Dubravka Glasnović Gracin

Foreign universities

Emil Molnár (Hungary)
Tatjana Hodnik (Slovenia)
Ana Kuzle (Germany)
Anders Hast (Sweden)
Edith Debrenti (Romania)
Ljiljanka Kvesić (Bosnia and Herzegovina)

Editorial Board

Emil Molnár (Hungary)
Tatjana Hodnik (Slovenia)
Ana Kuzle (Germany)
Anders Hast (Sweden)
Zdenka Kolar-Begović (Croatia)
Ružica Kolar-Šuper (Croatia)
Ljerka Jukić Matić (Croatia)
Edith Debrenti (Romania)
Ljiljanka Kvesić (Bosnia and Herzegovina)

Monograph referees

Nataša Macura (USA)
Vladimir Volenec (Croatia)
Šime Ungar (Croatia)

Supported by

Faculty of Education, University of Osijek

Damir Matanović, Dean

Department of Mathematics, University of Osijek

Kristian Sabo, Head of Department

A word from the Editorial Board

The world of teaching and learning mathematics is changing very rapidly, and technology presents a major factor that influences the direction of change. The development of technology is challenging the traditional views of the curriculum, teaching, learning, and assessment. In this situation, various questions arise as to what forms of curriculum, teaching, learning, and assessment are most appropriate or how teachers can keep up with developments and cope with their excessive teacher workload.

The question of integrating technology into mathematics education is not an easy one. This integration must certainly be wisely designed and implemented. On the one hand, technology is welcome to help us visualize mathematics, but sometimes it presents a hindrance to the teaching process. Issues connected with technology, online and other forms of distance learning, are frequently discussed among researchers, not only in mathematics education, but also in all domains that tackle education. There is concern that despite good potential of new technology, its improper use would result in education becoming even more unsatisfactory than it is now (Clements, Keitel, Bishop, Kilpatrick, Leung, 2013).

Mathematics teachers always stream toward better students' achievements. Textbooks are often the most influential curriculum materials, and as such, they have the potential to impact the way we teach and learn mathematics. Analysis of curriculum materials, like textbooks, provides insight into the opportunities to learn mathematics; what is accessible to students, when, how and to what extent. But such analysis alone is not enough to explain students' achievements. Researchers have identified multiple factors that have an impact on student learning: student-level factors (e.g., students' home background, their socioeconomic status, and gender differences), teacher- or classroom-level factors (e.g., peer influence, teacher quality, and teachers' instructional approaches), and contextual or school-level factors (e.g., the location of the school, the number of desks) (Son & Diletti, 2017).

As mathematics educators and researchers, we can and should have influence on one of those factors, namely teachers. Research has identified teachers as one of the most critical targets in various education reforms. Moreover, teachers' continuing professional development and learning are the best ways to improve education (Desimone, 2009). The effective teacher should use multiple methods of assessment to engage students in the learning process, monitor learner progress, and guide his/her and learner decision. The effective teachers should know how to implement active learning methods and redesign tasks to obtain more useful tasks for their students and intended learning outcomes.

A way to ensure teacher lifelong development and learning is through continuous professional development. But we must be careful when offering teacher training events labelled as professional development. Traditional workshops and professional conferences are ineffective routes for sustained growth (Ball & Cohen,

1999). Quality professional development must include teachers' active learning, collaboration with other teachers, coherence and duration, and it must be content-focused (Desimone, 2009).

Hence, teachers' professional development, if effective, can influence students' achievements in the long run. From a national perspective, it is important to have mathematically competent citizens. A vast body of research exemplifies that strong economies have a mathematically competent citizenry. By improving teachers, we improve students, and consequently we improve our nations.

References

- [1] BALL, D. L., & COHEN, D. K. (1999). Developing practice, developing practitioners: Toward a practice-based theory of professional education. In L. Darling-Hammond & G. Sykes (Eds.), *Teaching as the learning profession: Handbook of policy and practice* (pp. 3–32). San Francisco: Jossey-Bass.
- [2] CLEMENTS, M. A., KEITEL, C., BISHOP, A., KILPATRICK, J. & LEUNG, F. K.S. (2013). *Third International Handbook of Mathematics Education*. Dordrecht: Springer.
- [3] DESIMONE, L. (2009). Improving Impact Studies of Teachers' Professional Development: Toward Better Conceptualizations and Measures. *Educational Researcher*, 38(3), 181–199.
- [4] SON, J.W. & DILETTI, J. (2017). What Can We Learn from Textbook Analysis? In J. W. Son, T. Watanabe & J. J. Lo (Eds.), *What matters? Research trends in international comparative studies in mathematics education* (pp. 3–32). Cham: Springer.

Osijek, May 2019

Zdenka Kolar-Begović

Ružica Kolar-Šuper

Ljerka Jukić Matić

Contents

Preface	3
----------------------	---

1. Research on visualization and mental imagery in mathematics education

Ana Kuzle

What can we learn from students' drawings? Visual research in mathematics education	7
---	---

Eleonóra Stettner

Relationship between the Poly-Universe Game and mathematics education	36
---	----

Nikolina Kovačević

The use of mental geometry in the development of the geometric concept of rotation	60
--	----

Maja Cindrić, Irena Mišurac Zorica, Josipa Jurić

From “calculation in mind” till “mental calculation”	74
--	----

2. Fostering geometric thinking

Emil Molnár, István Prok, Jenő Szirmai

From a nice tiling to theory and applications	85
---	----

Zdenka Kolar-Begović, Ružica Kolar-Šuper, Ivana Đurđević Babić, Diana Moslavac Bičević

Pre-service teachers' prior knowledge related to measurement	107
--	-----

Sanela Nesimović, Karmelita Pjanić

Teachers' opinions on geometric contents in the curriculum for the lower grades of primary school	123
---	-----

Sanela Nesimović, Karmelita Pjanić

Geometric thinking of primary school pupils	135
---	-----

3. The role of mathematics textbooks and mathematics teacher resources

Ljerka Jukić Matić, Dubravka Glasnović Gracin

The influence of teacher guides on classroom practice	149
---	-----

<i>Željka Milin Šipuš, Ana Katalenić, Aleksandra Čižmešija</i> Redesigning a contextual textbook task with an exponential-type function using a posteriori analysis of the prospective mathematics teachers' work	173
--	-----

<i>Matea Gusić</i> Investigating adaptive reasoning and strategic competence in Croatian mathematics education: The example of quadratic function	192
---	-----

<i>Tihana Baković, Goran Trupčević, Anđa Valent</i> Treatment of initial multiplication in textbooks from Croatia and Singapore	216
---	-----

<i>Amanda Glavaš, Azra Staščik, Ljerka Jukić Matić</i> What types of knowledge do mathematics textbooks promote?	229
---	-----

4. Approaches to teaching and learning mathematics

<i>Zoltán Kovács and Eszter Kónya</i> How do novices and experts approach an open problem?	245
---	-----

<i>Sanja Rukavina</i> Preservice mathematics teachers and teacher research	261
---	-----

<i>Edith Debrenti and Balázs Vértessy</i> Mathematical problem solving in practice	270
---	-----

<i>Josipa Jurić, Irena Mišurac, Maja Cindrić</i> Student competence for solving logical tasks	285
--	-----

<i>Sead Rešić, Fatih Destović, Alma Šehanović, Amila Osmić</i> Problems and problem situation at the teaching topic example "Number divisibility and applications"	294
--	-----

5. The using of ICT in teaching and learning

<i>Karolina Dobi Barišić</i> Teaching with the use of ICT - how teachers perceive their own knowledge?	309
--	-----

<i>Ivana Đurđević Babić, Dajana Sabolić</i> Mining students' viewpoints about programming in primary education ...	324
---	-----

<i>Ana Mirković Moguš</i> The role of online applications as a tool of support in mathematics education	333
---	-----

<i>Josipa Matotek</i>	
Computer-based assessments in mathematics at the higher education level	342
<i>Ksenija Romstein</i>	
Technology use in early childhood	355
Index	365

TOWARDS NEW PERSPECTIVES ON MATHEMATICS EDUCATION

monograph

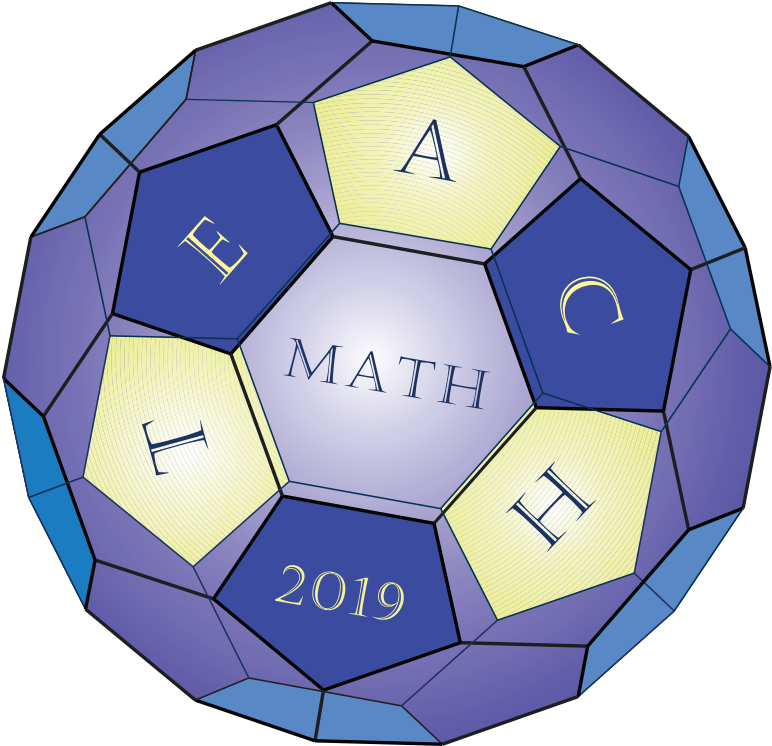

Preface

The content of the papers in the Monograph is related to teaching and learning mathematics, which can enrich knowledge and experience of students, teachers and prospective teachers. The Monograph consists of five chapters.

In the first chapter of the Monograph, the authors studied the importance of visual research in education. The first paper discusses the possibilities of using drawings in mathematics education research and it is focused on participant-produced drawings as a window into students' perceptions of geometry classroom learning milieu from a cognitive, social, and emotional perspective. The second paper presents the results of one project whose main objective is to develop a new visual system for mathematics education, i.e., the Poly-Universe Methodology. Poly-Universe lies in the "scale-shifting" symmetry inherent to its geometric forms and a colour combination system, which can be used universally, especially in the teaching of geometry and combinatorics. In the third paper in this chapter, the author studies the use of mental geometry in the development of the geometric concept of rotation and emphasizes that mental geometry helps students solve many geometric problems. In the fifth paper, the authors emphasize the calculation in mind and the forms of its emergence through the history of teaching mathematics in schools in the territory of today's Republic of Croatia, by analyzing the textbook and methodological literature.

In the second chapter, the authors discuss presentation group theory in a geometric language, points out that this visualization has many benefits, e.g., for attractive geometric problems. In the paper about the adoption of the concept related to measurement, the authors emphasize, as a result of the conducted research, that special attention in teaching mathematics should be paid to this concept which contributes to better understanding and linking of geometry and real life. In the third paper, the authors investigate teachers' opinions on geometric contents in the curriculum for the first five grades of primary school education as well as the quality of mathematics textbooks for the first five grades regarding the geometric contents. The aim of the last paper is to examine whether the elements of different geometric thinking levels according to van Hiele can be identified in pupils in the lower grades of primary school in the conducted research.

The third chapter contains papers which are thematically related to the use of textbooks and teacher resources in mathematics education. The role of teacher guides in teacher's classroom practice and their influence on the textbook use is studied in the first paper. A horizontal asymptote is a prominent feature of an exponential function graph. The second paper gives a comprehensive study within the Anthropological Theory of the Didactic on asymptotes and asymptotic behaviour

in the context of upper secondary mathematics education in Croatia. The investigation of two strands, i.e., adaptive reasoning and strategic competence in Croatian mathematics education regarding quadratic functions, is presented in the third paper in this chapter. In the next paper, the authors compare the treatment of initial multiplication learning, including the multiplications table, in textbooks from Croatia and Singapore. The last paper reports a study on the type of mathematical tasks and their overall representation in mathematics textbooks.

The fourth chapter covers papers devoted to some approaches to teaching mathematics. In the first paper, the authors examine the novices' and experts' approach an open problem. The readiness of a pre-service teacher to be an active participant in the changing of the educational process is discussed in the second paper in this chapter. The basic mathematical knowledge, ways of thinking and strategies used for solving unconventional problems are discussed in the third paper. The aim of the fourth paper is to examine students' success in solving logical problems in relation to the level of mathematical education (elementary and secondary school classes). In the last paper in this chapter, the authors explore the educational effects of one of the educational methods, i.e., problem learning.

The fifth chapter of this Monograph gives papers referring to the use of ICT. In the first paper, the author discusses the mutual influence of the teacher's understanding of educational technology, pedagogical and content knowledge for the purpose of effective application of educational technology in teaching. The second paper gives an acceptable classification model used for distinguishing between students sharing the opinion that pupils should be acquainted with basic programming concepts during lower grades of primary education, and those students who do not share this opinion. The aim of the third paper is to review the research on the use of online applications for teaching and learning mathematics. The results of the review imply a basis for choosing a framework for evaluation and informing teaching decisions about the use of applications to enhance students' conceptual understanding. The fourth paper points out the differences between paper-and-pencil and computer-based assessments. It highlights the advantages and disadvantages of using computer-based assessments in mathematics at the higher education level. In the last paper in this chapter, the author presents how parents and preschool teachers perceive technology use in early childhood, i.e., children up to seven years of age.

Zdenka Kolar-Begović

Ružica Kolar-Šuper

Ljerka Jukić Matić

1.

Research on visualization and mental imagery in mathematics education

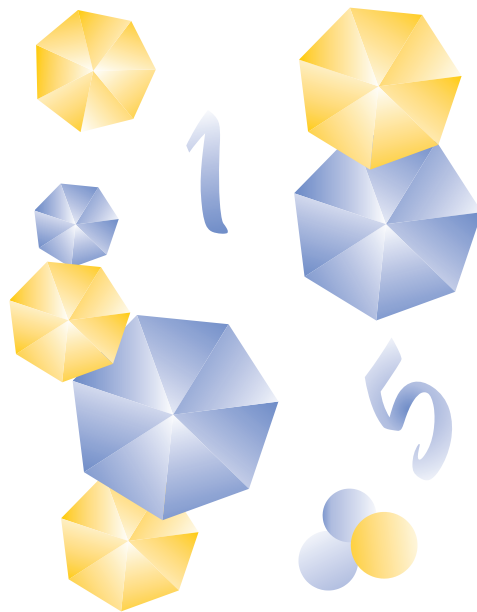

What can we learn from students' drawings? Visual research in mathematics education

Ana Kuzle

Department of Primary Mathematics Education, University of Potsdam, Potsdam, Germany

Abstract. Over the last twenty years, visual research methods became somewhat mainstream across social science research. Visual research methods incorporate some kind of imagery (e.g., drawings, photographs, videos) into the research process, which then constitute data used to communicate the research results. The roots of visual research stem from social sciences with a focus on the psychological stance of describing children's drawings in terms of developmental sequences. Recently, however, the focus shifted onto using drawings as expressions of meaning, understanding, and affect in (mathematics) education. Especially, participant-produced drawings allow a constructive process of thinking in action, rather than seeing drawings as simple representations of the participant's world. In this paper, I discuss the possibilities of using drawings in mathematics education research. Concretely, I focus on participant-produced drawings as a window into students' perceptions of geometry classroom learning milieu from a cognitive, social, and emotional perspective.

Keywords: drawings, fundamental ideas, classroom social climate, emotional atmosphere, visual research

1. Introduction

To date, various methods have been employed to research different mathematical phenomena, such as interviews, observations, and questionnaires. However, recent research has shown that creative methods, such as storytelling, drama, and drawings can help young participants describe their individual lived experiences, and give meanings to them more significantly than questionnaires and interviews (e.g., Einarsdóttir, 2007; Veale, 2005). With respect to visual research, drawings, videos, and photographs have been recognized as one of the crucial methods (Einarsdóttir, 2007). According to Thomson (2008), and Weber and Mitchell (1996), with visual methods things can be expressed that cannot be easily verbalized, as they require

little or no language mediation, which is an important aspect when working with young children. Similarly, this was emphasized by Hannula (2007), who stated that it is not easy to get verbally rich answers to questions from young children since they tend to give monosyllabic answers to questions they do not consider relevant to them. In addition, they may have difficulties with reading surveys and expressing themselves clearly in writing or within interview contexts due to talking with an often relatively unknown researcher. As such, these methods have shown not to be always reliable due to participants' young age (e.g., Einarsdóttir, 2007; Pehkonen, Ahtee, & Laine, 2016). Visual methods are not only effective because of the richness of produced data, but also because of the quality of the data providing insights into children's everyday lives (e.g., Einarsdóttir, 2007). Drawings as a visual research method are understood as "visual data that can give insight into how children view things" (Einarsdóttir, 2007, p. 201), which provide many benefits, such as a non-verbal focus for expression, familiarity with the method, and flexibility of the method (Malchiodi, 1998). However, "children's drawing is under-valued, under-researched and misunderstood within the domains of childhood studies and early childhood education (Anning & Ring, 2004, p. xi).

In this paper, I first discuss visual research from a theoretical perspective. In the second part, attention is given to drawings as a visual research method in mathematics education. In the third part, I outline three studies that focused on the analysis of students' perceptions of geometry classroom learning milieu from a cognitive, social, and emotional perspective by using participant-produced drawings. In the last section, I draw conclusions on using drawings in mathematics education research with regard to their theoretical and practical implications.

2. Visual research: theoretical foundation

This section is divided into two parts. I first present the construct of mental images. Developmental stages in drawing are then discussed.

2.1. Mental images

In cognitive science, a mental image is defined as a representation of the physical world (e.g., an object, an event, a situation) in a person's mind (Eysenck, 2012) whose features are spatially and temporarily organized (Kosslyn, 1988). The formation of a mental image is based on direct experience with its referent, but occurs when the relevant object, event or situation is not present (Eysenck, 2012). From the perspective of the theory of imagery, mental images are short-term memory representations generated from long-term memory representations that may be stored in a depictive (pictorial) or propositional (symbolic, language-like) format, regardless of the content (e.g., Kosslyn, 1980; Person & Kosslyn, 2015). As such, images are not present all the time, but only occur in specific circumstances. Tulving (1972) suggested that there are two parallel and partially overlapping information processing systems. Episodic memory entails a conscious experience of a unique

kind having an autobiographical nature (storage of specific experience and events which occurred at a particular time in place). Semantic memory, on the other hand, refers to general knowledge not attributable to specific learning episodes that an individual has accumulated through life. Thus, one can distinguish between different types of image representations (e.g., De Beni & Pazzaglia, 1995), such as general, specific and episodic, which have different implications for neurological structure and psychological functioning (Kosslyn, 1994). An image may be general referring to a concept without any reference to a particular example or to specific characteristics of the item (e.g., cube). On the other hand, one can have a specific image of a cube, such as Rubik's cube. Thus, a specific image refers to a single, well-defined example of the concept without reference to a specific episode. Lastly, an episodic-autobiographical image refers to the occurrence of a single episode at a particular time and place in the subject's life connected to the concept (e.g., building a cube using polydron material). In this paper, the term "image" refers to mental representations of a cognitive structure associated with a particular concept built up over the years through various experiences, which can be stored in both depictive and propositional format, and possess different functional characteristics (Kuzle & Glasnović Gracin, under review-b).

2.2. Developmental aspects of children's drawings

Developmental-stage theory based on the works from Rousseau to Froebel assumes that the stages occur in sequential order. Lucquet (1913, 1923, in Anning & Ring, 2004) classified five stages of drawing development in children:

- (1) scribbling stage (ages 2 to 4 years): scribbles are random and purposeless with children exploring art materials in a playful way. In addition, scribbles move from uncontrolled to progressively more controlled, and children discover meaning in their scribbles.
- (2) pre-schematic stage (ages 4 to 7 years): drawings become more complex with representative symbols for objects in the environment, such as circles, squares, and lines. The child has not yet developed a "schema". In addition, there is no awareness of the object organization, rather objects in drawings float in space.
- (3) schematic stage (ages 7 to 9 years): drawings are characterized by a schema, meaning adhering to the same symbol to represent a specific object (e.g., a child draws houses the same way every time). The term schema, thus, refers to the habitually repeated symbol for an object. In addition, drawings become more proportional and detailed.
- (4) visually unrealistic stage (ages 9 to 11 years): drawings are characterized by far more details (e.g., gender, clothing differences) and spatial perspective is evident. The child is still unable to create a realistic picture, but rather it contains visual contradictions.
- (5) visual realism stage (ages 11 to 13 years): drawings reflect an artwork in the manner of adult artists portraying the child's understanding of life. In other

words, the child has control with respect to medium, content, and organization. Self-critical and self-conscious aspect is an important characteristic of this stage.

These developmental stages are “a foundation for understanding children’s drawings in general” (Malchiodi, 1998, p. 98). Moreover, the developmental-stage theory provides a lens for research designs and for creating effective interventions (Anning & Ring, 2004; Malchiodi, 1998).

3. Visual research in mathematics education using drawings

When a young child draws they are offering us a window into their own developing understanding of the world and their relationships to significant people, things and places around them. Drawings provide rich insights into young children’s thinking and developing sense of self, including their gender roles. Drawings also provide children with a tool for telling themselves and us elaborate stories. (Anning & Ring, 2004, p. x)

Drawings as a visual method have been recognized as an alternative form of expression for (young) children. For instance, Barlow, Jolley, and Hallam (2011) reported that freehand drawings tend to facilitate the recalling of events that are unique, and interesting to students. Additionally, they can help students better recall and express more details about the events they depicted. For children, drawing is much more than a simple representation of what they see before them; rather it can be understood as one way in which they are making sense of their experiences (Anning & Ring, 2004). Lodge (2007), for instance, explored children’s drawings of learning in the primary grade classroom (6 to 7-year-olds). The results showed that even very young children have developed a wide range of ways to represent learning in the classroom, such as drawing the common perceptions of learning in classrooms (dependence on the teacher, individual and separate learning activities), and social relationships with their teacher. In that manner, drawings open a holistic way into children’s lived experiences, and their conceptions of mathematics and teaching (e.g., Einarsdóttir, 2007). Additionally, Kearney and Hyle (2004) found that using participant-produced drawings is more likely to accurately represent participants’ experiences and emotions. The participatory approach is characterized by establishing a rapport between the researcher and the participant as well as by a shift in power (im)balance in the researcher-participant relationship, with a less researcher-imposed structure. In other words, drawings function as a catalyst, helping participants to articulate their feelings, emotions, and lived experiences. In that manner, participant approach allows for depth of discussion, participant’s own shaping of agenda, and encourages collaborative meaning-making as well as reliable and trustworthy data (Kearney & Hyle, 2004).

In the last two decades, drawings have been successfully used to access students’ beliefs about mathematics and mathematicians (e.g., Halverscheid & Rolka, 2006; Picker & Berry, 2000; Rolka & Halverscheid, 2006, 2011), students’ attitudes towards mathematics (e.g., Dahlgren Johansson & Sumpter, 2011), the emotional

atmosphere in mathematics lessons (e.g., Laine & Ahtee, 2017; Laine, Näveri, Ahtee, Hannula, & Pehkonen, 2013; Laine et al., 2015; Tuohilampi, Laine, Hannula, & Varas, 2016), and students' conceptions of mathematics lessons (e.g., Ahtee et al., 2016; Kuzle & Glasnović Gracin, accepted; Pehkonen, Ahtee, Tikkanen, & Laine, 2011; Pehkonen et al., 2016; Walls, 2007). Only a few studies (Glasnović Gracin & Kuzle, 2018; Kuzle & Glasnović Gracin, under review-b; Kuzle, Glasnović Gracin, & Klunter, 2018; Pitta, 1998) focused on students' images of mathematical content, and mathematics teaching and learning. In the following sections, I outline some of the studies, and their main results with a special attention given to possibilities that drawings offered.

3.1. Beliefs and attitudes toward mathematics and mathematicians

Halverscheid und Rolka (2006), and Rolka and Halverscheid (2006, 2011) developed a design, in which drawings – supported by written data – were used as a means for investigating students' (grade 5, 9, and 11) beliefs about mathematics. The students were asked to express their views on mathematics on a sheet of paper, which were then analyzed using Ernest's (1989, 1991) framework (instrumentalist, Platonist, and problem-solving world view). The results showed that the students had mixed world views (Rolka & Halverscheid, 2011), however, an instrumentalist world view dominated. Rolka and Halverscheid (2011) also investigated the reliability of the method when determining Ernest's categories on the basis of drawings and texts. The inter-rater design showed a good degree of reliability, which led to a more detailed description of the characteristic features, and a classification scheme for assigning one of Ernest's categories to students' drawings.

Dahlgren Johansson and Sumpter (2010) investigated young students' (grade 2 and 5) conceptions about mathematics and mathematics education by using a combination of three methods, namely survey with Likert-scale, open-ended questions, and drawings. They reported that while grade 2 students had a positive attitude toward mathematics, grade 5 students mostly reported having a negative attitude toward mathematics. Interestingly, the drawings offered insight into the social aspects of a mathematics classroom. For instance, mathematics was illustrated as an individual activity, which with time was narrowed down to pure calculation. Similarly, Picker and Berry (2000) investigated lower secondary students' images of mathematicians in different cultural contexts (i.e., USA, UK, Finland, Sweden, Romania) by using drawings and a survey. The drawings have shown to be a valuable additional research tool to the survey, as they provided a rich insight into students' experiences in mathematics classes. In addition, Picker and Berry (2000) argued that student-produced drawings may foster a dialogue between the teachers and the students, especially with respect to challenging students' negative views about mathematics, and their stereotypes of mathematicians.

3.2. Emotional and social atmosphere in mathematics classroom

In their work, Laine et al. (2013), Laine et al. (2015), Laine and Ahtee (2017), and Tuohilampi et al. (2016) focused on the collective emotional atmosphere in grade

3 and grade 5 mathematics classroom, respectively. Both benefits and drawbacks of using drawings were reported in the studies. With respect to the former, the authors advocated for using drawings as a good and versatile method to collect data about the collective emotional atmosphere in mathematics lessons. In addition, they argued for using drawings as a teaching tool, which may allow teachers with a possibility to obtain and evaluate information on how their students experience mathematics and mathematics lessons. Nevertheless, some drawbacks occurred in the studies, especially with regard to the interpretation of students' drawings. Furthermore, the quality of drawings varied a lot taken that they worked with young students, and hence, their drawing skills varied. They concluded that it is necessary to investigate how the drawing skill level as well as improvement in drawing skills affect the results.

Pehkonen et al. (2011) and Ahtee et al. (2016) focused on the social aspect of the mathematics classroom. In the former study, the authors specifically looked at communication in the third-graders' drawings. They reported that typical communication in class seemed to be built mainly around three themes: mathematics is nice/easy, mathematics is dull/difficult, and students can do mathematics. In the latter study, the authors developed two inventories on the basis of the drawings' analysis. Two inventories contained teachers' and students' activities during a mathematics lesson as seen in the students' drawings. The first inventory contained 14 separate items organized into six groups that included diverse teacher activities (e.g., giving information on mathematics, giving feedback, asking questions), whereas students' activities were organized into five groups that included altogether 22 items (e.g., activities of a single student, student-student discussion on mathematics, student-teacher discussion on mathematics). In that manner, both inventories opened a window into students' perceptions of both their teacher's and their classmates' activities in mathematics lessons. From both research and practical perspective, the inventories gave an opportunity to provide insights into what is happening in classrooms, and how different aspects change over a period of time (Ahtee et al., 2016). Although drawings were a versatile way of collecting data in both studies, Ahtee et al. (2016) concluded that the students need to be as clear as possible told what they should draw in order to prevent a large variability among the drawings.

To summarize, drawings as a research method have made an alternative and complementary contribution to conventional research methods providing researchers with a less invasive method when working with young children (e.g., Einarsdóttir, 2007; Veale, 2005). They opened a nonverbal channel to children's images of mathematics, mathematics teaching and learning, and the mathematics classroom (e.g., teachers, peers, activities) (e.g., Ahtee et al., 2016; Dahlgren Johansson & Sumpter, 2011; Halverscheid & Rolka, 2006; Laine & Ahtee, 2017; Laine et al., 2013, 2015; Pehkonen et al., 2011, 2016; Rolka & Halverscheid, 2006, 2011; Tuohilampi et al., 2016). Thus, drawings contained in-depth and rich information from which one can select an aspect of interest, depending on its purpose. However, studies focusing on specific mathematical content, such as arithmetic and geometry, using drawings are limited. In the next section, I focus on my current

work focusing on the primary grade students' perceptions of geometry classroom learning milieu from a cognitive, social, and emotional perspective.

4. Drawings as external representations of children's mathematical fundamental ideas and socio-emotional atmosphere in mathematics lessons

According to mathematics standards (e.g., KMK, 2005; MZOS, 2006) one of the aims of teaching mathematics is to create a learning environment having an open, encouraging and positive atmosphere. The goal of the DrawMeEmma project ("*Drawings as external representations of children's mathematical fundamental ideas and socio-emotional atmosphere in mathematics lessons*") is to provide meaningful and in-depth insights into primary grade students' (grades 1-6) perceptions of mathematics classroom learning milieu from a cognitive, social, and emotional perspective. The underlying idea of the project is to develop a deeper understanding of the factors that may shape and influence students' understanding of mathematics, and their attitudes towards different mathematics areas (i.e., arithmetic, geometry), and argue for it as a socio-cultural construct embedded in and shaped by the students' learning environment in different cultures. By comparing how these constructs are lived in different contexts (i.e., different mathematics lessons) and cultures (i.e., Croatia, Germany,¹ Finland²), the goal is to identify not only the similarities and differences within and between cultures, but also to help deepen our understanding of what is meant by affective domain in mathematics education. These insights may also allow practical contributions by providing teachers with ideas for modifying their teaching practices reflecting a more open, encouraging atmosphere in different mathematics lessons. Methodologically, we employ a relatively new method of collecting young students' data, namely drawings, as an alternative form of expression, which is more appropriate for children (e.g., Hannula, 2007; Veale, 2005). Thus, students' drawings are taken as a research object with the goal of assessing the objectivity and the reliability of the method in the context of primary grade students' perceptions of mathematics classroom learning milieu from a cognitive, social, and emotional perspective.

For the purpose of the project, two instruments were developed. The first instrument is an adaptation of the instrument from the work of Halverscheid and Rolka (2006), and Rolka and Halverscheid (2006, 2011), which involved drawing an individual image of geometry. Here, each student was given a blank piece of A4-paper with the following assignment: "Imagine you are an artist. A good friend asks you what geometry is. Draw a picture in which you explain to him/her what geometry is for you. Be creative in your ideas." In addition, the students answered three questions, which were on the reverse side of the sheet:

- In what way is geometry present in your drawing?

¹ The PI in Croatia is colleague Dubravka Glasnović Gracin from the University of Zagreb.

² The PI in Finland is colleague Anu Laine from the University of Helsinki.

- Why did you choose these elements in your drawing? Why did you choose this kind of representation?
- Is there anything you did not draw, but still want to say about geometry?

The second instrument is an adaptation of the instrument from the work of Ahtee et al. (2016), Laine et al. (2013, 2015), and Pehkonen et al. (2016). Each student was given a blank piece of A4-paper with an assignment given by a fictional 12-years old bright girl by the name of Anna: “Dear _____, I am Anna and new to your class. I would like to get to know your class better. Draw two pictures of your mathematics lessons. The first drawing should show what your arithmetic lessons are like and how you view them. The second drawing should show what your geometry lessons are like and how you view them. Include in each drawing your teaching group, the teacher, and the pupils. Use speech bubbles and thought bubbles to describe conversation and thinking. Mark the pupil that represents you in the drawing by writing “ME”. Thank you and see you soon! Your Anna.”

In the project, the drawings were used as an entry to a semi-structured interview. Each child was asked to describe what he or she had drawn. This procedure gave each child the opportunity to frame their own experiences and interpret their drawing. This procedure also served as a guide for further questions. Multiple data sources were used to assess the consistency of the results, and to increase the validity of the instruments as was suggested by Einarsdóttir (2007).

This section is divided into four parts. The first part focuses on the evaluation of the distribution of fundamental ideas of primary grade students (grades 3-6) in the context of school geometry (Kuzle & Glasnović Gracin, under review-b; Kuzle, Glasnović Gracin, & Klunter, 2018). The second part focuses on grade 5 students’ perceptions of geometry classroom social learning milieu (Kuzle & Glasnović Gracin, accepted). The third part focuses on a case study, which explored students’ perceptions of the emotional atmosphere in geometry lessons on an individual level (Glasnović Gracin & Kuzle, 2018). In the last part, I focus on future work within the DrawMeEmma project using participant-produced drawings.

4.1. Drawings as external representations of children’s mathematical fundamental ideas in the context of school geometry

One of the trends counteracting the decrease in geometry in school mathematics focuses on the idea of structuring geometry curricula around *fundamental ideas* as a means of curriculum development (e.g., Mammana & Villani, 1998; Van de Walle & Lovin, 2006; Wittmann, 1999). This term can be interpreted in many different ways (e.g., Rezat, Hattermann, & Peter-Koop, 2014). For instance, Winter (1976) defined fundamental ideas as ideas that have strong references to reality and can be used to create different aspects and approaches to mathematics. In addition, fundamental ideas are characterized by a high degree of inner richness of relationships, and by gradual and continuous development in every grade (e.g., Rezat et al., 2014; Van de Walle & Lovin, 2006).

For school geometry, diverse models of fundamental ideas exist. For instance, Mammana and Villani (1998) suggested that school geometry be organized around

the following fundamental ideas: the idea of measurement, mapping, projection and topology, the idea of geometric figures, simple motions, and transformations, and the idea of connections to arithmetic. Principles and Standards for School Mathematics, on the other hand, provided a content framework for geometry organized around shapes and properties, transformation, location, and visualization (Van de Walle & Lovin, 2006). Similarly, Wittmann (1999) proposed that school geometry be organized around the following seven fundamental ideas: (1) geometric forms and their construction, (2) operations with forms, (3) coordinates, (4) measurement, (5) patterns, (6) forms in the environment, and (7) geometrization (see Table 1).

Table 1. Wittmann's fundamental ideas of geometry.

Fundamental idea	Description
Geometric forms and their construction	The structural framework of elementary geometric forms is three-dimensional space, which is populated by forms of different dimensions: 0-dimensional points, 1-dimensional lines, 2-dimensional shapes, and 3-dimensional solids. Geometric forms can be constructed or produced in a variety of ways (e.g., using drawing tools or manipulatives) through which their properties are imprinted.
Operations with forms	Geometric forms can be operated on; they can be shifted (e.g., translation, rotation, mirroring), reduced/increased, projected onto a plane, shear, compressed/extended in a certain direction, distorted, split into parts, combined with other figures and shapes to form more complex figures, and superimposed. In doing so, it is necessary to investigate spatial relationships and properties changed by each manipulation.
Coordinates	Coordinate systems can be introduced on lines, surfaces and in space to describe the location of geometric forms with the help of coordinates.
Measurement	Each geometric form can be qualitatively and quantitatively described. Given units of measure, length, (surface) area or volume of geometric forms as well as angles can be measured. In addition, angle calculation, formulae for perimeter, area and volume, and trigonometric formulas also deal with measurement.
Patterns	In geometry, there are many possibilities to relate points, lines, shapes, solids and their dimensions in such a way that geometric patterns emerge (e.g., frieze patterns).
Forms in the environment	Real-world objects, operations on and with them as well as relations between them can be described with the help of geometric forms.
Geometrization	Plane and spatial geometric facts, properties and problems, but also a plethora of relationships and abstract relationships between numbers (e.g., triangular numbers) can be translated into the language of geometry and described geometrically, and then translated again into practical solutions. Here, graph theory and descriptive geometry (central perspective, parallel projection) play an important role.

For the study focused on children's mathematical fundamental ideas in the context of school geometry (Kuzle & Glasnović Gracin, under review-b; Kuzle, Glasnović Gracin, & Klunter, 2018), an explorative qualitative research design with 114 primary grade students (grades 3-6) from the federal state of Brandenburg (Germany) was conducted. This age group was optimal for the purposes of the study as this is an important period for the development of geometric thinking (Mammana & Villani, 1998). The division was the following: 25 3rd grade, 33 4th grade, 28 5th grade, and 28 6th grade students. The main goal of the inquiry was (1) to develop an inventory that would provide insight into students' images of geometry from the perspective of fundamental ideas of geometry, and (2) to obtain an instantaneous picture of actual educational classroom practices in geometry teaching by using participant-produced drawings on the basis of the developed inventory (1).

Figure 1 illustrates the coding: F1 refers to the fundamental idea of geometric forms and their construction, while F6 refers to the fundamental idea of forms in the environment. With respect to the latter (F6), each real-world object was coded as a whole, whilst each 1- and 2-dimensional figure with respect to the former (F1). The number in brackets gives the absolute frequency of the category and the subcategory (Kuzle & Glasnović Gracin, under review-b).

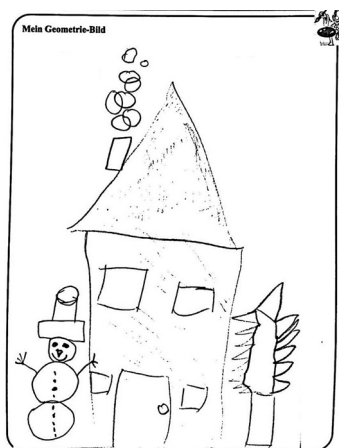

The child drew three real-world objects, namely a house, a snowman, and a tree, consisting of different geometric forms.

Coding:

F1a: point

F1b: curved line segment,
straight line segment

F1c: circle, square, rectangle, triangle

F6: snowman, house, tree

Summary of the coding:

F1(7): F1a(1), F1b(2), F1c(4)

F6(3)

Figure 1. Grade 3 student's image of geometry with codes.

Table 2 illustrates the distribution of fundamental ideas of primary grade students on the basis of participant-produced drawings. From the table, it is evident that the fundamental idea of geometric forms and their construction (F1) was the most frequently coded fundamental idea of geometry (73.8 %), which was independent of the grade level. Nevertheless, the drawings varied, and there were some patterns in the students' answers pertaining to different aspects of this fundamental idea. In all grades, different plane surfaces dominated in the drawings, ranging from 41 % in both grades 5 and 6, to 59.1 % and 55.8 % in grades 4 and 3, respectively (see Figures 2a and 2b). This aspect was mentioned by the most children: 89 out of 114 children gave answers pertaining to 2-dimensional figures.

Table 2. Absolute and relative frequencies of students' fundamental ideas of geometry.

Grade	Absolute and relative frequencies of fundamental ideas						
	F1	F2	F3	F4	F5	F6	F7
3	110 (73.3 %)	13 (8.7 %)	12 (8 %)	2 (1.3 %)	2 (1.3 %)	11 (7.3 %)	0 (0 %)
4	224 (77.8 %)	13 (4.5 %)	3 (1.0 %)	13 (4.5 %)	2 (0.7 %)	31 (10.8 %)	2 (0.7 %)
5	174 (67.7 %)	16 (8.2 %)	2 (1.0 %)	10 (5.1 %)	2 (1.0 %)	31 (16.4 %)	1 (0.5 %)
6	181 (74.2 %)	9 (3.7 %)	2 (0.8 %)	29 (11.9 %)	1 (0.4 %)	15 (6.2 %)	7 (2.9 %)
Total	647 (73.8 %)	51 (5.4 %)	19 (2.2 %)	54 (6.2 %)	7 (0.8 %)	89 (10.2 %)	10 (1.1 %)

The second most often depicted aspect were solids, which were mentioned by almost every second child (see Figures 2a and 2b). This aspect was most often seen in grade 4 students' drawings. In all other grades, the range was between 15.9 % (grade 5) and 26.4 % (grade 3). Various drawing tools (e.g., drawing stencil, ruler, protractor, compass) were the third most frequently coded aspect ranging from 6.4 % in grade 3 to 17.1 % in grade 6 (see Figure 2b). This aspect was mentioned by almost every second child. Most notably students differed with respect to the properties of geometric forms mentioned. This aspect was only seen in grade 4-6 students' drawings, where every fifth, fourth, and third child, respectively, mentioned this aspect. From another perspective, this aspect was coded in 3.1 % (grade 4) and in grade 5 in 24.5 % of cases. Thus, properties of geometric forms gain in importance as primary grade students progress into higher grades. Starting with grade 4, the angle concept was present in the drawings in a figurative manner. While grade 4 and 5 students drew a right angle, grade 6 students mostly drew an arbitrary angle. The aspects pertaining to 0-dimensional objects and composite figures were mentioned by the fewest children.

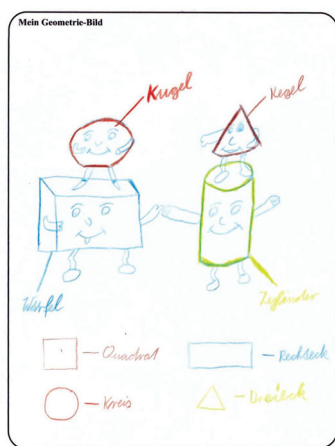

Figure 2a. Grade 4 student's drawing with 2- and 3-dimensional figures (3D solids: sphere, cone, cube, cylinder; 2D shapes: square, rectangle, circle, triangle).

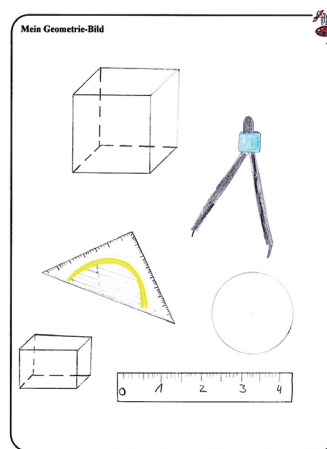

Figure 2b. Grade 6 student's drawing with 2- and 3-dimensional figures, drawing tools, and of two rectangular prisms.

The fundamental idea of forms in the environment (F6) was the second most frequently coded fundamental idea of geometry (10.2 %). The students' drawings pertaining to this fundamental idea showed an increase from grade 3 to grade 5 (from 7.3 % to 16.4 %), but a decrease in grade 6 (6.2 %). Something pertaining to F6 was drawn by every fourth grade 3 student, every second grade 5 student, and every fifth grade 6 student. The children were very creative, drawing motifs, such as snowman, tree, house, robot, car, disco ball, tower, and tent (see Figures 1 and 3b).

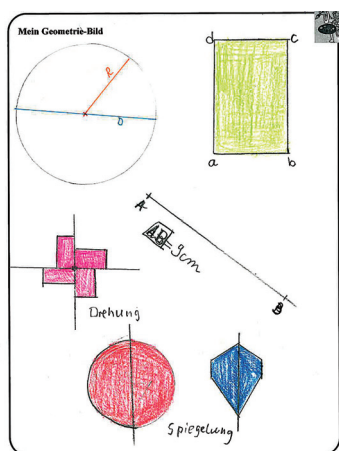

Figure 3a. Grade 4 student's drawing of figures with rotational ("Drehung") and line symmetry ("Spiegelung"), and segment length.

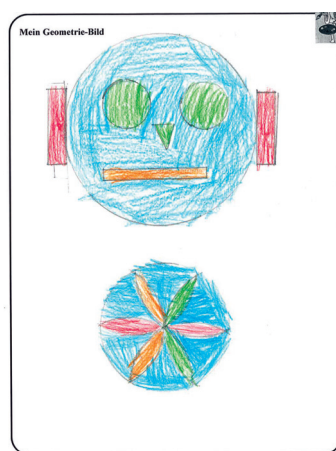

Figure 3b. Grade 3 student's drawing of a robot head and a seed of life pattern.

The fundamental idea of measurement (F4) was the third most frequently coded fundamental idea of geometry (6.2 %). The students' drawings showed an understanding of qualitative and quantitative attributes assigned to geometric forms at a progressive rate (i.e., 1.3 % in the lower grades to 11.9 % in the higher grades). In grade 3 only the length of segments was addressed, and by two children only. In grade 4, the length of segments (77 %) (see Figure 3a), and angle measurement were illustrated. In grade 5, in addition to length (50 %), two measures, namely perimeter (10 %) and area were illustrated. Lastly, grade 6 students' drawings depicted all five different measurement aspects, namely length, perimeter, surface area, volume, and angle measurement. The latter was mentioned by most children and was dominant in the drawings with 44 %. Different measuring tools were also present in the students' drawings. For instance, in earlier grades a ruler and a protractor were mentioned as tools for measuring lengths. In grade 6, however, the protractor was assigned another role, namely as a tool to measure angles. The perimeter was the least coded aspect. The aspects pertaining to estimation, conversion of measuring units, and scaling were not present in any drawing.

The fundamental idea of operations with forms (F2) was the fourth most frequently coded fundamental idea of geometry (5.4 %). The students' drawings did not reflect a linear increase from grades 3-6, as this fundamental idea was most

frequently coded in grade 3 and least coded in grade 6 students' drawings. Interestingly, about 24 % of the grade 3 and 4 students, compared to 39 % in grade 5 and only 25 % in grade 6, drew an aspect attributed to this fundamental idea. For instance, the fundamental idea of folding and unfolding was mentioned by almost every seventh child, while line symmetry was mentioned by almost every 11th child (see Figure 3a). Line symmetry was especially dominant in grade 3 drawings (69.2 %). Furthermore, this was the only operation that was mentioned in all of the grades. Operations, such as translation, dilation, and (de)composition were only present in grade 4, point reflection in grade 5, and tessellation in grade 5 drawings only.

The fundamental ideas of coordinates, (F3), geometrization (F7), and patterns (F5) were the three least coded fundamental ideas with 2.2 %, 1.1 %, and 0.8 %, respectively. With respect to the fundamental idea of coordinates (F3), a rapid decrease from the lower (8 % in grade 3) to the higher grades was observable (0.8 % in grade 6). Additionally, the drawings qualitatively differed. Lower grade students used prepositions (e.g., right, left, below) to describe the position of geometric forms, while upper grade students used a coordinate system for it. With respect to the fundamental idea of geometrization (F7), a small number of instances pertaining to this fundamental idea was illustrated by the students, which may be due to the abstract nature of this fundamental idea. However, an increase from the lower to higher grades was evident, reaching a maximum of 2.9 % in grade 6 as well as the versatility of this fundamental idea's aspects. For instance, the drawings of grade 6 students showed three different aspects: geometrical facts (i.e., the sum of interior angles of a triangle, Euler's line, triangle congruence theorems), parallel projection of a cube and a rectangular prism (see Figure 2b), and geometrical problems (concerning angle measurements). With respect to the fundamental idea of patterns (F5), the students' drawings made it evident, that very few students think of geometric patterns when thinking about geometry. Apart from grade 5, where two students' drawings illustrated some patterns, only one student per grade level depicted this aspect of geometry. In these instances, different patterns were drawn, such as simple patterns using basic geometric forms, frieze patterns, and the seed of life pattern (see Figure 3b).

To summarize, independent of the grade level, the fundamental idea of geometric forms and their construction (F1) dominated in the students' drawings. Moreover, there was no observable increase in knowledge from grade 3 to grade 6, even though one might expect a more comprehensive picture from grade 6 students than appeared in the data. Interestingly, students associated geometry more with forms in the environment (F6), than with measurement (F4) (see Table 2), which dominates throughout the curriculum (RLP, 2015). The fundamental idea of coordinates (F3) was not frequently found in the student's drawings, even though this topic and its different aspects are relevant from early grades on (RLP, 2015). With respect to the fundamental idea of measurement (F4), an increase at every grade level was observable, with grade 6 students' drawing portraying its diverse aspects. The low results with respect to the fundamental idea of patterns (F5) suggest that this content is either rarely discussed (Backe-Neuwald, 2000) or does not seem to be directly linked to geometry lessons, but rather to algebra lessons. Additionally,

the results with respect to the fundamental idea of geometrization were extremely low. With respect to versatility of different fundamental ideas, the majority of the students drew aspects pertaining to either one or two fundamental ideas. Only rarely did students' drawings and interviews present an image containing three or four fundamental ideas of geometry, mostly evident in the drawings of grade 5 and 6 students. Taking also into account that the fundamental idea of geometric forms and their construction was the most frequently depicted fundamental idea in the students' drawings independent of the grade level, one could conclude that the study participants had a rather narrow view of geometry.

4.2. Drawings as external representations of children's perceptions of classroom social climate in the context of school geometry

Classroom is a social context for learning, which with time develops a distinct social climate as it is a function of its different factors, such as norms and rules, student task-related interaction, styles of leadership, and composition of the group members (e.g., Moos & Moos, 1978; Trickett & Moos, 1973). The classroom social climate refers to shared subjective representation of important characteristics of the classroom as a learning environment involving the physical environment of the classroom, the social relations between teachers and students or students among each other, expectations with regard to performance and behavior, the way in which teaching and learning processes take place, and the specific norms and values in the classroom (Eder, 2002). According to Bülter and Meyer (2015) and Gruehn (2000), the climate-creating determinants help the teacher to create a working alliance with the students, and thus, to achieve positive effects with regard to each student's self-confidence, social behavior, performance, and attitude toward school. In contrast, a negative classroom climate may lead to social and emotional behavioral disturbances, and thus, have a negative impact on students' performance (Evans, Harvey, Buckley, & Yan, 2009). Thus, classroom climate influences students' growth, and their academic, social and emotional development (Evans et al., 2009). Kuzle and Glasnović Gracin (accepted) propose a possible further development of existing classroom social climate models (e.g., Eder, 2002; Evans et al., 2009; Fraser, 1989, 1998; Trickett & Moos, 1973) to better understand structure, functions, and processes in a mathematics classroom. In their model, classroom social climate is conceptualized as a function of three conceptual categories, namely *Interpersonal Relationship*, *Personal Growth*, and *Order*, that are described on the basis of its dimensions, subdimensions, and scales:

- *Interpersonal Relationship* refers to nature, the intensity of personal relationships, and the mutual influences of the teacher and the students within the classroom, including social, pedagogical and mathematical aspects. The Verbal and non-verbal communication of the teacher (i.e., teacher's position in the classroom, support by the teacher), Verbal and non-verbal communication of the students (i.e., students' position in the classroom, participation, affiliation) and Organization (i.e., working method, classroom seating arrangement) are conceptualized as relationship dimensions.

- *Personal Growth* refers to the goal orientation and clarity of the lesson objective. On the one side, a lesson goal can be clearly represented by mathematical content or an assignment on the backboard, the teacher identifying the goal of the lesson or students working on their assignment. On the other side, the lesson objective can be pursued by using different teaching materials specific to geometry (e.g., geometric forms, models, tools), which can be utilized by class protagonists (teacher, students).
- *Order* refers to the social norms and maintenance of order in the classroom. Since social norms are shared principles of behavior that are considered acceptable in a group, not only the teacher, but also the students are responsible for proper conduct, keeping order, and behaving properly.

For the study focused on children's perceptions of the classroom social climate in the context of school geometry (Kuzle & Glasnović Gracin, accepted), an explorative qualitative research design with 114 students (grades 3-6) from several urban schools in the federal state of Brandenburg (Germany) was conducted. The main goal of the inquiry was (1) to develop an inventory that would provide insight into students' perceptions of the classroom social climate and (2) to obtain an instantaneous picture of classroom social climate in the context of school geometry by using participant-produced drawings on the basis of the developed inventory (1). Here, I report on the results of 30 grade 5 students' drawing of geometry classroom (Kuzle & Glasnović Gracin, accepted). This age group was optimal for the purposes of the study as the quality of drawings was high.

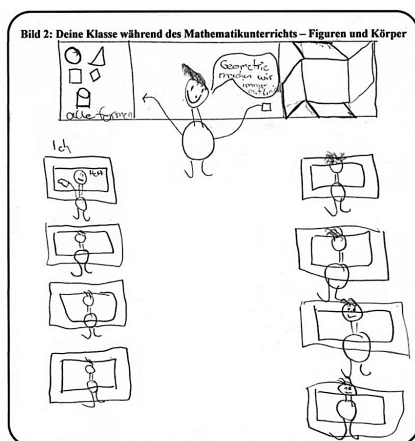

Figure 4. Grade 5 student's drawing of a geometry classroom.

Table 3 illustrates the coding with accompanying codes (e.g., D = dimension, letters A to C = subdimensions, ordinal numbers = subscales, T = teacher, S = student) of Figure 4. The number in brackets gives the number of drawn persons who fall into this category.

Table 3. An example of coding of one grade 5 student's drawing of a geometry classroom.

Coding	Explanation
1. Category "Interpersonal Relationship"	
D1A.1.L Position in the classroom	The teacher is standing in front of the blackboard.
D1A.11.L Support by the teacher	The teacher makes a mathematical statement: "Geometry is always done with a ruler".
D1B.2.S(8) Position in the classroom	The students sit at the table.
D1B.11.S(8) Participation	The students listen to the teacher explain something.
D1B.29.S Affiliation	The affiliation is not identifiable.
D1C.1 Working method	The teacher stands in front of the class and explains something. The lesson is taught frontally.
D1C.7 Seating arrangement	The tables are frontal, arranged in four rows and two columns.
2. Category "Personal Growth"	
D2.A1 Orientation	There is mathematical content on the blackboard (shapes, bodies and net of a cube).
D2.B1 Teaching material	2D-forms are represented (i.e., circle, triangle, square, rhombus).
D2.B2 Teaching material	3D-forms are represented (i.e., a cylinder).
D2.B3 Teaching material	2D-models are displayed. The representation on the right of the blackboard indicates a cube net, which unfolds.
3. Category "Order"	
D3A.3 Keeping order	The teacher and the students do not show any behavioral demands.

The analysis of the students' perceptions of geometry classroom learning milieu showed that all conceptual categories and respective dimensions of the classroom social climate model of Kuzle and Glasnović Gracin (accepted) were present in the students' drawings, with mainly positive indicators of classroom social climate drawn. Thus, their model of classroom social climate was theoretically coherent, and consistent with the data generated in the context of grade 5 geometry. In Table 4, the distribution of classroom social climate aspects as illustrated in grade 5 students' drawings is presented.

Table 4. Absolute and relative frequencies of students' perceptions of classroom social climate in the context of grade 5 geometry.

Category	Dimension	Subdimensions		
		Scales	Absolute frequency	Relative frequency
Interpersonal relationship	Verbal and non-verbal communication of the teacher	Teacher's position in the classroom		
		In front of the blackboard	21	70 %
		Among students	3	10 %
		At the desk	4	13.3 %
		Somewhere in the classroom	0	0 %
		Unidentifiable	0	0 %
		Unavailable	2	6.7 %
		Support by the teacher		
		Assistance	5	16.7 %
		Positive feedback	0	0 %
		Negative feedback	0	0 %
		Mathematics related question	5	16.7 %
		Mathematics related statement	8	26.7 %
		Observation	0	0 %
		Non-mathematical comment	1	3.3 %
		Passive	0	0 %
	Unidentifiable/Unavailable	15	50 %	
	Verbal and non-verbal communication of the students	Students' position in the classroom		
		Only one or two students shown (at the blackboard / at the table)	6	20 %
		At the table	17	56.7 %
		Next to the teacher	1	3.3 %
		In front of the blackboard	2	6.7 %
		Amongst other students	0	0 %
		Somewhere in the classroom	2	6.7 %
		Unidentifiable	3	10 %
		Unavailable	3	10 %
		Participation		
		Working on assignments at the table	8	26.7 %
		Working on the assignment on the blackboard	5	16.7 %
		Listening	3	10 %
		Responding	2	6.7 %
		Questioning	0	0 %
Asking for assistance		0	0 %	
Review	2	6.7 %		
Discussion	2	6.7 %		
Positive expression	3	10 %		

		Negative expression	0	0 %		
		Non-mathematical comment	9	30 %		
		Passive	1	3.3 %		
		Unidentifiable	4	13.3 %		
		Unavailable	6	20 %		
		Affiliation				
		No communication with other students (while working on the assignments)	7	23.3 %		
		Student-student communication	2	6.7 %		
		Student-student encouragement	0	0 %		
		Student-student help request	0	0 %		
		Student-student support	1	3.3 %		
		Negative comments toward other students	2	6.7 %		
		Unidentifiable/Unavailable	18	60 %		
		Organization	Working method			
	Teacher-centered instruction		15	50 %		
	Individual work		4	13.3 %		
	Group work		1	3.3 %		
	Working with a partner		0	0 %		
	Work/discussion while sitting in a (half-)circle		2	6.7 %		
	Unidentifiable/Unavailable		8	26.7 %		
	Classroom seating arrangement					
	Traditional classroom arrangement		13	43.3 %		
	U-shaped arrangement		1	3.3 %		
	Mixed arrangement		3	10 %		
	(Half-)circle arrangements		1	3.3 %		
	Group tables		3	10 %		
	Unidentifiable	6	20 %			
Unavailable	3	10 %				
Personal growth	Goal orientation	Lesson goal	28	93.3 %		
		Mathematical content	2	6.7 %		
		Teacher shows mathematical content	10	33.3 %		
		Alignment of lesson goal and student activity	13	43.3 %		
	Teaching material	2D-shapes	20	66.7 %		
		3D-shapes	8	26.6 %		
		2D-models	2	6.7 %		
		3D-models	5	16.7 %		
		Poster	1	3.3 %		
		Geometric tools (teacher)	3	10 %		
		Geometric tools (students)	1	3.3 %		
		Unavailable	2	6.7 %		
	Order	Keeping order	Led by the students	3	10 %	
Led by the teacher			2	6.7 %		
Unavailable			26	86.7 %		

As can be seen in Table 4, the students' drawings revealed that overall organization of the assignments and the classroom reflects a rather traditional mathematics classroom with domination of frontal teaching (50 %) and traditional classroom seating arrangement (43.3 %). The teacher stood in front of the classroom in 70 % of the drawings, whereas the students sat at their tables in 56.7 % of the drawings. Additionally, the drawings revealed a broad spectrum of *Participation* in geometry lessons; while 43.4 % of the students worked on the assignment at the table or blackboard and 6.7 % of the students participated in the discussion of the tasks, almost a third of the students (30 %) did not follow any mathematical thoughts. These divergent results do not allow any conclusive statements as none of the scales from the *Participation* subdimension clearly dominated.

In 93.3 % of the drawings, the goal of the lesson was clearly identified from the students' perspective (e.g., mathematical assignments were illustrated on the blackboard). Moreover, the lesson goal and student activity were aligned in 43.3 % of the drawings. To reach the lesson goal(s), different *Teaching materials* were drawn, such as 2D-shapes (66.7 %), 3D-solids (26.6 %), and 3D-models (16.7 %). Also, in 10 % of the drawings the teachers were illustrated working with geometric tools. These elements indicate that in geometry lessons a specific teaching goal is being pursued, which may guide the students in the direction of increased performance, and the formation of interest in the subject (Evans et al., 2009; Gruehn, 2000).

In 86.7 % of the drawings, the behavioral demands on the part of the students and teachers (86.7 %) in the category *Order* were not illustrated. Only a small percentage (16.7 %) of behavioral demands on the part of both teachers and students were illustrated by the students. A higher percentage of such cues would be an indication that social behavior or discipline is insufficient, and thus, would represent a negative teaching climate (Evans et al., 2009). This indicates that the geometry lessons are well-designed with good teaching discipline and social behavior of the students (Bülter & Meyer, 2015).

As illustrated in Table 4, the absolute frequencies of "unavailable" and "unidentifiable" codes of some scales were high. This may indicate that some students had difficulties drawing or some aspects were difficult to draw, and the necessity to improve the semi-structured interview guide. Especially the latter is of importance with respect to gaining an in-depth insight into students' perceptions of psychosocial classroom learning milieu in the context of school geometry.

4.3. Drawings as external representations of children's perceptions of emotional atmosphere in the context of school geometry

In the last few decades, there has been an increasing interest in research on affect, such as the role of affect in learning and in the social context of the classroom, and the role of emotions in mathematical thinking (e.g., Hannula, 2011; Philipp, 2007). On the basis of a lengthy review of theories and findings in the area of affect, Hannula (2007) suggested a new framework, which can be interpreted as a

metatheoretical foundation for research in mathematics-related affect. The framework is described as a function of three dimensions: (1) cognitive, motivational and emotional aspects of the affect, (2) rapidly changing affective states vs. relatively stable affective traits, and (3) the social, the psychological and the physiological nature of affect (Hannula, 2007, p. 43). (1) The cognitive aspect of the affect refers to “knowledge, beliefs and memories” (Hannula, 2007, p. 43). The emotional aspect of the affect refers to “emotions belong joy, pride, sadness, frustration, anxiety and other feelings, moods and emotional reactions” (Hannula, 2007, p. 43). The motivational aspect of the affect refers to “personal preferences and explains choices” (Hannula, 2007, p. 43). From here on, I focus only on the emotional aspect of the affect with respect to (2) and (3).

Philipp (2007) defined emotions as “feelings or states of consciousness, distinguished from cognition. Emotions change more rapidly and are felt more intensely than attitudes and beliefs” (p. 259). They may be either positive (e.g., feeling of joy) or negative (e.g., feeling of panic). According to Hannula (2011), emotional atmosphere in the classroom can be regarded from a psychological and social point of view (see Table 5). The *psychological dimension* refers to the level of an individual and involves affective conditions (emotions, thoughts, meanings, and goals), and affective properties (attitudes, beliefs, values, and motivational orientations). The *social dimension* refers to the classroom community. Its affective conditions refer to social interaction, communication and the atmosphere in a classroom, while affective properties refer to norms, social structures and the atmosphere in the classroom. With respect to both dimensions, one can distinguish between two temporal aspects of affect, namely state and traits. *State* (affective condition) refers to the emotional atmosphere at a specific moment in the classroom, such as different emotions and emotional reactions (e.g., fear and joy), thoughts (e.g., “This is difficult.”), meanings (e.g., “I could do it.”), and aims (e.g., “I want to solve this task.”) (Laine et al., 2013). *Trait* (affective property) refers to more stable conditions or properties, such as attitudes (e.g., “I like maths.”), beliefs (e.g., “Maths is difficult.”), values (e.g., “Maths is important.”), and motivational orientations (e.g., “I want to understand.”) (Laine et al., 2013, 2015).

Table 5. Dimensions of the emotional atmosphere in a classroom.

	Psychological dimension or the level of the individual	Social dimension or the level of the community (classroom)
Affective condition (state)	Emotions and emotional reactions Thoughts Meanings Goals	Social interaction Communication Atmosphere in the classroom (momentarily)
Affective property (trait)	Attitudes Beliefs Values Motivational orientations	Norms Social structures Atmosphere in the classroom

For the study focused on children’s perceptions of the emotional atmosphere in the context of school geometry (Glasnović Gracin & Kuzle, 2018), a multiple case study with four high-achieving students from grades 2 to 5 from the Zagreb area (Croatia) was conducted. The main goal of the inquiry was to describe what

kind of emotional atmosphere in geometry lessons can be seen in primary grade students' drawings.

The drawings were analyzed with respect to facial features, body language, and thought features as suggested by Zambo (2006) (see Table 6). Afterward, the holistic evaluation of the emotional atmosphere in a classroom was based on five categories: positive (i.e., persons smile, think or behave positively, although some of the expressions can be neutral), ambivalent (i.e., there are both positive and negative facial/body language expressions or thoughts in the drawing), negative (i.e., persons are sad or angry or think/behave negatively, although some of the expressions can be neutral), neutral (i.e., all facial/body language expressions or other thoughts are neutral), and unidentifiable (i.e., no facial/ body language expressions or thoughts are present in the drawing) (Laine et al., 2013, 2015).

Table 6. Coding features for the evaluation of the emotional atmosphere in a classroom.

Feature and thoughts	Nature	Clues
Physical face features		
eyes	positive	Wide open
eyebrows	positive	Upward slant, open with interest, have a sparkle to them
mouth	positive	Full smile
eyes	neutral	Typical with no expression
eyebrows	neutral	No slant
mouth	neutral	Drawn as a straight line
eyes	negative	Downward slant
eyebrows	negative	Closed, slanted down
mouth	negative	Portrays a frown, open in a scream, drawn as a jagged line
Symbols drawn on face	negative	Tears, tongue stuck out, teeth in a growl
Physical body features		
arms	positive	Arms in the air, open arms
arms	neutral	Arms on the table
arms	negative	Crossed arms
Thoughts		
Symbols, signs, words, emotional words	positive	Hearts, peace signs, thumbs up, "easy", "fun", "I like"
Symbols, signs, words	neutral	No expression
Symbols, signs, words, emotional words	negative	Dark scribbles, sad, "bla, bla", "hate", "too hard"

Figure 5 illustrates one student's drawing of the geometry classroom. The teacher has a smiling facial expression. The drawer ("JA") has a smiling facial

of the individual could be described as positive (see Figure 6a), unidentifiable (see Figure 6b) or ambivalent (see Figure 5), but in no case dominantly negative. These findings are in line with the results presented in Laine et al. (2013, 2015). In two cases, facial expressions and speech bubbles helped interpret the student drawings, which were confirmed in the semi-structured interview.

In the presented study (Glasnović Gracin & Kuzle, 2018), a small sample with four above-average students was used, so the results are neither representative of a large population, nor are they generalizable. This limitation suggests a possible next step in the research: to conduct a study with a much larger sample with students of different levels of mathematical performance in order to obtain a broader picture of students' perceptions of the emotional atmosphere in geometry lessons. In addition, this would allow further development of an inventory for the analysis of students' perceptions of the emotional atmosphere in mathematics lessons.

4.4. Future work

The DrawMeEmma project is embedded in a mix-method paradigm focusing on children's perceptions of mathematics classroom learning milieu from a cognitive, social and emotional perspective in different countries as shown below (see Figure 7). The vertical design allows researching intra-individual relationships of primary grade students' fundamental idea and socio-emotional aspects in the mathematics classroom with respect to teachers' activities within each country. Hence, this allows looking at the consistency within each country. The horizontal design allows researching inter-cultural differences between primary grade students' fundamental idea and socio-emotional aspects in the mathematics classroom and teachers' activities between both countries (i.e., dialogue between countries with respect to both teachers' actions on the one side, and children's fundamental idea and socio-emotional aspects on the other side).

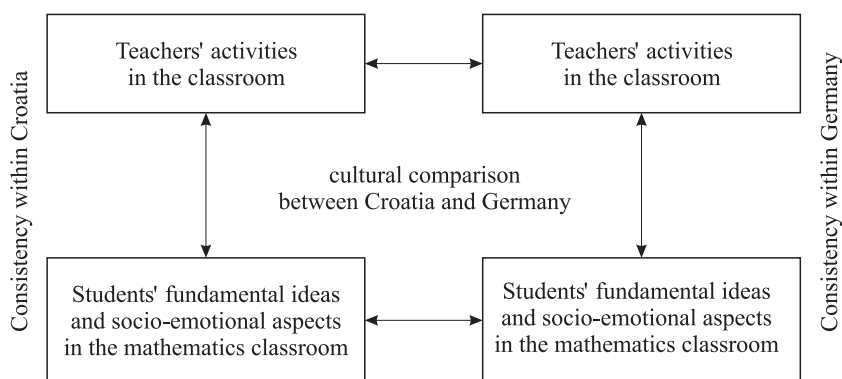

Figure 7. Comparative design between Croatia and Germany.

As such, the project focuses on the cultural comparison on the level of teachers, consistency between the level of teachers and primary grade students, cultural comparison on the level of primary grade students, and lastly on interrelations

between variables shaping the results. The results should, therefore, contribute to the intercultural validity of affective domain factors (i.e., cognition, emotional atmosphere, social dimension), and model of individual educational processes and their cultural-societal influenced determinants for both countries.

5. Conclusions

In mathematics education research, drawings and the processes by which they are made opened a new way of gaining insight into students' beliefs about mathematics and mathematicians (e.g., Halverscheid & Rolka, 2006; Picker & Berry, 2000; Rolka & Halverscheid, 2006, 2011), attitudes towards mathematics (e.g., Dahlgren Johansson & Sumpter, 2011), the emotional atmosphere in mathematics lessons (e.g., Glasnović Gracin & Kuzle, 2018; Laine & Ahtee, 2017; Laine et al., 2013, 2015; Tuohilampi et al., 2016), students' conceptions of mathematics lessons with respect to social and communicative aspects (e.g., Ahtee et al., 2016; Glasnović Gracin & Kuzle, 2018; Kuzle & Glasnović Gracin, accepted; Pehkonen et al., 2011, 2016), and images of mathematical content, and mathematics teaching and learning (Glasnović Gracin & Kuzle, 2018; Kuzle & Glasnović Gracin, under review-b; Kuzle, Glasnović Gracin, & Klunter, 2018; Pitta, 1998).

On the basis of the data from participant-produced drawings within the DrawMeEmma project (Glasnović Gracin & Kuzle, 2018; Kuzle & Glasnović Gracin, accepted, under review-b; Kuzle, Glasnović Gracin, & Klunter, 2018), three inventories were developed. These were then used as a window into students' perceptions of geometry classroom learning milieu from a cognitive, social, and emotional perspective. In that manner, we were able to obtain a first glimpse of actual educational classroom practices in geometry lessons. Naturally, as every research method, using drawing has shown drawbacks: some children had difficulties drawing, some did not like to draw, some drew objects which they found easy to illustrate, and some aspects could be expressed by drawing in a limited way (e.g., Kuzle & Glasnović Gracin, accepted, under review-b; Kuzle, Glasnović Gracin, & Klunter, 2018). In such cases, additional data sources (e.g., written questions, a semi-structured interview) are necessary (e.g., Dahlgren Johansson & Sumpter, 2011; Kuzle, Glasnović Gracin, & Klunter, 2018; Rolka & Halverscheid, 2006, 2011). In addition, interpretation of students' drawings has proven to be a challenging task. As Blumer (1969) noted, the analysis of drawings is understood as interpreting the meanings that the students had given to the situations and objects they had presented. Thus, in order to avoid the coder's own interpretation, not only analyst triangulation is needed, but also methodologies, such as participant-produced drawings (Kearney & Hyle, 2004), allowing each child to interpret his or her own drawing, which consequently allows an in-depth understanding of what the child had drawn.

In 1997, Anning suggested that drawing is underused and could be better developed in schools. Not only researchers can benefit from drawings as an alternative research method when working with (young) children, but also practitioners have the possibility of gaining insight into students' perceptions of mathematics

learning environment from diverse perspectives. Children's drawings and their interpretations of drawings are productive ways of promoting dialogue about teaching and learning between students and their teachers (Anning, 1997). Speaking for everyone involved in the DrawMeEmma project, we hope that with the help of the developed inventories a window into classroom's different aspects will be opened as well as many productive dialogues between teachers and their students.

References

- [1] AHTEE, M., PEHKONEN, E., LAINE, A., NÄVERI, L., HANNULA, M. S., & TIKKANEN, P. (2016). Developing a method to determine teachers' and pupils' activities during a mathematics lesson. *Teaching Mathematics and Computer Science*, 14(1), 25–43.
- [2] ANNING, A. (1997). Drawing out ideas: Graphicacy and young children. *International Journal of Technology and Design Education*, 7, 219–239.
- [3] ANNING, A., & RING, K. (2004). *Making sense of children's drawings*. Maidenhead, Great Britain: Open University Press.
- [4] BACKE-NEUWALD, D. (2000). *Bedeutsame Geometrie in der Grundschule: Aus Sicht der Lehrerinnen und Lehrer, des Faches, des Bildungsauftrages und des Kindes* [Significant geometry in primary school: From the viewpoint of the teachers, the subject, the educational mission, and the child] (Unpublished doctoral dissertation). Paderborn, Universität Paderborn.
- [5] BARLOW, C. M., JOLLEY, R. P., & HALLAM, J. L. (2011). Drawings as memory aids: optimising the drawing method to facilitate young children's recall. *Applied Cognitive Psychology*, 25(3), 480–487. doi:10.1002/acp.1716
- [6] BLUMER, H. (1969). *Symbolic interactionism. Perspective and method*. Englewood Cliffs, NJ: Prentice Hall.
- [7] BÜLTER, H., & MEYER, H. (2015). Unterrichtsklima als Determinante des Lernerfolg [Classroom climate as a determinant of learning success]. In I. Leitz (Ed.), *Motivation durch Beziehung* (pp. 25–67). Wiesbaden, Germany: Springer.
- [8] DAHLGREN JOHANSSON, A., & SUMPTER, L. (2010). Children's conceptions about mathematics and mathematics education. In K. Kislenko (Ed.), *Proceedings of the MAVI-16 conference* (pp. 77–88). Tallinn University of Applied Sciences, Estonia.
- [9] DE BENI, R., & PAZZAGLIA, F. (1995). Memory for different kinds of mental images: Role of contextual and autobiographic variables. *Neuropsychologia*, 33, 1359–1371.
- [10] EDER, F. (2002). Unterrichtsklima und Unterrichtsqualität [Classroom climate and teaching quality]. *Unterrichtswissenschaft: Zeitschrift für Lernforschung*, 30(3), 213–229.
- [11] EINARSDÓTTIR, J. (2007). Research with children: methodological and ethical challenges. *European Early Childhood Education Research Journal*, 15(2), 197–211.
- [12] ERNEST, P. (1989). The knowledge, beliefs and attitudes of the mathematics teacher: a model. *Journal of Education for Teaching*, 15(1), 13–33.
- [13] ERNEST, P. (1991). *The philosophy of mathematics education*. Hampshire, Great Britain: Falmer Press.

- [14] EVANS, I. M., HARVEY, S. T., BUCKLEY, L., & YAN, E. (2009). Differentiating classroom climate concepts: Academic, management, and emotional environments. *New Zealand Journal of Social Sciences*, 4(2), 131–146.
- [15] EYSENCK, M. W. (2012). *Fundamentals of cognition* (2nd ed.). New York, NY: Psychology Press.
- [16] FRASER, B. J. (1989). Twenty years of classroom climate work: progress and prospect. *Journal of Curriculum Studies*, 21(4), 307–327. doi: 10.1080/0022027890210402
- [17] FRASER, B. J. (1998). Classroom environment instruments: Development, validity and applications. *Learning Environments Research*, 1, 7–33.
- [18] GLASNOVIĆ GRACIN, D., & KUZLE, A. (2018). Drawings as external representations of children's mathematical ideas and emotions in geometry lessons. *CEPS – Center for Educational Policy Studies Journal*, 8(2), 31–53.
- [19] GRUEHN, S. (2000). *Unterricht und schulisches Lernen* [Teaching and school learning]. Münster, Germany: Waxmann.
- [20] HALVERSCHEID, S., & ROLKA, K. (2006). Student beliefs about mathematics encoded in pictures and words. In J. Novotná, H. Moraová, M. Krátká, & N. Stehlíková (Eds.), *Proceedings of the 30th Conference of the International Group for the Psychology of Mathematics Education* (Vol. 3, pp. 233–240). Prague, the Czech Republic: PME.
- [21] HANNULA, M. S. (2007). Finnish research on affect in mathematics: Blended theories, mixed methods and some findings. *ZDM – The International Journal on Mathematics Education*, 39(3), 197–203.
- [22] HANNULA, M. S. (2011). The structure and dynamics of affect in mathematical thinking and learning. In M. Pytlak, E. Swoboda, & T. Rowland (Eds.), *Proceedings of the Seventh Congress of the European Society for Research in Mathematics Education* (pp. 34–60). Rzeszów, Poland: University of Rzeszów.
- [23] KEARNEY, K. S., & HYLE, A. (2004). Drawing about emotions: the use of participant-produced drawings in qualitative inquiry. *Qualitative Research*, 4(3), 361–382.
- [24] KOSSLYN, S. M. (1980). *Image and mind*. Cambridge, MA: Harvard University Press.
- [25] KOSSLYN, S. M. (1988). Aspects of a cognitive neuroscience of mental imagery. *Science*, 240, 1621–1626.
- [26] KOSSLYN, S. M. (1994). *Image and brain: The resolution of the imagery discussion*. Cambridge, MA: MIT Press.
- [27] KUZLE, A., & GLASNOVIĆ GRACIN, D. (accepted). Classroom social climate in the context of middle school geometry. In *Proceedings of the 43rd Conference of the International Group for the Psychology of Mathematics*. Pretoria, South Africa: PME.
- [28] KUZLE, A., & GLASNOVIĆ GRACIN, D. (under review-b). Making sense of geometry education through the lens of fundamental ideas: An analysis of children's drawings.
- [29] KUZLE, A., GLASNOVIĆ GRACIN, & KLUNTER, M. (2018). Primary grade students' fundamental ideas of geometry revealed via drawings. In E. Bergqvist, M. Österholm, C. Granberg, & L. Sumpter (Eds.), *Proceedings of the 42nd Conference of the International Group for the Psychology of Mathematics* (Vol. 3, pp. 283–290). Umeå, Sweden: PME.
- [30] LAINE, A., AHTEE, M. (2017). Factors of positive emotional atmosphere: Case study of one primary school classroom. In M. Stein (Ed.), *A life's time for mathematics education and problem solving: Festschrift on the occasion of András Ambrus' 75th birthday* (pp. 232–241). Münster, Germany: WTM-Verlag.

- [31] LAINE, A., AHTEE, M., NÄVERI, L., PEHKONEN, E., PORTAANKORVA-KOIVISTO, P., & TUOHILAMPI, L. (2015). Collective emotional atmosphere in mathematics lessons based on Finnish fifth graders' drawings. *LUMAT – Research and Practice in Math, Science and Technology Education*, 3(1), 87–100.
- [32] LAINE, A., NÄVERI, L., AHTEE, M., HANNULA, M. S., & PEHKONEN, E. (2013). Emotional atmosphere in third-graders' mathematics classroom – an analysis of pupils' drawings. *Nordic Studies in Mathematics Education*, 17(3–4), 101–116.
- [33] LODGE, C. (2007). Regarding learning: Children's drawings of learning in the classroom. *Learning Environments Research*, 10, 145–156. doi:10.1007/s10984-007-9027-y
- [34] MALCHIODI, C. A. (1998). *Understanding children's drawings*. New York, NY: Guilford Press.
- [35] MAMMANA, C., & VILLANI, V. (1998). *Perspectives on the teaching of geometry for the 21st century: an ICMI study*. Dordrecht, The Netherlands: Kluwer.
- [36] MOOS, R. H., & MOOS, B. S. (1978). *Classroom social climate and student absences and grades*. *Journal of Educational Psychology*, 70(2), 263–269.
- [37] MZOS [Ministry of Science, Education and Sports]. (2006). *Nastavni plan i program za osnovnu školu* [Educational plan and program for elementary school]. Zagreb, Croatia: Ministry of Science, Education and Sports.
- [38] PEARSON, J., & KOSSLYN, S. M. (2015). The heterogeneity of mental representation: Ending the imagery debate. *Psychological and Cognitive Sciences*, 112(33), 10089–10092.
- [39] PEHKONEN, E., AHTEE, M., & LAINE, A. (2016). Pupils' drawings as a research tool in mathematical problem-solving lessons. In P. Felmer, E. Pehkonen, & J. Kilpatrick (Eds.), *Posing and solving mathematical problems. Advances and new perspectives* (pp. 167–188). New York, NY: Springer.
- [40] PEHKONEN, E., AHTEE, M., TIKKANEN, P., & LAINE, A. (2011). Pupils' conception on mathematics lessons revealed via their drawings. In B. Roesken & M. Casper (Eds.), *Proceedings of the MAVI-17 conference* (pp. 182–191). Bochum, Germany: Ruhr-Universität Bochum.
- [41] PHILIPP, R. A. (2007). Mathematics teachers' beliefs and affect. In F. K. Lester (Ed.), *Second handbook of research on mathematics teaching and learning* (Vol. 2, pp. 257–315). Charlotte, NC: Information Age.
- [42] PICKER, S. H., & BERRY, J. S. (2000). Investigating pupils' images of mathematicians. *Educational Studies in Mathematics*, 43, 65–94.
- [43] PITTA, D. (1998). *Beyond the obvious: Mental representations and elementary mathematics* (Unpublished doctoral dissertation). Mathematics Education Research Centre, University of Warwick.
- [44] REZAT, S., HATTERMANN, M., & PETER-KOOP, A. (Eds.). (2014). *Transformation – A fundamental idea of mathematics education*. New York, NY: Springer.
- [45] ROLKA, K., & HALVERSCHEID, S. (2006). Pictures as a means for investigating mathematical beliefs. In S. Alatorre, J. L. Cortina, M. Sáiz, & A. Méndez (Eds.), *Proceedings of the 28th Annual Meeting of the North American Chapter of the International Group for the Psychology of Mathematics Education*. Mérida, México: Universidad Pedagógica Nacional.
- [46] ROLKA, K., & HALVERSCHEID, S. (2011). Researching young students' mathematical world views. *ZDM – Mathematics Education*, 43(4), 521–533.

- [47] Senatsverwaltung für Bildung, Jugend und Wissenschaft Berlin, Ministerium für Bildung, Jugend und Sport des Landes Brandenburg. (2015). *Rahmenlehrplan Jahrgangsstufen 1-10. Teil C, Mathematik* [Framework curriculum Grades 1-10. Part C, Mathematics]. Berlin, Potsdam, Germany.
- [48] VAN DE WALLE, J., & LOVIN, L. H. (2006). *Teaching student-centered mathematics. Grades 5–8*. Boston, MA: Pearson.
- [49] VEALE, A. (2005). Creative methodologies in participatory research with children. In S. Greene & D. Hogan (Eds.), *Researching children's experience. Approaches and methods* (pp. 253–272). London, Great Britain: Sage.
- [50] THOMSON, P. (2008). *Doing visual research with children and young people*. London, Great Britain: Routledge.
- [51] TRICKETT, E. J., & MOOS, R. H. (1973). Social environment of junior high and high school classrooms. *Journal of Educational Psychology*, 65(1), 93–102.
- [52] TULVING, E. (1972). Episodic and semantic memory. In E. Tulving & W. Donaldson (Eds.), *Organisation of memory* (pp. 381–403). New York, NY: Academic Press.
- [53] TUOHILAMPI, L., LAINE, A., HANNULA, M. S., & VARAS, L. (2016). A comparative study of Finland and Chile: the culture-dependent significance of the individual and interindividual levels of the mathematics-related affect. *International Journal of Science and Mathematics Education*, 14, 1093–1111. doi: 10.1007/s10763-015-9639-0
- [54] WALLS, F. (2007). “Doing maths”: Children talk about their classroom experiences. In J. Watson & K. Beswick (Eds.), *Proceedings of the 30th Annual Conference of the Mathematics Education Research Group of Australasia* (Vol. 2, pp. 755–764). Adelaide, South Australia: Merga.
- [55] WEBER, S., & MITCHELL, C. (1996). Drawing ourselves into teaching: Studying the images that shape and distort teacher education. *Teaching and Teacher Education*, 12, 303–313.
- [56] WINTER, H. (1976). Was soll Geometrie in der Grundschule? [What should geometry be like in elementary school?]. *Zentralblatt Didaktik der Mathematik*, 8, 14–18.
- [57] WITTMANN, E. CH. (1999). Konstruktion eines Geometrieunterrichts ausgehend von Grundideen der Elementargeometrie [The construction of a geometry curriculum based on the fundamental ideas of elementary geometry]. In H. Henning (Ed.), *Mathematik lernen durch Handeln und Erfahrung. Festschrift zum 75. Geburtstag von Heinrich Besuden* (pp. 205–223). Oldenburg, Germany: Bueltmann und Gerriets.
- [58] ZAMBO, D. (2006). Using thought-bubble pictures to assess students' feelings about reading. *The Reading Teacher*, 59(8), 798–803.

Contact address:

Ana Kuzle
Department Lehrerbildung
Grundschulpädagogik Mathematik
Universität Potsdam
Karl-Liebknecht-Str. 24-25, 14476 Potsdam, Deutschland
e-mail: kuzle@uni-potsdam.de

Was können wir aus Schülerzeichnungen lernen? Visuelle Forschung in Mathematikdidaktik

Ana Kuzle

Department Lehrerbildung, Grundschulpädagogik Mathematik, Universität Potsdam,
Potsdam, Deutschland

Zusammenfassung. In den letzten zwanzig Jahren haben sich Methoden der visuellen Forschung in den Sozialwissenschaften durchgesetzt. In der visuellen Forschung gibt es verschiedene Möglichkeiten zum Erfassen mentaler Vorstellungen. Dazu zählen zum Beispiel Fotografien, Videoaufnahmen oder Zeichnungen. Die Wurzeln der visuellen Forschung liegen im Schwerpunkt auf der psychologischen Haltung. In letzter Zeit verlagerte sich in Mathematikdidaktik der Fokus jedoch auf die Verwendung von Zeichnungen als Ausdruck von u.a. Schülervorstellungen zum Mathematikunterricht und kognitiven (Annahmen und Überzeugungen), affektiven (Gefühle und Emotionen) und behavioralen (Verhaltensweisen) Einstellungen der Schüler*innen. Insbesondere “participant-produced drawings” ermöglichen einen ko-konstruktiven Prozess des Denkens in Aktion, anstatt Zeichnungen als einfache Darstellungen der Teilnehmerwirklichkeit zu betrachten. In diesem Paper diskutiere ich die zahlreichen Verwendungsmöglichkeiten von Zeichnungen in mathematikdidaktischer Forschung. Insbesondere fokussiere ich Schülerzeichnungen um einen non-verbalen Einblick in die Wahrnehmungen der Schüler*innen über das geometrische Lernklima aus kognitiver, sozialer und emotionaler Perspektive zu erlangen.

Schlagwörter: Zeichnungen, fundamentale Ideen, Unterrichtsklima, emotionales Klima, visuelle Forschung

Relationship between the Poly-Universe Game and mathematics education

Eleonóra Stettner

Methodological Institut, Kaposvár University, Hungary

Abstract. The main objective of Erasmus+ Poly-Universe in School Education (PUSE) project is to develop a new visual system for mathematics education: the Poly-Universe Methodology. The project is based on the Poly-Universe game, which is a geometric skill development game by János Szász SAXON fine artist. The novelty of Poly-Universe lies in the ‘scale-shifting’ symmetry inherent to its geometric forms and a color combination system, which can be used universally and impact the educational system, particularly in the education of geometry and combinatorics. The complexity emerging out of Poly-Universe’s simplicity makes it more than a game, more than art, more than mathematics: these elements come all together – creating synergy in education.

Teachers from four countries take part in the project (Finland, Spain, Slovakia and Hungary). They discover Poly-Universe Game-based tasks, compile a collection of tasks, develop an educational methodology and try them out in school education. It is very interesting to see how the different educational practices of different countries are reflected in the tasks and methods of the teachers from each country.

In the paper I present the experiences and results of the project so far and present some interesting tasks.

Keywords: Poly-Universe, manipulatives, combinatorics, geometry, GeoGebra

1. Introducing the Inventor of the Poly-Universe Game

János Szász SAXON was born in 1964, in Tarpa, and he is a freelance Hungarian creative artist, inventor, editor, art organizer and museum founder, www.saxon-szasz.hu. His masters were Tibor Csiky, sculptor, János Fajó, painter (Budapest) and Carmelo Arden Quin, MADI artist (Paris). At the beginning of his career it was Kazimir Malevich, Russian suprematist painter, the creator of ‘world as objectlessness’, who had the greatest spiritual influence on him. In the 80s the

artist created abstract-geometric, constructivist art works. Since the early 90s he has been participating in the international movement MADI, and with his wife, Zsuzsa Dárdai he set up the Mobil MADI Museum, the world's largest MADI collection: www.mobilemadimuseum.hu.

In the 90s he developed his unique system of poly-dimensional planar painting, and after that the related skill development devices called Poly-Universe: www.poly-universe.com.

The project **Erasmus+ PUSE (Poly-Universe in School Education)** gave him the opportunity to develop a new, visual, experience-centred mathematics education methodology. The project is based on Poly-Universe, the geometric skill development game invented by him. The novelty of the device is in the scale-shift symmetry of the basic shapes and the related color combination system. The inventor developed his device from the symbiosis of 'geometric form language', the 'polydimensional' artistic vision and the 'free/open forms' proclaimed by MADI, during a scholarship in South France, where he had the opportunity to join the activity of the pedagogical workshop.

According to the inventor of Poly-Universe:

'Poly-Universe can be used widely in different age groups. It may have an impact on mathematics education, and it can be especially useful in the fields of geometry, logic, graphs and combinatorics. Due to the complexity of the set's simplicity it is more than a game, more than art or mathematics, because it is all of these: **synergy in education ...**'

In the project, this opinion was confronted with the ideas and experience of practicing mathematics teachers from the four countries.

2. A description of the elements of Poly-Universe

The Poly-Universe set is made up of three basic shapes: triangle, square, and (almost) circle. The colors are: red, yellow, green, and blue. The shapes are colored in every possible way using these four colors. The sides of the triangle and the square, and the diameter of the 'circle' is 9 cm, their thickness is 0.5 cm, having the same color on both sides. At the vertices of the triangle element, the sides of the smaller colored triangles are half, fourth, eighth of the side of the original triangle. The square element is similar. Here, there is a square-shaped 'hole' at the fourth vertex, whose side length is $1/16$ of the original square side, so that we can also color the square element with the above mentioned four colors. There are three semicircles attached to the boundary of the circle in directions making 120° angles with one another, the largest has a radius that is half of the original circle, for the medium it is one fourth, and for the smallest it is one eighth. The diameters of the three semicircles cut off three segments from the original circle so the basic form is not exactly a circle. (So this shape is bordered by 3 arcs and 3 line segments, so they can stand on their line segment parts in a stable way, as kids tried it.) The forms having the same shape and colored in all possible ways are packed in a box, Figure

1. It can also provide a combinatorial task to calculate the number of elements in one box or the number of ways the given quantity can be placed in the box.



Figure 1. The 3 basic forms.

3. About the project in general

Project goal: To develop and test PUSE, a mathematical educational methodology for EU schools in cooperation with participant teachers and students. The project lasts for 21 months, it will finish on 31 June, 2019.

The participants of the project were teachers and their student groups from 4 countries:

Budapest Fazekas Mihály Practicing Primary School and Grammar School, Budapest, Hungary, Nafarroako Ikastolen Elkartea, Pamplona, Comunidad Foral de Navarra, Spain,

Základná škola Gergelya Czuczora s vyučovacím jazykom maďarským, Nové Zámky, Slovakia, and 2 Finnish schools coordinated by the Experience Workshop, Jyväskylä, Keski-Suomi, Finland.

In addition, our partner was NetCoGame GamefulLiving Research Center Nonprofit Ltd, Budapest, who made the measurements.

Measurements were made in three age groups, on two occasions, before and after using the device. Besides, measurements were performed in each country, simultaneously, in control groups. Students used the game 5-6 times, for 1-2 hours. Tests were made in the following fields: attention, visual perception, short time memory, mental rotation, attitude for their school and mathematics. The five-month developing period demonstrated that the PUSE activity had a positive influence on visual perception, and strongly supported the emergence of positive attitude towards mathematics. It certainly does not mean that the other examined fields were not positively influenced by Poly-Universe, but that the five-month period was probably too short to achieve detectable improvement.

The most important activity of the project was the development of a methodological book, which, in its final version, consists of teacher and student worksheets. In addition, a website is going to be created, from where the book can be downloaded, and where anybody can upload their own tasks inspired by Poly-Universe.

In the participating schools, on average 3-5 teachers took part in the development of the tasks, which they immediately tried out with their students. Then, in their own school, everybody held a short training for their colleagues, who in turn tested the tasks with their own student groups, and with these feedbacks the task collection was improved and shaped. The effectiveness of the work was enhanced by 4 project meetings held in the participating schools of the four different countries, where we could share our ideas and experiences in person. Finally, in June 2019, we would like to share the experiences and results of the project with the wider public, and in each country, teachers from the participating schools are going to hold lectures and workshops for teachers and educational experts from other schools.

4. PUSE chapters

The use of manipulatives in the course of mathematics learning and education looks back on a history of several millennia. Mathematical abstraction was already connected to manipulation with different objects (sticks, stones) in ancient Chinese, Sumer, Egyptian or Greek cultures (Wintsche, Emese 2018).

The use of manipulatives in order to improve mathematics education has many opportunities. It is however insufficient to put manipulatives into children's hands without incorporating them in a well thought out way into the learning process, through applying the suitable methodology (Swan, Marshall, 2010). The present compilation intends to be a guide exactly for this purpose.

The methodological part of the PUSE book is divided into five chapters. Each chapter is made up of methodology sheets meant for teachers, paired with student worksheets. They are numbered according to the chapters listed below. The numbering of teacher sheets is identical with those of the student sheets, only their colour differs.

- 1 Geometry and measurement
- 2 Combinatorics and probability calculations
- 3 Sets and logic
- 4 Graphs and Algorithms
- 5 Complex

At the beginning of the PUSE book you can find a glossary. This is a practical tool enabling teachers who work in different countries and teach different age groups, to use the same unified terminology.

When we first get in touch with the Poly-Universe set and start to think about which chapter of mathematics we could use it for best, then combinatorics, probability calculations come first to mind, and geometry comes second. That's why we, the editors of this book were somewhat surprised to see that in the end, most of the exercises in almost all age groups belong to the geometry chapter, while additional, partly geometry-related exercises are included in the complex chapter as well.

Among the student worksheets there are those suitable for classroom use, which specifically relate to concrete parts of the curriculum, and help to acquire knowledge in a direct and playful way. Some of the exercises of the selection suit after-school sessions better, others require longer project work spanning several days, while some others involve intense thinking and reach the complexity of maths competition exercises. Similar suggestions to the possible uses are included in the teacher methodological sheets' recommendation section.

In the headings of each exercise sheet we indicated the type of equipment needed, the topics and sub-topics the given worksheet belongs to, the level of difficulty and the age group. The Poly-Universe methodology differentiates between three levels according to age groups:

1. Worksheets A are for 6–10 year olds
2. Worksheets B are for 10–14 year olds
3. Worksheets C are for age 14–18

One might of course even further differentiate within a given age group, for example within A there are exercises for 8-10 or within B for 12-14 year olds, always depending on the curriculum of the grade which the methodology can be attached to. Age groups often overlap, for example, there are AB and BC worksheets as well. Categories indicating levels of difficulty and age can be used flexibly, if not entirely freely, since there are talented children everywhere, and tasks for smaller ones can also be exciting for older children - this is up to the teachers' decision.

It was very interesting to observe the differences in exercises from different countries. Hungarian teachers' exercises focused on pure mathematics, while Spanish colleagues put artistic creation to the forefront (traceable in the selection of beautiful pieces in the exercise book as well).

Our main goal was to explore the mathematical possibilities of the Poly-Universe tool and to transform these findings into a methodology. Therefore, most of our exercises are in direct relationship with the tool, and the solution of a problem requires creating shapes, involvement in play and experiments. There are tasks in the C age group however, which use the tool as a starting point, a source of ideas only, and take us to really complicated complex problems and generalizations.

It's impossible to ignore the fact that children nowadays live a part of their lives in the digital space. With the help of GeoGebra, we have developed interactive programs for the design and further consideration (such as the three-dimensional extension) of the spatial-geometric elements reflecting on the artistic backgrounds of Poly-Universe. But we can as well use GoogleDraw for example for free play, or for the digital modelling of exercise solutions which involve more Poly-Universe sets, or even for creating projects inspired by fractal geometry – to broaden children's perspective.

One of Poly-Universe's and the related exercises' great advantages is that the game and the thinking process often take place in a group framework, and encourage the children to cooperate.

While compiling the methodological worksheets, we were surprised to see how wide the spectrum of exercises actually was both in terms of subjects and degree of difficulty. From the simplest playful exercises for the smallest ones, through the world of combinatorics, we arrive at exercises involving profound thinking, suitable even for higher education and maths olympiads.

We are convinced that the present PUSE methodological book is only the beginning. New ideas are constantly coming up, and Poly-Universe contains almost endless possibilities – so that the related methodology cannot be closed down either. We hope that the exercises inspired by the tool will evoke new ideas in both teachers and students using the collection. We would be pleased to see those ideas shared on the Poly-Universe website (<http://www.poly-universe.com/>).

4.1. Geometry and measurement

This chapter has turned out to be the most extensive and the richest among all. It includes a lot of tasks for all ages, while geometric content is nonetheless part of the complex chapter, with exercises overarching other areas as well.

Children, especially of high school age, use calculators. Nevertheless, it is quite important to be able to decide whether the obtained result is at least proportionally acceptable. These experiences are ideally abundantly gained at primary school lower grades – see age group A geometrics exercises of this book. Some of the exercises begin with measurements, then continue with area and perimeter calculations (the former only in the case of the square). Later on, due to scale shift symmetry, side length can be halved, so that perimeter and area calculations will be possible to do not only by empirical experience but by drawing conclusions as well.

By answering the questions posed in the exercises, students can gain experience of geometrical transformations, types of rectangles, convex, concave shapes, and learn the concept of vertex and side. They can among other things cover different shapes with squares, triangles and circles, thereby gaining experience about how to fill the plane without gaps, how to estimate and measure the area.

In age group B, besides conventional counting exercises such as the sum of polygon angles, perimeter and area calculations, there are simple proofing, construction tasks and even exercises meant for maths talent development as well.

Of course, in age group C, there are all the problems related to usual high school topics available, such as calculating the sides, angles and area of the scalene by using trigonometric relations. Aspects of the circle are also thoroughly explored by one of the exercises. In these exercises, the Poly-Universe tool's real measurements can be applied, or maybe their easily divisible versions, and also parametrically. If possible, it's worth constructing the shapes in GeoGebra for the sake of control.

Perhaps the most exciting section in this part of the book is a series of 5 worksheets, which sets out from the area calculations of a specific Poly-Universe

element, then generalizes step-by-step, eventually reaching the level of a not-so-easy competition exercise.

4.2. Combinatorics and probability calculations

“There are areas of mathematics where Hungarian research belongs to the forefront of the world. The predecessors and descendants of Pál Erdős made combinatorics practically a “Hungarian science”. This discipline was originally based on playful, puzzle-like problems, but with the appearance of the computer, it turned out to be one of the most important foundations of computer science. This has recently led to an explosive development.” (Katona, 2006)

Most of the combinatorics exercises cannot be solved mechanically, but they require critical thinking and strategic planning, which improve mathematical performance and are excellent for both subject-centred and multidisciplinary concentration.

Poly-Universe’s structure, colour, and size varieties are inexhaustible sources for combinatorics tasks. Indeed, this chapter contains a rich diversity of materials for all ages in the areas of combinatorics and probability calculations.

In age group A, combinatorics tasks examine the possibilities of combining two elements only, and offer students the chance to formulate a rule on their own by free play and experimentation. Probability calculations help to prepare the understanding of the concept of probability by experimentation.

Many of the B-age group worksheets contain free play as well (see the Tangram-type exercises), but wherever possible, students are already asked about the number of combination possibilities. Thus, these tasks already require some combinatorics experience. Geometry as well is present in these exercises, because specific symmetries or particularities originating from the elements’ structure have to be taken into account when solving a problem.

The exercises for age group C are based on the traditional combinatorics knowledge of secondary schools, such as permutations, combinations, variations, combinatorial probability. Some of the exercises highlight in how many different ways Poly-Universe can be combined. The results are often unimaginably high numbers, worth comparing with very large numbers familiar to students, such as astronomical distances, the age of the celestial bodies expressed in seconds, the GDP data of large countries, the population of humanity, etc.

One of the most difficult exercises in combinatorics is to find the mistake in “seemingly” good solutions, which is why we included false, troubleshooting exercises as well. It is important to know that the exercises for different age groups in this chapter are connected, they build upon each other. These connections are also indicated on the worksheets. It makes sense to solve these exercises one after another so that the students can grasp how a solution can be traced back to an exercise already solved.

We basically rely on the tool set in this age group as well. The solution comes easier through individual cases. In some cases, we would like to lay down several possible solutions in order to understand the exercise, although we don't provide many sets. Therefore, it is worth to save the cases already laid down in one form or another. This can be a drawing, a smartphone photo, or an image of digitalized Poly-Universe elements combined into a new design.

The exercises at the end of this chapter go beyond the framework of traditional secondary school education, to find their place in mathematics specialization classes or in higher education. Here the concepts of binomial coefficients, expected value, total induction, fixed points of permutations and the principle of logical sieve appear.

An exercise for age group B can be found in Appendix B.

4.3. Sets and logic

The sets and logic chapter contains exercises for age groups A and B. The structure of the Poly-Universe tool itself offers the possibility of grouping, sorting into sets individual elements or groups of elements, and of formulating true-false statements. Thus, these exercises are very suitable for an introduction to elements of mathematical logic (on different levels depending on the age group). Logical operations such as negation, conjunction, disjunction, implication and complex operations deriving from them, and also quantifiers (all, there is and their denials) occur among the exercises.

Here, free play, observation, acquaintance with elements' names, observational skill development, free thinking, finding the often not single right solution of a task, formulating own rules and open sentences – are important.

An exercise for age group A is in Appendix C

4.4. Graphs and algorithm

In several age groups, we may ask how many Poly-Universe elements are placed in a box.

One of the obvious ways of systematic organization is the representation with a tree graph. The basic elements' structure naturally offers coding by colour initials and the descending order of different size fields. Teachers in all countries, independently of each other, integrated this into their exercises.

The stacking of specific Poly-Universe elements in different ways, but also their different rule governed layouts can be transformed into graph theory exercises. In order to do this, we should imagine what a graph looks like related to a given exercise, in which each vertex of a graph is a Poly-Universe element; there are edges between two vertices only in case the two elements can be placed on top of or next to each other according to the given rule.

It is possible to create many combinatorics exercises in which the layout of the chosen shapes is conditional after a few steps and depends on the elements already used up. It is worth writing an algorithm for these exercises in order to analyse solvability and the number of solutions. Subject for further research could be the writing of algorithms and computer programs for exercises presently seeming unsolvable – in order to determine whether they are really unsolvable or if not, how many solutions they have.

Such a task that has not yet been resolved:

Using two complete sets ($2 \times 24 = 48$ base elements), put out a large 7×7 square shape with a center hole, same color and size connection

There were two solutions in the workshops so far, but the hole was not in the middle in any of the cases. One solution can be seen in Figure 2.

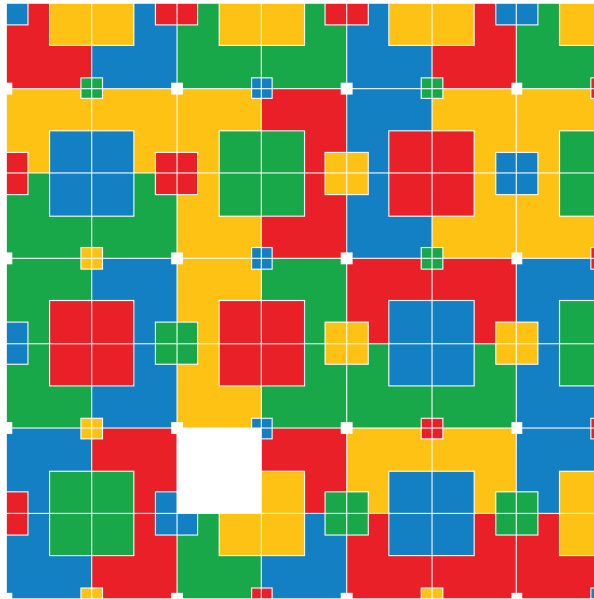

Figure 2. Large 7×7 square shape, same colour and size connection.

4.5. Complex

It was necessary to add the complex chapter for several reasons. On one hand, there are subject matters not covered by any of the chapters (e.g. Age group fractions, creation of rule-based series, Age group divisibility, total induction). On the other hand, there were exercises containing questions with references to multiple topics. We didn't break down these exercises, because they form a complex entity and thus throw a light upon how concentrated mathematics is within the subject.

A nice example of interdisciplinarity is an exercise based on the connection between mathematics and art, starting out from Platonic solids and inspiring

excursions into the world of art compositions. It demonstrates the inseparable, omnipresent intertwining of science and art, and it can even be linked by Poly-Universe elements with a strictly mathematical proving.

This chapter includes GeoGebra- and GoogleDraw-based exercises, fractal structure and 3D pieces, visual games referring back to Poly-Universe's background in art.

Here are the introductory, memory-developing exercises, games (domino with Poly-Universe), open-ended project tasks which require creating collages and economic planning, but include geometric- and per cent calculations as well.

Finally, the Tangram-type puzzles, abundant in both A and B age groups are also included in this chapter. We especially recommend these exercises to further develop children's creativity. After having completed one or two exercises, children could be motivated to think and collect their own ideas so that the class in the end provides its own Poly-Uni-tangram database.

Here is a task using GeoGebra in Appendix D.

5. Conclusions

Nowadays, the whole educational system, the teaching profession and teacher training are facing great challenges. They are looking for new answers to new questions. Teachers motivated in achieving successful cooperation between teachers and students are looking for helping tools and methods all over the world. The pedagogical methodological book and workbook developed from the Poly-Universe skill development tool provide a solution in this process.

The Erasmus +PUSE project was the first step to map how Poly-Universe can convey its artistic-scientific approach, under classical conditions in mathematics education. The demand was provided by workshops held in a dozen countries in the last decade and by participation in international mathematics-artistic conferences (Bridges, Esma, ExperienceWorkshop, RISD, Symmetry, Synergetics, ULB, etc.).

Stimulating motivation, interaction, creating interest, and experience-centred education are also important in teaching. Space must be allowed for imagination and discovery; students should be motivated and given the opportunity to look for connections between visual, tangible patterns, creative and playful solutions, rather than wandering in the world of abstract numbers when searching for solutions for mathematical problems.

Through the international partnership, we learnt how students and teachers approach the visual, experience-centred task solution in a Scandinavian type of education, such as the Finnish, in the Central European conservative educational system, in Western-European environment based on the Pisa method, and in the special circumstances of minority schools. Each participating school provided significant added value in developing methods, techniques, and ideas.

Poly-Universe is not only a simple tangible tool or a well-defined puzzle, but also an artistic-mathematical system open in all directions. As a result, the methodological book, PUSE (Poly-Universe in School Education) is not a closed, didactic task collection, either. The web-based platform open to everyone allows the continuous development of the PUSE methodology, and the upload of new tasks and ideas to all creative teachers and students.

References

- [1] WINTSCHE G. AND EMESE GY. (2018). *The Changing Usage of Teaching Tools in Hungary*. CADGME Coimbra.
- [2] SWAN P. AND MARSHALL L. (2010). Revisiting Mathematics Manipulative Materials. *APMC*, 15(2).
- [3] KATONA GY. (2006). *How did combinatorics become “Hungarian mathematics”?* Mindentudás Egyeteme lecture. Retrieved February 16, 2019 from <http://www.origo.hu/itthon/20060514katona1.html>

Appendices

Appendix A

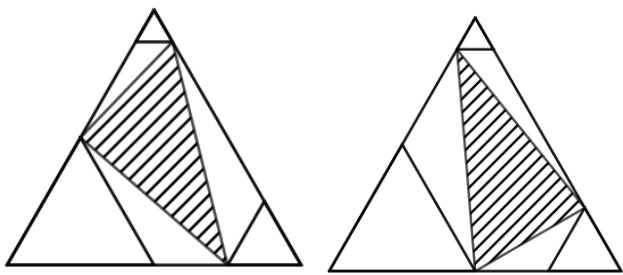
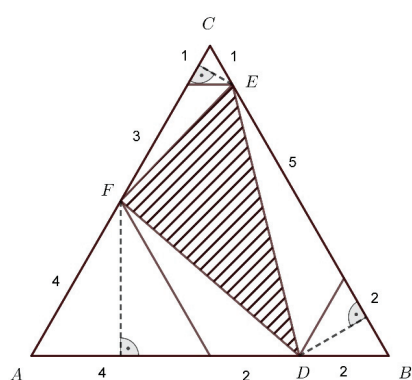
	<p>Grade C / Age: 14-18 Operation: geometry, triangle, area, trigonometry Sets: triangle Tools more: paper, crayon Language: English</p>	<p>TEACHER PUSE Task Number C 138</p>
<p>Description of the Task:</p> <ol style="list-style-type: none"> 1. What fraction is the shaded part of the whole? 2. What fraction is the shaded part of the whole? (Watch out! It's not the same as the previous one.) <div style="text-align: center;">  </div>		
<p>1/ Solutions of the Task:</p> <p>For the sake of simplicity, the sides of the triangle are 8 units long. Then the figure looks like this. The area of the triangle with side length a is $A = \frac{a^2\sqrt{3}}{4}$.</p> <div style="text-align: center;">  </div> <p>$A_{ABC} = 16\sqrt{3}$</p> <p>The area of the triangle EFD is determined by subtracting the area of the triangles ADF, DBE and ECF from the area of the triangle ABC. Since the heights of the triangles are equal to the corresponding 4, 2, and 1 sides, so:</p> $A_{ADF} = \frac{6 * 2\sqrt{3}}{2} = 6\sqrt{3}.$		

$$A_{BED} = \frac{7 * \sqrt{3}}{2} = 3,5\sqrt{3}.$$

$$A_{CEF} = \frac{4 * \sqrt{3}}{2} = \sqrt{3}.$$

$$\text{So } A_{DEF} = 16\sqrt{3} - 6\sqrt{3} - 3,5\sqrt{3} - \sqrt{3} = 5,5\sqrt{3}.$$

The ratio of the shaded area to the whole is therefore nothing more $\frac{A_{DEF}}{A_{ABC}} = \frac{5,5\sqrt{3}}{16\sqrt{3}} = \frac{11}{32}$.

2/ Solutions of the Task:

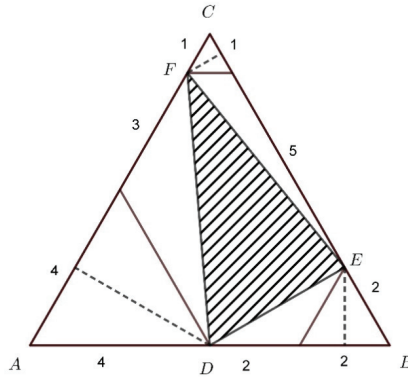

For the sake of simplicity, the sides of the triangle are 8 units long. Then the figure looks like this. The area of the triangle with side length a is $A = \frac{a^2\sqrt{3}}{4}$.

$$A_{ABC} = 16\sqrt{3}$$

The area of the triangle EFD is determined by subtracting the area of the triangles ADF, DBE and ECF from the area of the triangle ABC. Since the heights of the triangles are equal to the height of the regular triangles with the corresponding 4, 2, and 1 sides, so:

$$A_{ADF} = \frac{7 * 2\sqrt{3}}{2} = 7\sqrt{3}.$$

$$A_{BED} = \frac{4 * \sqrt{3}}{2} = 2\sqrt{3}.$$

$$A_{CEF} = \frac{6 * \sqrt{3}}{2} = 1,5\sqrt{3}.$$

$$\text{So } A_{DEF} = 16\sqrt{3} - 7\sqrt{3} - 2\sqrt{3} - 1,5\sqrt{3} = 5,5\sqrt{3}.$$

The ratio of the shaded area to the whole is therefore nothing more $\frac{A_{DEF}}{A_{ABC}} = \frac{5,5\sqrt{3}}{16\sqrt{3}} = \frac{11}{32}$.



Grade C / Age: 14-18

Operation: geometry, triangle, area, trigonometry

Sets: triangle

Tools more: paper, crayon, ruler

Language: English

TEACHER

PUSE Task Number

C

139

Description of the Task:

In the previous exercises, we have seen that when the side lengths of an AGF, BHD and CIE triangles are half, one quarter, eighth of the original ABC triangle, then the EDF and GHI triangles were the same (both $11/32$).

Is the statement true even if the aspect ratios of the triangles are not 1: 2: 4: 8?

That is, the task: A given ABC is a regular triangle in which FG, DH, EI are sloping slots parallel to the opposite sides. Is it true that $T_{GHI} = T_{DEF}$?

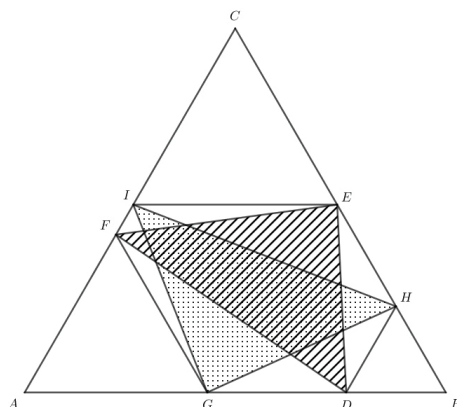

Solutions of the Task:

For the sake of simplicity, the length of the sides of the ABC triangle is 1 unit, the triangle AFG is a , the triangle BHD is b , and the triangle CIE is c .

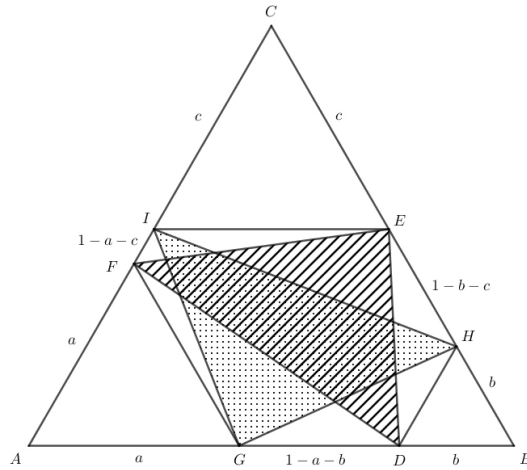

The area of the triangles DEF and GHI is determined by subtracting the area of the corresponding triangles from the area of the triangle ABC .

We can calculate the area of the appropriate triangles in many ways, now we use the $A_{\Delta} = \frac{a \cdot b \cdot \sin \gamma}{2}$ formula.

$$\begin{aligned} \text{So } A_{DEF} &= A_{ABC} - A_{ADF} - A_{BED} - A_{CFE} = \frac{1 \cdot 1 \cdot \sin 60^\circ}{2} - \frac{a \cdot (1-b) \cdot \sin 60^\circ}{2} - \frac{b \cdot (1-c) \cdot \sin 60^\circ}{2} - \\ &\frac{c \cdot (1-a) \cdot \sin 60^\circ}{2} = \frac{\sin 60^\circ}{2} \cdot [a(1-b) + b(1-c) + c(1-a)] = \frac{\sin 60^\circ}{2} \cdot (a + b + c - ab - ac - \\ &bc). \end{aligned}$$

$$\begin{aligned} A_{GHI} &= A_{ABC} - A_{AGI} - A_{BHG} - A_{CIH} = \frac{1 \cdot 1 \cdot \sin 60^\circ}{2} - \frac{a \cdot (1-c) \cdot \sin 60^\circ}{2} - \frac{b \cdot (1-a) \cdot \sin 60^\circ}{2} - \\ &\frac{c \cdot (1-b) \cdot \sin 60^\circ}{2} = \frac{\sin 60^\circ}{2} \cdot [a(1-c) + b(1-a) + c(1-b)] = \frac{\sin 60^\circ}{2} \cdot (a + b + c - ab - ac - \\ &bc). \end{aligned}$$

So the area of the two triangles is the same.

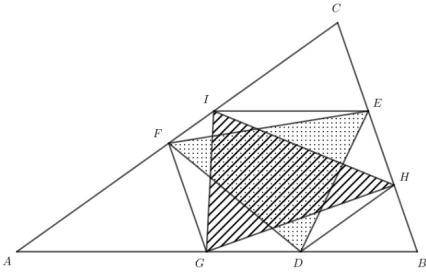
	<p>Grade C / Age: 14-18 Operation: geometry, triangle, area, trigonometry Sets: triangle Tools more: paper, crayon, ruler Language: English</p>	<p>TEACHER PUSE Task Number C 140</p>
<p>Description of the Task:</p> <p>Is the statement true even if the original triangle is not regular? That is, the task is: A given ABC general triangle, in which FG, DH, EI are sloping slopes parallel to the opposite sides. Is it true that $T_{GHI} = T_{DEF}$?</p> <div style="text-align: center;">  </div>		
<p>Solutions of the Task:</p> <p>Consider the uniform scaling between the $AFG, BDH,$ and CIE triangles as the vertices $A, B,$ and C of the triangle ABC, where the ratio of similarity is $a, b,$ and c respectively. We know that the ratio of the area is quadratic with the proportion of similarity, So the ratio of the area of the triangle AFG to the area of triangle $ABC = a^2: 1$. If the ratio of the AF section to AC is the ratio of the BD section to AB b, then the ratio of the AD side to AB is $1-b$. Let's try to determine the ratio of the area of the triangle AFD to ABC. We know that $AGF: ABC = a^2$ and we also know that the heights of the triangles AGF and ADF triangles are the same, the ratio of their base to $a : 1-b$, so the ratio of their areas also varies with the sides. That is, $AGF: ADF = a^2: (1-b)$. So $ADF: ABC = a(1-b)$. BDE, CEF triangle areas are similar to ABC and $b(1-c)$ and $c(1-a)$. The area of the triangles DEF and GHI is determined by subtracting the area of the corresponding triangles from the triangle ABC.</p> <p>So $A_{DEF} = A_{ABC} - A_{ADF} - A_{BED} - A_{CFE} = 1 - a(1-b) - b(1-c) - c(1-a) = (1 - a - b - c + ab + ac + bc)$.</p> <p>$A_{GHI} = A_{ABC} - A_{AGI} - A_{BHG} - A_{CIH} = 1 - a(1-c) - b(1-a) - c(1-b) = (1 - a - b - c + ab + ac + bc)$.</p> <p>So the area of the two triangles is the same. In a slightly different way:</p>		

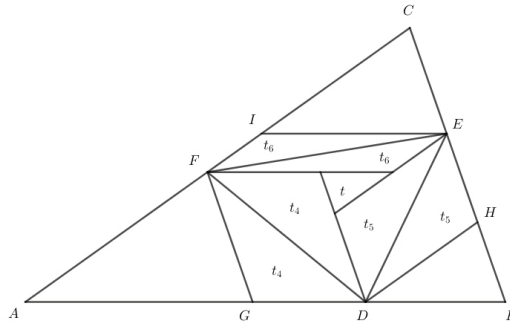
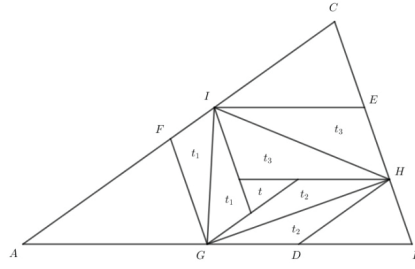

Consider the $FGDHEI$ hexagon. Pull once at the intersection of the points G, I, H with the corresponding sides or points D, E and F as well. Thus, our hexagon decomposes into 7 triangles, the area of which is in pairs, because the diagonals of the parallelogram divide the area of the quadrilateral. The middle triangle in the two different figures is coincident because its sides are evenly long in pairs, since the sides are $IE - GD, DH - IF, FG - EH$. Because the two hexagons are the same, so are their areas: $2t_1 + 2t_2 + 2t_3 + t = 2t_4 + 2t_5 + 2t_6 + t$, if we remove t from both sides and divide by 2 then $t_1 + t_2 + t_3 = t_4 + t_5 + t_6$, then adding t to both sides $t_1 + t_2 + t_3 + t = t_4 + t_5 + t_6 + t$,
 $A_{GHI} = A_{DEF}$;

With this we proved the claim.



Grade C / Age: 14-18
Operation: geometry
Sets: triangle, square
Tools more: paper, crayon, ruler
Language: English

TEACHER
 PUSE Task Number
C
141

Description of the Task:

Is the statement true even if we start out from a triangle instead of a square?

That is, the task is: A given ABCD square in which LE, IF, JG and KH are sloping slots parallel to the square diagonals. Is it true that $T_{EFGH} = T_{IJKL}$?

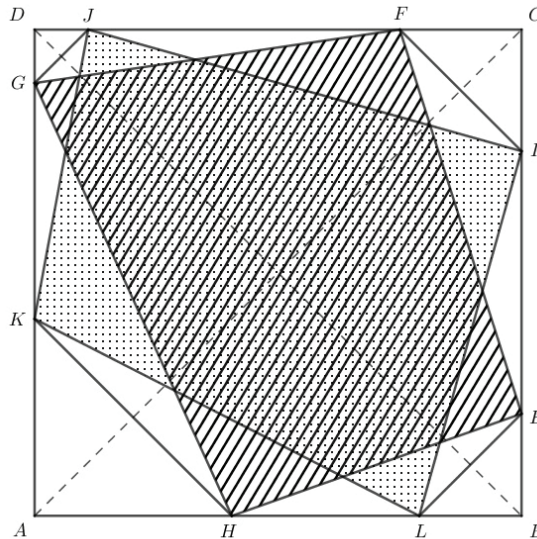

Solutions of the Task:

Let us denote the lengths of the following sections in the following way

$$AH = AK = a, BE = BL = b, CF = CI = c, \text{ and } DG = DJ = d.$$

We can assume that the length of the sides of the square is a unit. So calculate the area of the

$EFGH$ quadrilateral as follows: $A_{EFGH} = A_{ABCD} - A_{AHG} - A_{BEH} - A_{CFE} - A_{DGF}$;



$$\text{So } A_{EFGH} = 1 - \frac{a(1-d)}{2} - \frac{b(1-a)}{2} - \frac{c(1-b)}{2} - \frac{d(1-c)}{2};$$

Now calculate the area of the $IJKL$ quadrilateral in a similar way.

$$\text{We get the following expression for this: } A_{IJKL} = 1 - \frac{a(1-b)}{2} - \frac{b(1-c)}{2} - \frac{c(1-d)}{2} - \frac{d(1-a)}{2};$$

If you expand the parentheses, you can see that the two terms are the same, so the two quadrilaterals are the same.

Appendix B

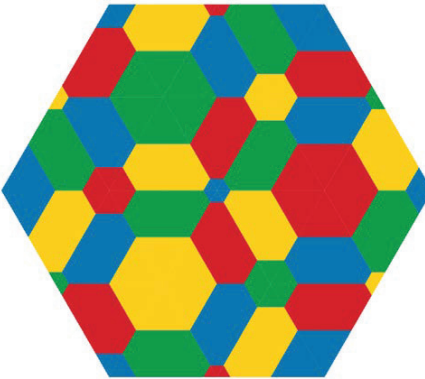
	<p>Grade B / Age: 10-14 Operation: combinatorics Sets: triangle Tools more: paper, crayon Language: English</p>	<p>TEACHER PUSE Task Number B 123</p>
<p>Description of the Task:</p> <p>a) Build the smallest possible regular hexagon, such that the joints are of equal length and the same colour. How many of these can be built from a triangle set? (They do not have to be built simultaneously; you can deconstruct them if you do not have enough elements. Two constructions are different if there is an element that has different neighbours in the constructions)</p> <p>b) Use the whole set to construct a regular hexagon, such that each joint is of equal length and of the same colour. How many different constructions are there this time?</p>		
<p>Solutions of the Task:</p> <p>a) Because all joints are of the same colour, we will have a monochromatic hexagon in the middle, and for every such, there is only one solution, so we have 4 colours * 3 sizes=12 solutions Some examples:</p> <div style="display: flex; justify-content: space-around; align-items: center;">  </div> <p>a) From part a) we can start the building in 12 ways. But after that our hands are tied, since there is only 1 good element to continue to every place, so there are at most 12 solutions. (2 colours are defined by the joints, and the other two colours can only be swapped with each other. Since we are using one set, these can be only the triangle we are joining with and the triangle we are joining to.) Having 12 solutions can be checked by construction. Some examples:</p> <div style="text-align: center;">  </div>		

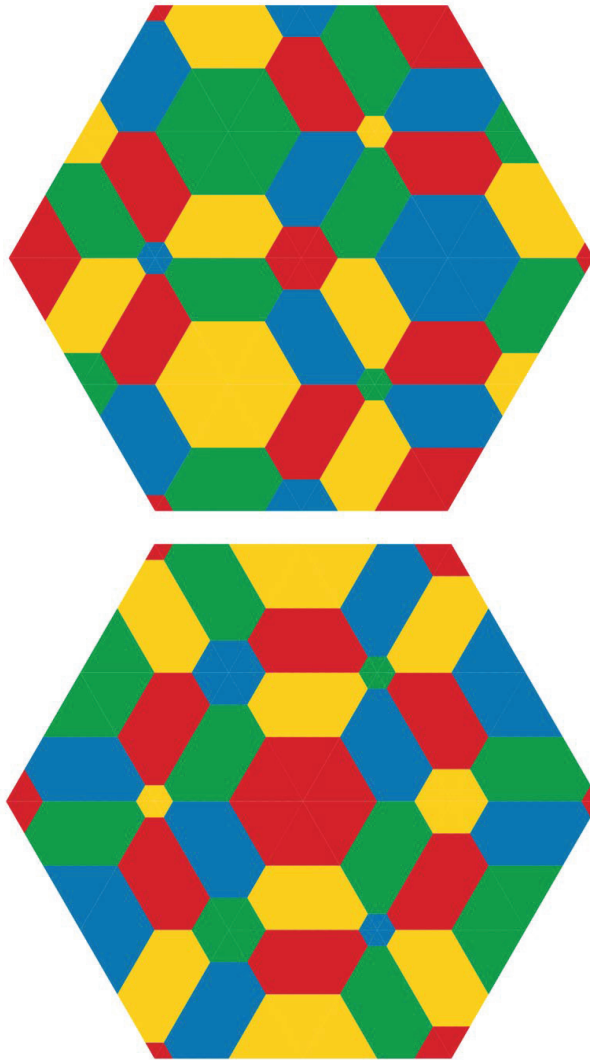



Precognition:

Recommendation:

For us to see all 12 different solutions without getting bored, students should start with different beginnings and then check each others.

Appendix C

	<p>Grade A / Age: 6-8 Operation: sets, logic, labelling, sorting Sets: square Tools more: Language: English</p>	<p>TEACHER PUSE Task Number A 304</p>
<p>Description of the Task: Sort out the follow items on the picture from the square set!</p> 		
<p>Solutions of the Task: Work with less pieces (5-6 items) for 6-7 years old, 8-10 items for the 7-8 years old children. Watch the squares, and continue the open sentences in many ways! For example: There are among them the most of which is yellow/green/red/blue. There are among them the smallest part of which is yellow/green/red/blue. There is none among them which contains more than 4 colours. There is none among them which isn't square. There is none among them which has a curved line. It is true for all of them that it is square. It is true for all of them that it hasn't a curved line. It is true for all of them that it is 4 colours. It is true for none of them that it has a curved line. It is true for none of them that it is unicoloured. It is true for none of them that it is triangle.</p>		
<p>Precognition: Children should get to know and play freely with the PUSE sets (circle, square, triangle). They should observe the items, talk about their observation. They will get to know the features of the items this way (name, colour, size).</p>		
<p>Recommendation: Form of work: work individual, with pairs or in group. Aim: development of observation, concept formation, grasping features, negation, labelling, statements, verdicts. We can play it several times. Children often don't capture the properties of the elements in the sentences in the negative. For example: There is none among them which is a dog. At the beginning it is reasonable, but after it lead the children's attention to the attributes of the elements.</p>		

Appendix D

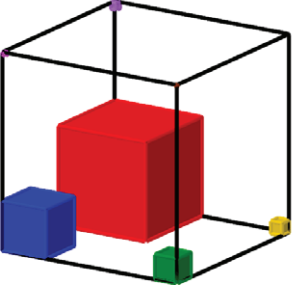
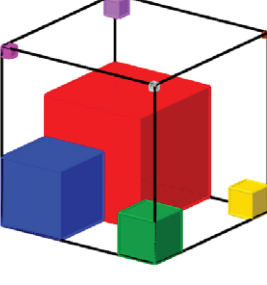
	<p>Grade BC / Age: 10-18 Operation: spatial geometry Sets: Tools more: computer Language: English</p>	<p>TEACHER PUSE Task Number BC 522</p>
<p>Description of the Task: Let's draw a "spatial Poly-Universe" in GeoGebra 3D! Plot a cube, then draw in the vertices of the cube smaller cubes which make up the half, quarter, eighth, sixteenth of the original's sides. In case we draw a "small cube" in each of the vertices by each time halving the edges, what will be the ratio between the edge of smallest cube and of the original cube? Use GeoGebra's "dilate from point" command. Which cube in the line will be "almost invisible"? Let's change the ratio of the similarity! In which of the ratios will the two largest "small cubes" already touch each other? Colour the cubes! How many different colours do we need in order to colour all the "small cubes" as well as the base element differently? How many different cubes would it be possible to colour this way? Take your space vision glasses and switch on space vision in the GeoGebra3D slideshow function!</p>		
<p>Solutions of the Task:</p> <div style="display: flex; justify-content: space-around; align-items: center;">   </div> <p>If the similarity's ratio is 0.5, then (visibly on the left figure) the 7th cube is almost invisible. On the right figure we've determined the ratio so, that the two largest "small cubes" are just touching each other. In this case the similarity's ratio will be $\varphi = \frac{1+\sqrt{5}}{2} \approx 1,618$, i.e. the golden ratio, because according to one of the golden ratio definitions, one segment is to be divided into two so that the ratio of the shorter part and the longer part shall be identical with the ratio of the longer part and the original part. Exactly this has happened here, we've divided the original cube's edge according to the definition of the golden ratio rule. Considering the basic element as well, 9 colours will be needed. This way the result will be $9! = 362\,880$ different colourings. https://www.geogebra.org/m/NS2nks69 https://www.geogebra.org/m/x4hkYxx2 https://www.geogebra.org/m/sVGScaM2</p>		
<p>Recommendation: In GeoGebra, we can create works that can be traced back to the art of Poly-Universe, or interactive applications for editing and rethinking space-geometric elements, such as three-dimensional extensions.</p>		

Contact address:

Eleonóra Stettner
Methodological Institut, Kaposvár University
7400 Kaposvár, Guba Sándor str. 40, Hungary
e-mail: stettner.eleonora@ke.hu

A Poliuniverzum játékcsalád és a matematika oktatás kapcsolata

Stettner Eleonóra

Stettner Eleonóra, Kaposvári Egyetem, Magyarország

Kivonat. A “Poliuniverzum az Iskolai Oktatásban” (Poly-Universe in School Education = PUSE) nemzetközi Erasmus+ projekt célja egy új, vizuális matematikai oktatási módszertan kifejlesztése. A program a Saxon Szász János képzőművész által feltalált Poliuniverzum geometriai éppességfejlesztő játékon alapszik. Az eszköz újdonságértéke az alapformákban rejlő „lépték-váltásos szimmetriában” és az ehhez rendelt színkombinációs rendszerben van. A Poliuniverzum változatos területeken alkalmazható az oktatásban: szerepe lehet például a geometriai és logikai készségek fejlesztésében, vagy a kombinatorikai problémák vizuális megjelenítésében. Az eszköz egyszerűségéből fakadó komplexitásából adódik, hogy több mint játék, több mint művészet, több mint matematika, mert mindezek együttvéve – szinergia az oktatásban.

A projektben négy országból (Finnország, Spanyolország, Szlovákia, Magyarország) vesznek részt tanárok, akik egy feladatgyűjteményt állítanak össze, oktatási módszertant fejlesztenek ki, és ezeket ki is próbálják az iskolai oktatásban. Nagyon érdekes megfigyelni, hogy a különböző országok eltérő oktatási gyakorlata miként tükröződik az egyes országok tanárainak feladataiban, módszereiben.

Az előadásban a projekt eddigi tapasztalatairól, eredményeiről számolok be és néhány érdekes feladatot is bemutatok.

Kulcsszavak: poliuniverzum, matematika oktatás, játékosítás, kombinatorika, szimmetria

The use of mental geometry in the development of the geometric concept of rotation

Nikolina Kovačević

Faculty of Mining, Geology and Petroleum Engineering, Department of Mathematics, Informatics and Descriptive Geometry, University of Zagreb, Croatia

Abstract. One of the most important roles of education is to improve the ability to solve real-life problems. Since a rigid transformation of rotation is one such example in a number of geological situations where structural lines and planes have been rotated from some initial spatial orientation, the notion of rotation takes an important place in the education of geologists. The paper presents the author's teaching experience in developing the concept of rotation as one of the basic geometry concepts within two undergraduate geometry courses in the field of technical sciences at the University of Zagreb.

Combining the principles of classical geometrical representation methods supported by new media, both courses extensively tend to use mental geometry to help students solve many geometric problems that arise from field observations. The aim of the paper is twofold. On the one hand, it presents typical problems that teachers encounter in the teaching of geometry, along with some concrete examples that suggest how problems can be successfully solved by following the latest methodological achievements in modern geometry education supported by mental geometry. On the other hand, the author intends to draw attention to difficulties in the teaching simple geometric concepts that are possibly caused by lack of operational knowledge of geometry of students in the field of technical sciences in Croatia.

Keywords: teaching geometry, mental geometry, spatial geometry, rotation, conceptual knowledge

1. Introduction

The teaching and learning of geometry have changed dramatically over the past two decades under a strong influence of new technology and the social tendency that promote a closer link between mathematical and real-world situations. Firstly, new

artefacts and tools have modified the nature of geometry by changing the methods of construction as well as the use of mathematical concepts. And secondly, they have profoundly altered the cognitive nature of student work, giving a new meaning to visualization and hence changing student's entry into geometry.

The paper presents didactical techniques and principles used by teachers of descriptive geometry in Croatia developed to enhance the undergraduate and graduate geometry courses at the University of Zagreb (GeomTeh3D, 2012). Teaching methodology could be described on the basis of two key ideas from the didactics of mathematics presented in this paper under the headings *Geometric Working Spaces* and *Mental Geometry* (in German: *Kopfgeometrie*). In this paper, the author also describes her own teaching experience in relation to the development of one geometric multifaceted concept dealt with in the mathematics education of future engineers. The author intends to draw attention to difficulties in fostering geometric thinking of prospective engineers. This type of thinking plays an important role in strengthening the perception of mathematics, which is strongly integrated in the engineering world, whether it refers to an educational setting or a real working environment.

Progression in geometry requires first the identification of key geometric entities in the curriculum and then the analysis of geometric work associated with these entities. Key geometric entities are currently still provided through content and content-related learning outcomes used as an orientation to what is expected from the mathematics education of engineers and rotation seems to be one of them (Ragan, 2009; SEFI, 2014). This concept has been chosen for several reasons. It embraces a notion of angle, which is the central notion in various advanced mathematical contexts studied at tertiary level and serves as a basis for the method of revolution, one of the most commonly used methods in many real-life engineering situations where the first steps in the study are largely geometrical. Concern for geometry in relation to rotation in technical engineering education includes the implementations of various methods of projection for recognizing, describing and illustrating the form and orientation of various physical structures and connecting them to mathematical objects, as well as obtaining solutions by using different dimensional aspects of particular structures through the use of various construction techniques (Uttal, 2012). This geometry concept also integrates several important educational geometrical aspects, e.g., angle measurement, orientation, dimension (planar or spatial transformation), multiple concept representations, invariant transformation elements, etc. The last reason comes from the field of cognitive psychology as a geometric transformation of rotation is tightly connected to the ability to mentally rotate objects in space that has been singled out by cognitive scientists as a central metric of spatial reasoning (Barabash, 2017; Bruce and Hawes, 2015).

2. Literature review and theoretical background

At tertiary education level, it is often taken for granted that a student has mastered some basic geometric notions well enough not only to adequately use them and apply them, but also to be able to understand their occurrence relevant to a specific

topic or content. This is, of course, often not the case, and in order to further develop geometrical thinking, teachers are to find and correct erroneously adopted concepts that have already become part of individually adopted working networks of cognitive processes of students (Barabash, 2017; Duval, 2006; Skemp, 1986). This correction process needs to be done on an individual level, and it is a time-consuming process for teachers. Hence, in order to improve the ability to solve real-life problems, the linking bridge between an abstract mathematical concept and a concrete real physical concept should be rebuilt constantly.

One way of rebuilding this bridge is to use spatial geometry and make mathematics more applicable. However, although spatial geometry has been implemented in teaching mathematics in Croatia since the very beginning of education in terms of recognizing and naming basic spatial geometric figures on a visual level, some studies show that, as a branch of mathematics, geometry, especially spatial geometry, is represented very little in schools, mostly only in terms of finding the volume and surface area (Andačić, 2017; Tkalec, 2015; Ursa, 2017). Hence, a discontinuous approach to spatial geometry used in the Croatian curriculum might be the reason why mathematics teachers at tertiary level are facing a long-term absence of discernment of critical features defining geometric figures and their properties, not only of spatial figures but also of planar geometric figures, among students studying at technical universities.

2.1. Theoretical framework of the GWS model

2.1.1. Geometric paradigms

To help both teachers and their educators to understand and implement progression in the teaching and learning of geometry, back in 1999, Cathereine Houdement and Alain Kuzniak introduced the notion of *three geometric paradigms* into the field of didactics of geometry. The paradigms were named simply as Geometry I (GI – Natural Geometry), Geometry II (GII – Natural Axiomatic Geometry) and Geometry III (GIII – Formal Axiomatic Geometry), and they were used to distinguish between two traditionally opposite styles in geometry teaching, i.e., a practical and a theoretical approach. The paradigms are not hierarchically organized, making one of them more advanced than the other, but rather their scopes of work differ and the choice of their problem solving path depends on the purpose of the solver and the paradigm used by the solver. While GI and GII paradigms differ in the validity of mathematical properties and statements as well as the nature of figures, geometry of paradigm GIII breaks any connection to reality and introduces the system of axioms, which is more concerned with logical problems, thus it is used only in teacher training and in advanced mathematics (Houdement and Kuzniak, 2003).

2.1.2. Geometric working space (GWS)

In relation to semiotic, instrumental and discursive processes closely interrelated into geometrical thinking, three paradigms are further implemented with a richer geometric structure called *Geometric Working Spaces* (GWS), whose function is to allow the development of a rich environment for teachers that would enable

students to solve geometry problems in an appropriate way depending on whether the targeted solving paradigm should be GI, GII or GIII. The GWS model also helps teachers understand the circulation of knowledge within specific geometric work, focusing mostly on the organization of various geometric activities. At the moment, this model is part of a more general framework of the *Mathematical Working Space* (MWS) described by Kuzniak and Richard in (Kuzniak and Richard, 2014).

Following the results of various cognitive researchers, the GWS model is structured into two metaphoric planes, i.e., the epistemological and the cognitive plane, and three interacting processes within them called *geneses*. The *epistemological plane* a priori defines expectations of the activity according to the requirements of the mathematical domain, i.e., geometry, through the following three interconnected components:

- i. *representamen* (space and figures) — a real and local space as material support, with one set of concrete and tangible objects such as figures or drawings;
- ii. *artefacts* — a set of artefacts such as drawing instruments or software; and
- iii. *reference* — a theoretical reference system based on definitions and properties.

Similarly, the *cognitive level* is focused on cognitive processes involved in problem solving, which adequately describe corresponding components from the epistemological plane through the process referred to by Kuzniak as *genesis*. Hence, in terms of geometric activity (Duval, 2006), the cognitive plane also consists of three interconnected activity components:

- i. *visualization* — a process of visualization related to the representation of both space and material support;
- ii. *construction* — a process of constructing and applying the instruments (e.g., rulers, compass) and the respective geometrical configuration; and
- ii. *proving* — a discursive process producing arguments and proofs.

The three mentioned *geneses* (or dimensions) are: the *semiotic genesis* (a figural and semiotic genesis that gives the tangible object their status of operational mathematical objects; sometimes it is also referred to as an intuition), the *instrumental genesis* (an instrumental genesis that transforms artefacts into tools within the construction process, which is crucial in the case of geometry), and the *discursive genesis* (a discursive genesis of proof that gives a meaning to the properties used within mathematical reasoning, i.e., deduction). A general diagram of the geometric working spaces is shown in Figure 1. Vertical planes introduced in relation to the *genesis* can be further related to different phases of geometric work implemented in task execution: discovery and exploration in the [sem-ins] plane, justification and reasoning in the [ins-dis] plane, and presentation and communication in the [sem-dis] plane.

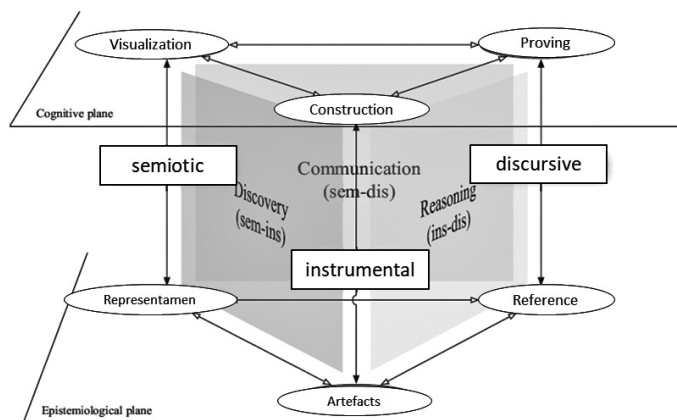

Figure 1. GWS diagram.

A geometric work is considered complete from the GWS viewpoint when an entity is built throughout mutual interaction of all three geneses (semiotic, instrumental and discursive) to achieve the set goal.

The GWS approach provides an organization tool for a more complete insight into the educational processes required in the process of developing multifaceted geometric concepts. For further details, see (Kuzniak and Nechache, 2015; Kuzniak, 2018).

2.2. Mental geometry (in German: Kopfgeometrie¹)

Mental geometry (or *head geometry*) was primarily used by German mathematics didactics as a way of supporting spatial ability in mathematics teaching in secondary education (Hohmann, 2015; Roth, 2011). It refers to the freedom to solve geometry tasks in the head, i.e., without any aids, and it can only be used for ideas and language-based knowledge about geometric objects. Mental geometry tasks contain predominantly visual operation in the imagination based on semiotic representation of concepts. The essential goal of mental geometry is the development of the geometric ability to think and imagine, that is, to think in terms of one, two and three dimensions. The didactical approach that it uses basically includes the following three phases to be run one after another when solving a specific geometry task:

¹German literature distinguishes between two verbally similar didactic approaches used in mathematics education, i.e., *Kopfrechnen* & *Kopfgeometrie*, which are essentially different. The former aims at improving the algorithmic skills trying to automate appropriate numerical skills (such as memorizing the multiplication table or the basic derivation rules), whereas the latter is more focused on the development of the ability to understand rather than to master skills. Since the former, also known as *mental accounting* at an international level, is more famous, and the author did not find any use of the latter outside of the German territory, this paper offers a similar verbal translation of *Kopfgeometrie* on the basis of *mental geometry*, and not based upon a direct English translation (i.e., *head geometry*).

Phase 1: *Verbal task setting* (engaging mental images in a student's head).

Phase 2: *Mental operation* (imagination and mental operation of spatial objects).

Phase 3: *Presentation of results* (presentation, discussion and possible revision of results).

Naturally, not all tasks are applicable to this kind of didactic approach and mental geometry tasks are didactically more oriented towards consolidating recently introduced mathematical concepts in order to establish a stronger mental connection between concept image and concept definition. Mental geometry tasks often aim to break naturally imposed relationships between a concept and concept image (as a simple drawing object). Pure mental geometry focuses on pure verbal-mental interaction without an auxiliary tool used (sometimes a teacher could encourage students to close their eyes in order to foster the imagination process). After that, there follows a phase of a student's individual mental operation and then the solution is verbally reconsidered. It requires the translation of one's own mental visual representation into a verbal expression. Tasks like that are quite challenging, both for students and for a teacher, and they also require a longer period of time for preparation and performance. Unfortunately, they do not always end up successfully. A broader framework for mental geometry is presented in (Hohmann, 2015), allowing a modification of the so-called pure mental geometry tasks (all supporting processes are purely verbal) by introducing some help either to the first or to the third phase. This help could be provided either by teacher's gestures or by using some models, solid networks, objects, drawings, computer programs, etc. Similar aid could be allowed to students in the presentation phase.

Modifications of pure mental geometry tasks could be done to easily fulfill the goals of the variations of geometric curricula created by different roles of geometry in different curricula. Furthermore, emphasis placed on verbal encouragement of the development of mental processes through mental geometry enables us to detect places in the process of education, where lack of clarity leads to confusion or difficulties in learning and understanding of advanced mathematical ideas. This constant verbal communication could also be used to encourage groups of students to interact. For more details on the use of mental geometry, see (Hintze, 2016; Roth, 2011).

Mental geometry tasks have a long history of use in the teaching and learning of descriptive geometry, i.e., the subject closely related to mathematics mostly taught in Croatia at technical faculties and in some secondary technical schools. Descriptive geometry encompasses analysis of 3D objects by means of graphical or mathematical methods applied to 2D images, i.e., it is used as the foundation of engineering graphics by promoting spatial reasoning, training the ability of engineers to express spatial ideas graphically so that they become understandable for anybody else (Kovačević, 2017).

3. Learning example: Transformation of rotation

This section describes the organization of a sequence of activities used as a basis for the development of the geometric concept of rotation in engineering education, where the underlying principles of rotation are used as a basis for the successful application of the method of revolution, i.e., one of the fundamental tools used for solving problems involving space relations. Supporting geometry activities are not focused on one or two teaching units, but rather they are periodically upgraded into two one-term courses (Descriptive Geometry, Descriptive Geometry with Computer Graphics). In the first course, the focus is on solving geometry problems by using accessories (a ruler and compass) in order to strongly encourage the linking of *concept image* and *concept definition* through the corresponding referential component in the epistemological plane. On the other hand, in the second course, students deal with more complex problems and their solving is supported by using professional computer software (in our case, *Rhinoceros* – a commercial 3D application software package). The idea is to focus on the gradual (often long-lasting) development of an applicable mathematical concept of rotation that should be built under the influence of different experience by changing the context in which it appears. Practice has shown that a thorough knowledge of the principles of revolution is vital to problem solving, but in concrete situations it often remains hidden for students.

The first starting point from the GWS point of view is to define what kind of geometric work is at stake, and in this case, it is Geometry II. This is important because sometimes the same task could be solved by means of multiple paradigms (e.g., the distance between two points appears often as a task from primary to tertiary level, changing either the solving methods, the representation form of the included objects; i.e., the same task is approached differently as changes could affect all components of the epistemological plane: representation form, artefacts used and a theoretical frame of reference), so great importance should be placed on the role of language in solving the task that is specific to each paradigm.

Some of the types of activities used in the sequence have already been presented in (Kovačević, 2017). When working on a specific spatial problem in relation to the geometric concept of rotation (e.g., determine the true shape of the cross-section figure, determine the true inclination of an oblique plane, etc.), students are offered ready-made models for work at the beginning of lessons (e.g., handmade basic solid models, solid intersection models or piercing-point models, or a 3D computer program offering virtual model operations) to overcome known didactic problems referring to concepts of planar rotation and angle (Barabash, 2017; Hartmann, 2002; Mitchelmore and White, 2000). Since spatial geometry is a particularly underdeveloped area of current mathematical curricula, problems related thereto are not well studied either (Bruce and Hawes, 2015). Therefore, to cope with further problems related to the development of the geometric concept of rotation, 3D dynamic transformational geometry is used to encourage students to think about how shapes move, change, interact in space, and how to move in relation to shapes and figures. Students are also encouraged, if they want, to build

their own concrete or virtual models. Some support materials made by teachers and students are shown in Figure 2.

Although it is not common to use support models at tertiary level of education, the reason for their use is that the educational experience has shown that many students in Croatia either do not have enough previous experience with real-life tangible objects (that need to be *mathematized* later in the teaching process) or have simply forgotten the basic spatial concepts and their properties due to long time intervals between the units dealing with spatial geometry in the mathematics curriculum in the Republic of Croatia. Hence, a lot of gaps in geometry at tertiary level are revealed that refer to lack of operational knowledge of geometry which should be used as a basis for constructive operation with concepts (gaps were also revealed regarding basic constructions with a ruler and compass in connection with a square, a triangle and a rectangle).

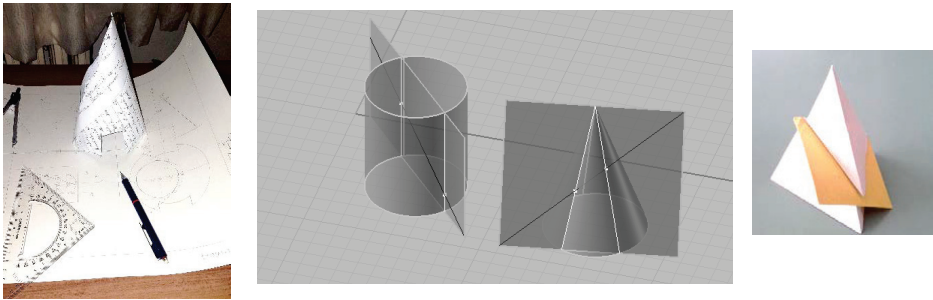
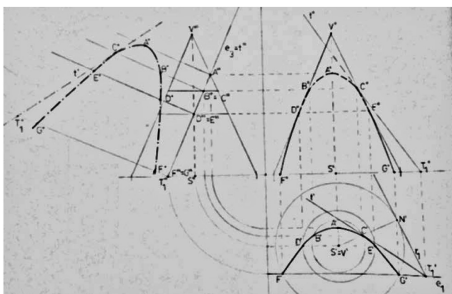

Figure 2. Support material made by teachers and students.

The main objectives of the sequence are to introduce the (spatial) transformation of rotation with an axis and angle of rotation, use its properties to solve various spatial problems (e.g., various measurements: cross-section, surface area, intersection point, angle, etc.), and relate it to constructions with geometric accessories (obtained either by using the ruler and a compass or by means of computer software). The idea is to establish a strong connection with the mathematical transformation of rotation and its use in various spatial problem-solving situations by using the method of revolution. In Figure 3, geometric rotation is used for determining a parabola appearing in its true size and shape.



Task. Intersect a rotating cone with a base in Π_1 , $[S(4, 4, 0), r = 3.5, v = 8]$ with a plane $\Xi(\infty, 5.5, _)$ so that the cross-section is a parabola. Determine its true size and shape and construct a tangent to it.

Figure 3. The use of geometric rotation in a cross-section problem.

Although the GWS framework helps us organize the learning process, at this level of education multifaceted concepts reveal their complexity. Namely, from the GWS point of view, this means that a triplet associated to the rotation concept in the epistemological plane [*sign: rotation, artefact, property: the method of revolution*] is changed when e.g. an artefact is changed as it changes the complete connection process defining a geometric work in relation to a specific geometric concept. Hence, constructions with the ruler and a compass determine one GWS rotation-triplet [*sign: rotation, ruler and compass, property: the method of revolution*] and the construction made by computer software determines the other GWS rotation-triplet [*sign: rotation, computer software, property: the method of revolution*]. Furthermore, in relation to drawings and spatial object representations, changes visible through the visualization process in the cognitive plane (e.g., perspective and parallel views, orthogonal projection, etc.) also affect the overall geometric work associated with the aforementioned GWS rotation triplet.

One may naturally argue about the number of specific geometric entities referring to one concept, depending on the role that the given concept has in the specified curriculum. However, various entities offered by the GWS view could be used to clarify the multifaceted nature that many geometric concepts have. Hence, one may only conclude with the famous Euclidean quote that there is no royal road to geometry.

Let us observe one specific case of completing the geometric work in connection to a GWS rotation triplet, when students become acquainted with the use of the method of revolution in Monge's orthogonal projection, where a ruler and compass are chosen as artefacts, i.e., [*rotation-Monge, ruler and compass, the method of revolution*]. Hence, the goal is to reach to the cognitive construction process used in the method of revolution through the epistemological plane avoiding the use of the *Visualization – Construction* and *Construction – Proving* connections in the cognitive plane. This method of teaching the method of revolution is desirable because it minimizes the permanent influence of changes on the entire geometric work through frequent changes in two epistemological components *Artefact* and *Representamen* resulting from the rapid development of modern technology. Hence, dynamic evolution of the geometric work used during different sessions is shown in Figure 4.

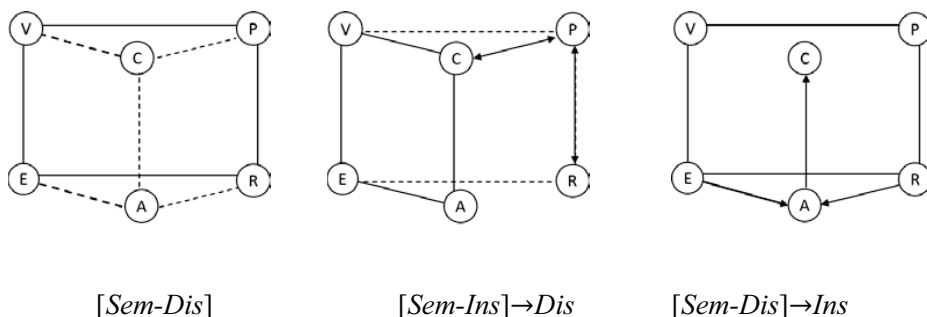

Figure 4. Dynamic evolution of the associated geometric work.

Namely, the identification of the starting geometric work is given by the genesis it implements, which in our case is [*Sem-Dis*], meaning that through communication, the interaction of the semiotic and discursive genesis is encouraged. In descriptive geometry, problem solving is supported with not only semiotic input into the work but also semiotic output. The use of drawing instruments largely depends on prior identification of the characteristic input features, i.e., the ability to “read drawings-figures based on the specific referential frame which in this case is orthogonal projection”. This ability has been supported through communication [*Sem-Dis*] using mental geometry tasks and giving “mathematical sense” to specific drawings by using specific properties of freehand drawings. The aforementioned approach is in contrast to sometimes typical classroom construction sessions, where the instrumental genesis is originally given first, and later the discursive genesis “is inserted” into the whole geometric work. The problem with this traditional approach is that once “the instrumental genesis seems to work” (from students’ perspective), there is no need to add any discursive processes, and any *Reference-Artefacts* or *Construction-Proving* linking connection is disabled.

After demonstrating a constructive process of a point rotating about a line using a compass and a ruler, the construction process is further supported on the cognitive level through the process of proving, i.e., we have [*Sem-Ins*] \rightarrow *Dis*. The discursive genesis is supported by the fact that the basic principles of rotation need to be used to solve a point rotation (e.g., a point rotated about a vertical or a horizontal axis for an angle 90°). Focusing on the rotation given by the axis and angle of rotation, selected examples are chosen not to be uniform and specific in order to break the strong cognitive *Visualization-Construction* connection. A specific metric problem (e.g., determining a cross-section surface area) needs to be used to encourage the establishment of the instrumental genesis through the connection *Referential – Artefacts*. The most general case that involves rotation about an inclined axis for some angle is to be solved only by a computer program. Hence, after solving and discussing two or three tasks together, each student is given his/her own problem/task, which, if needed, can be discussed further with his/her peers or with the teacher. Individual problems and their solutions need to be presented and verbally proved within the given referential framework. The goal is to disable the direct *Visualization – Construction* by fostering a specific problem-solving situation through [*Sem-Dis*] \rightarrow *Ins*.

4. Conclusion

Spatial geometry has entered all levels of education in various forms in all mathematics curricula over the world and someone might even think that the long-lasting problem of many mathematics teachers has finally been overcome at global level (Sinclair and Bruce, 2014), but it is not like that. Problems in terms of the teaching and learning spatial geometry are still huge for many students, and thus also for their teachers (Barabash, 2017; Bruce and Hawes, 2015; Jojo, 2016; Hohmann, 2015; Kovačević, 2017). Many of the problems stem from neglecting an important role visualization and the construction process have in problem-solving situations.

This problem is especially important in Croatia, where many students see geometry as one of the most undesirable branches of mathematics (Šutalo, 2016, p. 36). The reason for that may be the way geometry is taught in Croatia, still purely traditionally, focusing mainly on the planar Euclidean geometry as a basis for deductive reasoning used further in algebra.

However, the descriptive geometry teaching practice has shown that increasing the number of activities in which students handle geometric concepts through the construction process could improve students' understanding and mastering of geometric concepts. Various graphical representations of geometric concepts and properties of methods of projection are the topics that are given a major role in the teaching of descriptive geometry. In addition to being of crucial importance in this era of technology, they might also be used as a broad basis for the direct use of mathematical statements and theorems that are in the traditional mathematical teaching process often either skipped or simply justified only by simple graphic-geometric way or by an indirect use of the notion of congruence (e.g., congruent triangles, congruent transformation, etc.). Traditional access to the use of drawings in a mathematics curriculum often causes significant problems even at lower levels of education, and at higher levels it may be a missing link for adopting various advanced mathematical themes. Also, many difficulties and misconceptions in the usage of multifaceted concepts such as rotation might be avoided, or at least minimized, should the teacher be aware of the way their students have learned the concept in their previous studies.

Solving a mathematical spatial problem often requires first the use of mental rotation skills involving motion of 2D and 3D objects around one or more axes in the mind's eye. However, the development of mental rotation skills is still unsupported by many mathematicians aiming only at mathematical development of the concept of rotation, where students should be able to algebraically manipulate the associated function or matrix transformation form. However, when connecting mathematics to real life, mental rotation plays a crucial role in almost all aspects of spatial geometry.

As for the education of students in the field of technical sciences, it is traditionally full of the use of instant constructive methods that need to be constantly adapted to the use of new artefacts. One way to make their education more effective could be through the *instrumentalisation of mathematical concepts* (such as the geometric concept of rotation) that must be more applicable to problem-solving situations. That could be done by giving new functions to mathematical concepts in order to use them as an instrumental tool in problem solving.

References

- [1] ANDAČIĆ, S. (2017). *Geometrija prostora u srednjoškolskoj nastavi* (unpublished graduate thesis). University of Zagreb, Croatia.
- [2] BARABASH, M. (2017). Angle concept: a high school and tertiary longitudinal perspective to minimize obstacle. In: *Teaching Mathematics and its Applications: An International Journal of the IMA*, 36(1), 31–55.
- [3] BRUCE, D, C. AND HAWES, Z. (2015). The role of 2D and 3D mental rotation in mathematics for young children: what is it? Why does it matter? And what can we do about it? In: *ZDM International Journal on Mathematics Education* (47), 331–343.
- [4] DUVAL, R. (2006). A Cognitive Analysis of Problems of Comprehension in a Learning of Mathematics. *Educational Studies in Mathematics*, 61(1), 103–131.
- [5] GeomTeh3D (2012). *Introducing 3D Modeling into Geometry Education at Technical Colleges*. Fund for Development of University of Zagreb. Retrieved February 2, 2019 from <http://www.grad.hr/geomteh3d/>
- [6] HARTMANN, J. (2002). Schülervorstellungen und Schülerfehler im Bereich Drehung. Eine mehrperspektivische Betrachtung. In: *Zentralblatt für Didaktik der Mathematik*, 34(2), 46–50.
- [7] HINTZE, S. (2016). *Didaktik der Geometrie Kopfgeometrie – Mathematisches Institut*. Retrieved January 20, 2018 from <http://www.math.uni-leipzig.de/~hintze/PraesentationKopfgeometrie/>
- [8] HOHMANN, M. (2015). *Kopfgeometrie zur Förderung des räumlichen Vorstellungsvermögens im Mathematikunterricht in der Sekundarstufe* (unpublished graduate thesis). University Koblenz-Landau, Deutschland.
- [9] HOUEMENT, C. AND KUZNIAK, A. (2003). Elementary geometry split into different geometric paradigms. *Proceedings of CERME*, 3, Bellaria, Italy, 1–9.
- [10] JOJO, Z. M. M. (2016). An exploration of the conceptual understanding of geometric concepts: a case of grade 8 learners in MT Ayliff district. *Proceedings: Towards Effective Teaching and Meaningful Learning in Mathematics, Science and Technology. ISTE International Conference on Mathematics, Science and Technology*, 229–236.
- [11] KOVAČEVIĆ, N. (2017). Spatial reasoning in mathematics. Kolar-Begović, Z., Kolar-Šuper, R. and Jukić Matić, Lj. (Eds.) *Mathematics education as a science and a profession* (pp. 45–64), Element, Zagreb.
- [12] KUZNIAK, A. AND RICHARD, P. R. (2014). Spaces for Mathematical Work: Viewpoints and perspectives. *Revista Latinoamericana de Investigación en Matemática Educativa*, 17(4.1), 7–40.
- [13] KUZNIAK, A. AND NECHACHE, A. (2015). Using the geometric working spaces to plan a coherent teaching of geometry. *CERME 9 – Research in Mathematics Education*, 543–549.
- [14] KUZNIAK, A. (2018). Thinking About the Teaching of Geometry Through the Lens of the Theory of the Geometry Working Spaces. Herbst, P., Cheah, H. U., Richard, P. R. and Jones, K. (Eds.) *International perspectives on the Teaching and Learning Geometry in Secondary Schools: The ICME 13th monographs*, (pp. 5–21) Springer International Publishing AG.

- [15] MITCHELMORE, M. C. & WHITE, P. (2000). Development of angle concepts by progressive abstraction and generalisation. *Educational Studies in Mathematics*, 41, Kluwer Academic Publisher, 209–238.
- [16] RAGAN, D. M. (2009). *Structural geology: An introduction to Geometrical Techniques*. Cambridge University Press.
- [17] ROTH, J. (2011). Geometrie im Kopf. Bewegliches Denken nutzen und fördern. In: *Mathematik Lehren*, 167, 44–47.
- [18] SEFI – European Society for Engineering Education (2013). A Framework for Mathematics Curricula in Engineering Education. *A Report of the Mathematics Working Group* (pp. 1–88). SEFI, Brussels.
- [19] SINCLAIR, N. AND BRUCE, C. D. (coordinators) (2014). Research forum: Spatial reasoning form young learners. In: Nicol, C., Oesterle, S. and Allan, D. (Eds.) *Proceedings of the Joint Meeting of PME 38 and PME-NA*, 36(1), (pp. 173–203). Vancouver, BC: PME.
- [20] SKEMP, R. R. (1986). *The Psychology of Learning and Teaching Mathematics* (2nd ed.). Pelican, 1–32.
- [21] ŠUTALO, Ž. (2016). *Ključne ideje u poučavanju matematike* (unpublished graduate thesis). University of Osijek, Croatia.
- [22] TKALEC, V. (2015). *Kocka i kvadrat kao dio projektne nastave matematike* (unpublished graduate thesis). University of Zagreb, Croatia.
- [23] URSA, A. I. (2017). *Učenje rješavanjem problema na sadržajnom području geometrije* (unpublished graduate thesis). University of Zagreb, Croatia.
- [24] UTTAL, D. H. AND COHEN, C. A. (2012). Spatial thinking and STEM Education: When, Why and How?, In *Psychology of Learning and Motivation*, Vol. 54, Chapter IV (pp. 147–181). Elsevier Inc.

Contact address:

Nikolina Kovačević
Faculty of Mining, Geology and Petroleum Engineering
Department of Mathematics, Informatics and Descriptive Geometry
University of Zagreb, Croatia
e-mail: nkovacev@rgn.hr

Korištenje mentalne geometrije u razvijanju geometrijskog koncepta rotacije

Nikolina Kovačević

Rudarsko-geološko-naftni fakultet, Zavod za matematiku, informatiku i nacrtnu geometriju, Sveučilište u Zagrebu, Hrvatska

Sažetak. Jedna od najvažnijih uloga obrazovanja je poboljšati sposobnosti rješavanja stvarnih problema. Kako je kruta transformacija rotacije jedan takav primjer u brojnim geološkim situacijama gdje se primarne strukture pravaca i ravnina rotiraju iz nekog inicijalnog prostornog položaja, pojam rotacije zauzima istaknuto mjesto u obrazovanju studenata preddiplomskog studija geološkog inženjerstva. Rad predstavlja nastavničko iskustvo u razvijanju koncepta rotacije, jednog od temeljnih geometrijskih koncepata, u okviru dva geometrijska kolegija na preddiplomskoj sveučilišnoj razini studija iz područja tehničkih znanosti na Sveučilištu u Zagrebu.

Kombinirajući principe klasične geometrijske metode reprezentacije potpomognute upotrebom novih medija, oba kolegija u velikoj mjeri koriste mentalnu geometriju kako bi pomogla studentima u rješavanju geometrijskih problema koji proizlaze iz promatranja na terenu. Namjera ovog rada je dvojaka. S jedne strane, prikazani su tipični problemi s kojima se susreću nastavnici pri poučavanju geometrijskih sadržaja, kao i neki konkretni primjeri koji upućuju na to kako se problemi mogu uspješno riješiti slijedeći najnovija metodološka dostignuća u suvremenoj metodici nastave matematike kroz primjenu mentalne geometrije. S druge strane, autor namjerava skrenuti pozornost na poteškoće u podučavanju nekih jednostavnih geometrijskih koncepata koje su vjerojatno uzrokovane nedovoljnom razinom operativnog znanja studenata iz područja tehničkih znanosti u Hrvatskoj.

Ključne riječi: poučavanje geometrije, mentalna geometrija, geometrija prostora, rotacija, konceptualno znanje

From “calculation in mind” till “mental calculation”

Maja Cindrić¹, Irena Mišurac Zorica² and Josipa Jurić²

¹Department of Teacher and Preschool Teacher Education, University of Zadar, Croatia

²Faculty of Philosophy, University of Split, Croatia

Abstract. Through the history of mathematics teaching in the territory of Croatia, there have been many changes, one of them being linked to the approach, attitudes and even the very name of what we call today mental calculation. Mental calculation bridge of conceptual and procedural mathematical knowledge and derives from activities at the very beginning of mathematics learning. Depending on the time and needs of society and the economy, consequences of certain educational reforms and quantitative indicators at the regional and global level attitudes toward mental calculation as part of math teaching have changed. Attitudes are often equated with the use of algorithms in written calculations, which is marginalized within mathematics teaching, either because of the over-utilized use of procedural methods of a written calculation, or because of the emphasis on problem solving mathematical tasks for the development of conceptual knowledge.

This paper will give a historical overview of the approach to a mental calculation by analyzing mostly textbooks for teaching mathematics in the territory of today Republic of Croatia as well as the term used for these purposes.

Keywords: mental calculation, calculation in mind, oral calculation

1. Introduction

Calculation is an indispensable part of mathematics teaching, but there is often confusion in understanding the need and the purpose of calculating as an element of mathematical knowledge. Considering the purposefulness and the need for calculating in the teaching mathematics, we can proceed from the following assumptions that affect the quality and importance of calculating in teaching mathematics:

- Traditional teaching mathematics, especially in lower grades of primary school, emphasizes calculating as the backbone of mathematics as a subject, whose focus is on the result of the calculation, and less on the processes leading to that result.
- Availability and widespread use of computer tools enables each person to quickly and accurately determine the outcome of some calculation, which reduces the usability of calculating as a daily life requirement.
- Relatively low achievements of Croatian pupils on external evaluations of mathematical knowledge in the focus of methodical discussions result in problem solving and their emphasis contrary to calculating. Stressing one element of teaching, in this case problem solving, in teaching practice can lead to neglecting another element, in this case calculating.

These assumptions can lead to the wrong interpretation of the requirements for mathematical education and the negation of the importance of calculating in teaching mathematics. On the other hand, the recent literature in the Croatian language and the legal acts that determine the teaching mathematics in primary schools are insufficiently clear about what calculation assumes, which forms of calculating lead to quality mathematical knowledge and what steps and to what extent is it necessary to implement calculating in teaching pupils, and which goals and requirements to set. In particular, here we want to emphasize the calculation in mind and the forms of its emergence through the history of teaching mathematics in schools in the territory of today Republic of Croatia, and by analyzing the textbook and methodological literature to clarify the potential loss and transformation of mathematics goals over time as well as the use of different terms for these purposes.

2. Forms of calculating in teaching mathematics

The basics of calculating are, first and foremost, the factual knowledge of calculations, which are often referred to as addition tables and multiplication tables, which imply memorization and placement in long-lasting memory the results of addition and subtraction numbers up to 20, and multiplying and dividing numbers up to 10 in the same way. We do not neglect the process of acquiring this knowledge at the required level, from the understanding of the arithmetic calculation concept to the concept of natural numbers and zero itself, activities in concrete situations and with concrete materials, to the use of the properties of arithmetic operations and their interconnection.

Calculation, according to the process of getting the result, can be grouped into mental calculation, calculating by writing procedures or written calculation and computer calculation (Musser, 2008; van de Walle, 2008).

Mental calculation is the process of performing an arithmetic calculation without the help of a calculator or any external recording equipment (Reys, 1985).

The theory of mental calculation assumes the use of many mathematical knowledge, conceptual knowledge of numbers and number system, arithmetic calculation properties, arithmetic calculation correlation, ability to evaluate results, advanced personal and taught calculating strategies. Mental calculation is a useful and purposeful part of learning mathematics if the pupil manages to efficiently, accurately and flexibly link all of the abovementioned elements of mathematical knowledge (Principles and Standards for School Mathematics, 2000). Then we speak of the fluency of mental calculation. Achieving fluency in calculating is the minimum outcome of learning mathematics, as it does not only mean knowledge of calculation, but integration of different parts of mathematics (Russell, 1999). Understanding mathematical concepts without the fluency of mental calculation and a written calculation prevents the process of problem solving, while only practicing written calculation without understanding mathematical concepts and fluency in mental calculation leads to frequent errors in the calculation itself, and the pupils are not able to make a step toward problem solving tasks. Fluency in calculation during lower grades of primary school is a strong predictor of future successful learning of mathematics (Gersten, 2005).

3. Forms of calculation in curriculums for teaching mathematics through history in the Republic of Croatia

Legislation that regulates teaching in general, including teaching mathematics, have had different names through history, from curriculum, through program structures for primary schools, catalogs of knowledge and curriculum for primary school again to the curriculum for mathematics for primary and secondary schools in the Republic of Croatia. These documents describe, to a lesser or greater extent, what calculation in teaching mathematics means and at what level pupils need to adopt it.

Curriculum for primary school in the Republic of Croatia in 1946 points out that the task of teaching calculation is to introduce pupils to numbers and number relations in the nature and society. In the first and second grades, addition, adding, subtraction and factoring the numbers up to 100 are taught, as well as multiplication, measuring, and division up to 100. In this document it is emphasized that *“all these operations are performed only verbally”* and once again at the end of the second grade it is pointed that *“confident verbal solving tasks in all four arithmetic calculation operations up to 100”* is what a pupil has to know at the end of the second grade. Further, in the third grade all four arithmetic calculation operations up to 1000 are mentioned, first verbally, and then in writing, and finally in the fourth grade, the same statement for numbers up to 1,000,000 *“first verbally and then in writing”*.

A document titled: *“Primary School. Program Structure”* of 1958 reduces the gradation of the arithmetic calculation operations introducing procedure and does not mention addition, adding, factoring and measuring as a way to four calculation operations, but merely refers to addition, subtraction, multiplication and division, both oral and written. Another interesting news in this document is a statement

that requires a teacher to write the oral addition and subtraction. Although it is not explicitly written what is considered to mean – to write an oral calculation, it is assumed that this is a practice that is still used today in teaching mathematics, which is the working out of calculation from left-to-right using the separation of the second addend, such as $26 + 38 = 26 + 30 + 8 = 56 + 8 = 64$.

The document “*Our Primary School: Educational Structure*” of 1972 starts reforming the teaching mathematics in schools, based on the effort to “*modernize and intensify learning mathematics and to integrate in it those contents that are the result of contemporary teaching mathematics development*”. The foundation upon which this reform was based came from *New Mathematics* reform in the United States, and its emphasis was on *introducing greater demands to pupils which lead them to mathematical concepts, structure, symbols and terms used in mathematical science*. Since at this point the focus was on mathematics as a scientific discipline, calculation is not mentioned anywhere in this document, but calculation operations that need to be worked out with listed operations’ properties in a set of natural numbers with zero, *so that pupils can understand the terms of a group, group and field (without naming)*. The methodological approach to calculation, as well as other elements of teaching mathematics, is omitted in this document.

During the eighties of the 20th century, followed the curriculums of primary education that continue the writing style of the 1972 document, although they amortized in content the attempt of 1970s reform to introduce the structure of mathematics science in teaching from the first grade of primary school. However, indications of what kind of calculation is expected that the pupils know in each particular grade, are omitted.

Further, the documents that legally govern the primary school teaching practice include the contents of individual grades with short descriptions in the introductory part and highlighting the objectives of teaching mathematics and assignments for pupils which are general for all grades. This style of writing continues with the 2006 *Nastavni plan i program za osnovnu školu* [Primary School Curriculum], where along with the teaching content are introduced the educational achievements, but it is not clear how the pupils need to calculate, but only stated that pupils need “*to master the addition process (subtraction, multiplication, division ...*” in the first and second grade of primary school, while in the third and fourth grade as a topic stands out “*Written addition and subtraction (multiplication, division)...*”, and in the educational outcome there stands “*to master written addition (subtraction, multiplication, division) ...*”.

And finally, the document that regulates teaching mathematics in the Republic of Croatia, on the part of content and pupils’ achievements, the Curriculum for Mathematics for Primary and Secondary Schools in the Republic of Croatia introduces the concept of *mental calculation*. Development of the A.2.3. *Pupil adds and subtracts in a set of natural numbers up to 100* outcome states that a student at the end of the second grade *will mentally add up and subtract in a set of numbers up to 100*. The fact that after a long time in the legal document stands out the form of calculation that is expected to be performed by pupils in the second grade is not the news, but just a written teaching practice that has been going on for years,

even from the time it was called an *oral calculation*. However, the news provided by this document, which was not a practice, is in the third grade where the A.3.2. *Pupil adds and subtracts in a set of natural numbers up to 1000* outcome development states that a student at the end of the third grade *will mentally add up and subtract numbers up to 1000*, but also *add up and subtract in writing by applying the appropriate mathematical written record*. It is interesting to note that the same outcomes development model is not applied to multiplication and division, where is only stated that a pupil *multiplies and divides within the multiplication table* in the second grade, and in the third grade, *multiplies and divides in written numbers up to 1000 by one-digit number*, so it can be concluded that multiplication and division in no part of it should be done in one's head, but in writing, not even for multiplication and division by 10, 100 and 1000.

4. Forms of calculations in textbooks for teaching mathematics through history in the Republic of Croatia

Although legal regulation is an important guideline and in this case an indicator of the method of teaching in mathematics, many studies have shown that the influence of teaching practice is largely in the textbooks but in the legal acts, so we will also look at the textbook literature which gives us a deeper insight into the development of the forms of calculation through history in the territory of today's Republic of Croatia and the development of the concept in which mental calculation developed and how the name of the term influenced the change of purpose and meaning of mental calculation.

Mate Zoričić, author of one of the first books in Croatian language dealing with calculation – *Aritmetika u slavni jezik illiricki* [Arithmetic in glorious language of Illyrian], states in the introduction that the reason for writing the textbook in Croatian language, the teaching of calculation for Croatian people, that foreign merchants could not deceive them anymore and make themselves rich from the misery and ignorance of Croatian peoples. At about a hundred pages, Zoričić gradually explains the basics of calculation operations in Croatian, pointing out what the reader has to know “*by heart, and can always calculate*” by thinking of a written calculation. For our consideration is the significant use of the term “*by heart*”.

While Zoričić aims his lines to everyone, Nikola Hacxich (1854) in his „*Rac-sun iz glave*“ [Calculating in head], addresses a teacher who will teach the pupil how to calculate, and already at the very beginning emphasizes to the reader “as soon as pupils start attending classes, they need to start learning how to calculate in their heads”. Learning mathematics by Hacxich is divided into ten steps through which he gradually gives instructions to teachers. Following Hacxich's steps, it is clear how much emphasis was put on teaching calculation at that time on mental calculation, which is entirely clear considering the time when Hacxich lived. Although the objective of teaching calculations of that time is not explicitly expressed and we may doubt whether it was closely related to the needs of society to educate individuals willing to work or their objective is deeper, related to mathematics as a scientific discipline, Hacxich in each step starts from mathematical bases, so in the

second step before introducing of addition he says “*The basis in each comparing of numbers is one. So the duty of each teacher is to prove to his/her pupils that numbers are composed from number one.*” There are no many methodological instructions in the book such as this one, but there are all the calculations that need to be learned, such as: “*2 and 1 unit make how many units? 3 and 1 unit make how many units?.. 2 and 2 units make how many units?.. 2 is greater than 1 for 1 unit*”. In teaching calculation of that time, there were no signs: plus, minus, times and division, neither were used terms like addition, subtracting, multiplying and division, but were written calculation sentences and was made the difference between operations that we know today to determine the arithmetic calculation operations. So was *multiplication* separately taught (*3 and 1 unit make now many units?*), and *comparison* as well – *what is greater and for how many*. Methodical approach to teaching calculation by Haxich is also seen in the instruction “*Pupils need to be taught to analyze the tenths and units that compose the numbers made of multiples tenths and units*” and “*pupils need to be orally tested by randomly chosen calculations.*” From this last point it is clear that teaching calculation does not just mean mere learning by heart, but the calculation had to be learned with understanding so testing pupils by randomly chosen calculations would be successful. In this paper there is a possible reason for the future name of this form of calculation as “oral calculation” that was introduced by Cuvaj in 1904. It is clear that oral testing requires an oral answer, especially as it was a time when it was not possible for pupils to write on paper.

Klaić in his “Initial Calculation textbook or Systematic Calculation by heart Training” continues Haxich’s style of oral testing of calculations by numerous questions. This textbook in more details leads teachers in calculation teaching by gradually describing the steps of calculating acquiring from counting to questions and tasks that cover the entire spectrum of situations that determine single calculation operations, such as the following questions:

“*Which number is for 1 smaller than 9?*”

“*For how many is 10 greater than 1?*”

“*From which number do I have to subtract 1 to get 5?*”

“*How many coins can I spend out from 4 if I want to keep 1 coin?*”

“*You have 10 apples, your brother has 8 apples. For how many does your brother have less than you? For how many do you have more than your brother?*”

As mentioned earlier in 1908, Cuvaj for the first time introduces, in his textbook *Računica* [Calculating] : *for the 1st year of lower public school in Croatia and Slavonia*, the concept of oral calculating by suggesting in his introductory tasks the left-to-right calculation method, which is still used as a synonym for oral calculating. In this textbook, there are fewer questions than in Klaić’s textbook, and by its form it is more like today’s textbooks, with numerous calculating tasks and several textual tasks. And then, there appeared the signs: plus and equals in textbooks. Other textbooks throughout the time till nowadays follow the same writing style and division of calculation tasks into orally calculated and those calculated by a *written* procedure. Unlike nowadays, when oral calculating is performed only in the second grade with numbers up to 100, textbooks up to the seventies demanded

an oral calculating with numbers up to 1,000 and even one million as well as oral calculating of some multiplication calculations.

5. Conclusion

The term of *mental calculation* describes best the objective to be achieved by learning calculating in mathematics classes. Mental procedures that a person applies trying to determine the solution are more important than the results themselves, especially in today's availability of computer technology. Mental operations, knowledge linking, applying strategies, efficiently, accurately and quickly is the benefit from calculating. The term *by heart, in head* that has been used since Hacxich, judging by the concept of tasks and instructions, presupposes mental calculation, which is the very name of the book saying "from head". The present opportunities and methodological procedures that point to the often questioning of calculating and verbalization led to the concept of *oral calculation*, which is still used today. Mental operation that a person performs when calculating can be organized into several categories, such as left-to-right method, calculating with compatible numbers, addition and multiplication compensations, the use of calculating operations properties, calculation results with compatible numbers and special factors such as 10 and its exponents (Musser, 2008). In addition to the common mental algorithms, the person that calculate can also use personal strategies that combine the standard ones. Each person uses the calculation methods in a unique manner and organizes it according to one's own capabilities and needs (Plunkeett, 1978). Nevertheless, since 1908 textbooks suggest a left-to-right method, while in Klaić's (1863) textbooks is also used the joining of tenths and ones method. The left-to-right method is an effective way of mental calculating, as opposed to the concept of a written procedure. However, the frequency of using the written procedure puts aside the left-to-right method. Current teaching practices use the left-to-right method for addition and subtraction up to 100 in the second grade of primary school, and in higher grades only written calculation algorithms making mental calculating completely neglected. Using left-to-right method in teaching practice is called oral calculation, which, by tracing the historical development of the term, refers to mental calculation, but the use of the left-to-right method does not mean at the same time mental calculating procedures. Today, unlike the Hacxich's era, pupils are available to write down, so it is often seen that all ideas of calculating *by heart, in head, mental or oral*, are reduced on working out the calculation by the left-to-right method what is contrary to the definition of a mental calculation.

References

- [1] CUVAJ, A. (1908). *Računica: za I. godište nižih pučkih škola u Hrvatskoj i Slavoniji*. Nakladom Kr. hrv.-slav.-dalm. zemaljske vlade.
- [2] GERSTEN, R., JORDAN, N. C., FLOJO, J. R. (2005). Early indication and intervention for students with mathematics difficulties. *Journal of learning disabilities*, 38.

- [3] HACXICH, N. (1834). *Racsun iz glave : za ucsitelje i ucsenike narodnji shkola u Slavoniji / sastavi i na svit izdade Nikola Hacxich, upravitelj sviju Ces. Kralj. nimacski i ostali narodnji shkola u Slavonsko-Srimskoj Kraini.*
- [4] KLAJIĆ, F. (1863). *Početna računica ili sustavna obuka u računstvu na pamet.*
- [5] (2019). *Kurikulum za nastavni predmet matematika za osnovne škole i gimnazije u Republici Hrvatskoj.*
- [6] MOČNIK, F. (1884). *Prva računica za pučke učione.* U C. kr. nakladi školskih knjiga, Beč.
- [7] MUSSER, G. L., BURGER W. F., PETERSON, B. E. (2008). *Mathematics for Elementary Teachers.* Wiley.
- [8] (2006). *Nastavni plan i program za osnovnu školu.*
- [9] (1946). *Nastavni plan i program: za narodne četverogodišnje i šestogodišnje škole i niže razrede osmogodišnjih škola u Narodnoj Republici Hrvatskoj.*
- [10] MUHVIĆ, Z. (Ed.) (1972). *Naša osnovna škola: odgojno-obrazovna struktura.* Školske novine, Zagreb.
- [11] (1958). *Osnovna škola. Programska struktura.* Školske novine, Zagreb.
- [12] The National Council of Teachers of Mathematics (2000). *Principles and Standards for School Mathematics.*
- [13] REYS, R. E. (1985). Mental computation skills. *Arithmetic Teacher*, 33.
- [14] RUSSELL, S. J., SMITH D. A., STOREYGARD J., MURRAY M. (1999). *Relearning to Teach Arithmetic: Multiplication and Division*, Dale Seymour Publications, N.J.
- [15] VAN DE WALLE, J. KARP, K. S., BAY-WILLIAMS, J. M. (2008). *Elementary and Middle School Mathematics-Teaching developmentally*, Pearson.
- [16] ZORIČIĆ, M. (1766). *Aritmetika u slavni jezik illiricki.* Gradska knjižnica "Juraj Šižgorić", 1995, Šibenik.

Contact addresses:

Maja Cindrić
Department of Teacher and Preschool Teacher Education, University of Zadar
Franje Tuđmana 24i, Zadar, Croatia
e-mail: mcindric@unizd.hr

Irena Mišurac Zorica
Faculty of Philosophy, University of Split
Poljička cesta 35, Split, Croatia
e-mail: irenavz@ffst.hr

Josipa Jurić
Faculty of Philosophy, University of Split
Poljička cesta 35, Split, Croatia
e-mail: jjuric@ffst.hr

Od “računa napamet” do “misaonog računanja”

Maja Cindrić¹, Irena Mišurac² i Josipa Jurić²

¹ Odjel za izobrazbu učitelja i odgojitelja Sveučilišta u Zadru, Hrvatska

² Filozofski fakultet u Splitu, Sveučilište u Splitu, Hrvatska

Sažetak. Kroz povijest nastave matematike na području Hrvatske dolazilo je do mnogih promjena, a jedna od njih veže se i za pristup, stavove, pa i sam naziv onoga što danas zovemo misaonim računom. Misaono računanje spona je konceptualnog i proceduralnog matematičkog znanja, a potječe od aktivnosti u samim počecima učenja matematike. Ovisno o vremenu i potrebama društva i gospodarstva, posljedicama određenih odgojno obrazovnih reformi i kvantitativnim pokazateljima na regionalnoj i globalnoj razini mijenjali su se stavovi prema potrebi računanja kao dijelu nastave matematike. Stavovi su često izjednačavali primjenu algoritama u računanju s misaonim računom, koji je u okviru nastave matematike marginaliziran, bilo zbog prenaplašene upotrebe proceduralnih metoda pisanog računa, bilo zbog nastojanja da se za razvoj konceptualnog znanja naglasak stavi na problemske matematičke zadatke.

Ovaj rad će dati povijesni pregled pristupu misaonom računu analizom većinom udžbeničke literature za nastavu matematikena teritoriju današnje Republike Hrvatske, kao i nazivlju koji je korišten u te svrhe.

Ključne riječi: račun napamet, usmeni račun, misaoni račun, mentalni račun, aritmetika

2.

Fostering geometric thinking

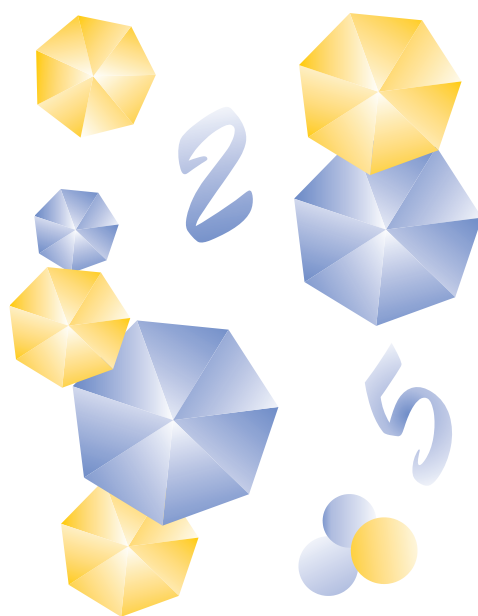

From a nice tiling to theory and applications

Emil Molnár, István Prok and Jenő Szirmai

Department of Geometry, Institute of Mathematics, Budapest University of Technology and Economics, Budapest, Hungary

Dedicated to the Memory of Professor Stanko Bilinski (1909 – 1998).

Abstract. Starting with the fundamental tiling for the Euclidean plane group **16.p6** with pentagons, we see that any tile – after “logical” side pairing (as gluing) – will be a surface (now a topological sphere, realized by a doubly covered triangle, of angles $90^\circ = \pi/2$, $60^\circ = \pi/3$, $30^\circ = \pi/6$) with singular points (as above by periods 2, 3, 6, respectively) as rotational centres with angles $180^\circ = \pi$, $120^\circ = 2\pi/3$, $60^\circ = \pi/3$ (imagine with colours: green, blue, red), respectively.

Consider this for the 17 plane groups of Euclidean plane \mathbf{E}^2 , then for the analogous groups of sphere \mathbf{S}^2 (where the angle sum of any triangle bigger than $180^\circ = \pi$; we have infinitely many groups, but finitely many types), moreover for the analogous groups of the Bolyai-Lobachevsky hyperbolic plane \mathbf{H}^2 (where the angle sum of any triangle smaller than π ; infinitely many groups, but we shall have an overview by the so called Macbeath signature).

And so on, going to the classical theory, relatively completed for dimensions 2 in our joint work (Lučić et al., 2018) on so-called Poincaré–Delone (Delaunay) problem, and its nice applications in science and arts. The very hard analogous 3-dimensional topic will also be mentioned, mainly with examples and figures only.

Our aim is also to give an *Honour to the Memory of Professor Stanko Bilinski*, a scientific Father of former Yugoslavian and Hungarian geometricians, who was a “master of Brezelfläche” (double torus) and its hyperbolic tilings, see e.g. in (Bilinski, 1985).

Keywords: crystallographic groups in \mathbf{E}^2 , \mathbf{S}^2 , \mathbf{H}^2 , Poincaré–Delaunay problem of “planigons”

1. Introduction

In our Fig. 1 (below, imagine its colours) there is a *mosaic* or *tiling* with *fundamental pentagons* in Euclidean plane \mathbb{E}^2 . You can notice the hexagonal α -rotations by their red 6-centres and $2\pi/6$ angles, and similarly the blue 3-centres (β) and the green 2-centres (γ). There are also *translations* by a hexagonal lattice of the 6-centres. For any two pentagons there is a unique *transformation*, mapping the first pentagon onto the second one, and the whole plane tiling onto itself. All together these transforms, mapping an (arbitrarily distinguished) yellow *identity domain* ($\mathbf{1} = I$) onto any *g-domain*, constitute the *plane group* $G = \mathbf{p6} = 236$ ($g \in G$) by the composition operation. Thus, we have pictured the above group G (given also by the other internationally accepted notation): Any *path* from the *identity* (I) through adjacent domains to *domain g*, expresses g with the *generators* α, β, γ (and their *inverses* $\alpha^{-1}, \beta^{-1}, \gamma^{-1} = \gamma$, try it, please, not easy!). So we can imagine also the *group-graph* for G with *three types of (coloured) directed edges*, according to the three generators.

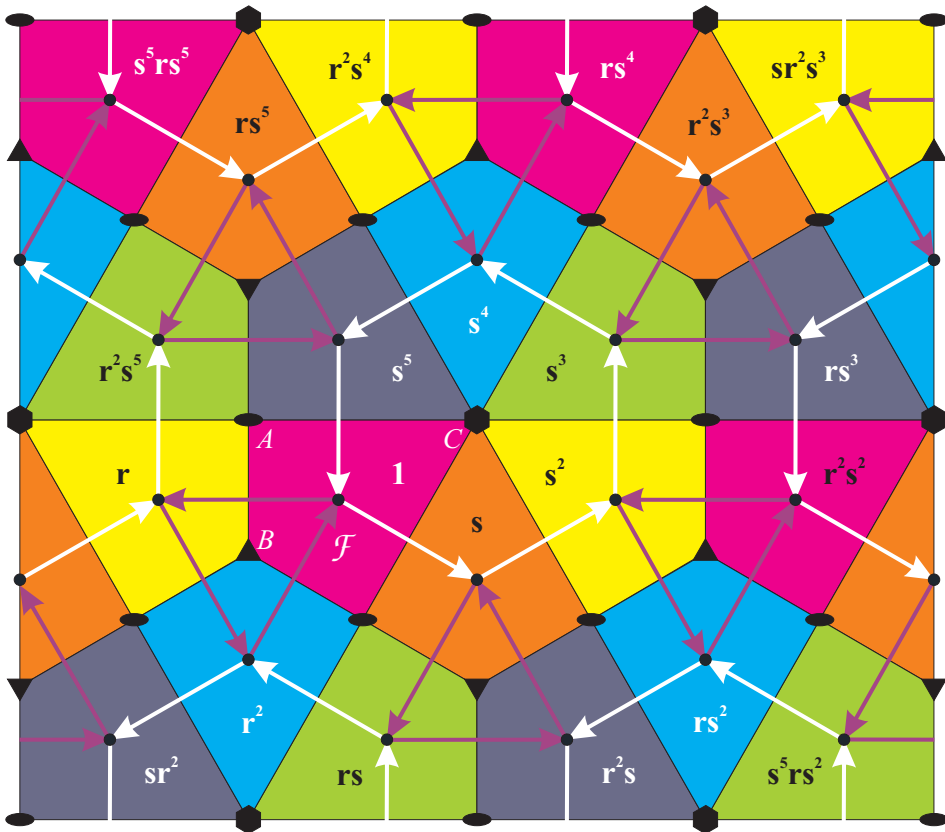

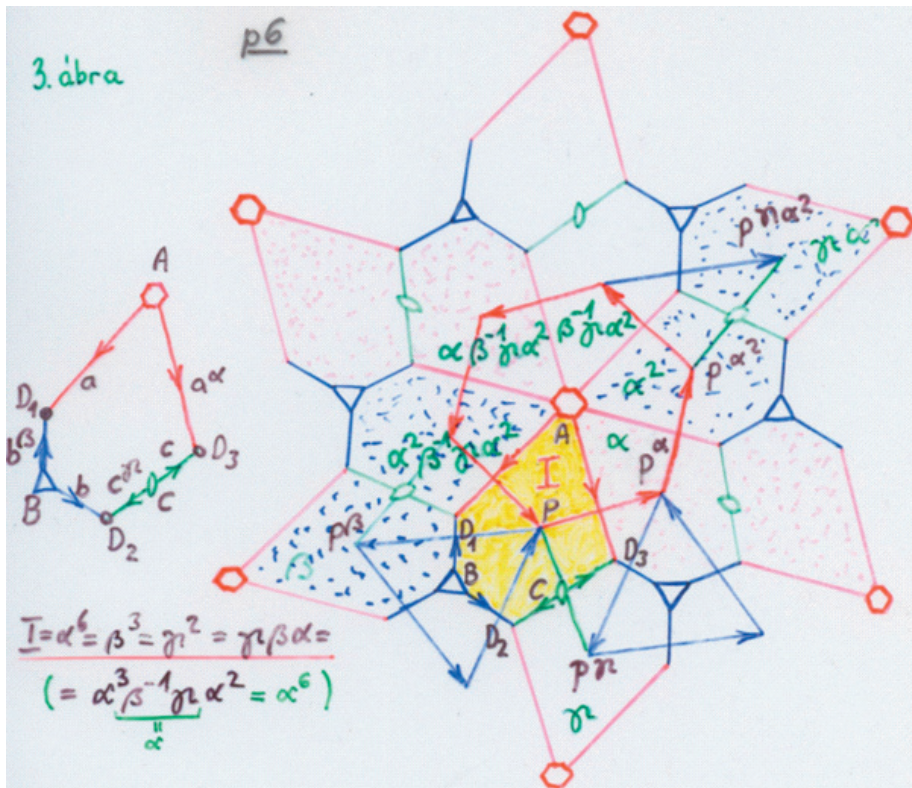

Figure 1. The Euclidean plane group **16.p6** and its fundamental pentagon tiling. Generating side pairs: red for 6-rotation α , blue for 3-rotation β , green for 2-rotation γ , are also indicated. The introductory (6-coloured) picture shows other interesting phenomena, study them please!

You can imagine that the complete group theory can be interpreted in such a geometric language, and this visualization has many benefits, e.g. for attractive geometric problems.

For instance, the above group **p6** = 236 can have 4 (*topological!*) types of fundamental domains (find all polygon types intuitively first, please!) Our school ruler (linear) with angles $\pi/2, \pi/3, \pi/6$ helps a lot. The analogous groups 234, 235, each has also 4 types but in the sphere S^2 ; 237, 238, ... have also 4 types, but in the Bolyai-Lobachevsky plane H^2 . Our school ruler ($45^\circ, 45^\circ, 90^\circ$) helps in finding all the 3 types of fundamental domains for the Euclidean plane group $G = 244 = \mathbf{p4}$.

In Euclidean plane E^2 there are 17 analogous plane groups (as a genial intuitive discovery of the medieval Islamic art, e.g. the Alhambra in Granada, Spain). The Hungarian György (George) Pólya also dealt with them. All the 46 topological types of their fundamental domains (and also the 47 non-fundamental ones) had completely been found only in 1959 by B. N. Delone (Delaunay). H. Poincaré in 1882 had already attempted to describe the analogous plane groups in H^2 , by con-

structuring a new model for it in complex number field \mathbf{C} and by fundamental domains in it for these plane groups (it turned out later, that this attempt was hopeless).

To find a unified method for all possible types of (compact) fundamental domains for all plane groups in \mathbf{S}^2 , \mathbf{E}^2 , \mathbf{H}^2 , this *Poincaré-Delaunay planigon problem* has been remained open for a long time. This will be our topic now. *The basic concepts are also not easy!*

Your late Professor Stanko Bilinski, at the University of Zagreb, worked a lot with hyperbolic plane groups and their realizations. His favourite (e.g.) was the double torus (“Brezelfläche” in his nice German presentations, (Bilinski, 1985)).

Other compact surfaces with higher genera g [orientable (+) with g tori or handle bodies (handles), indicated by \circ ; or not (–) with g *projective planes or cross caps*, indicated by \times (or also by \otimes)] come into considerations as well. They can also have l occasional singular points as rotational centres, with given periods

$$2 \leq h_1 \leq h_2 \leq h_3 \dots \leq h_l \quad (1.1)$$

as rotational orders. Furthermore, q boundary components can come into the play (after $*$'s) with given dihedral corners (of group orders $2h_{ij}$; l_i corners on the i -th component, in Fig. 9 we use also $l \rightarrow m$, $l_i = 0$ is also possible):

$$*h_{11}, \dots, h_{1l_1} * \dots * h_{q1}, \dots, h_{ql_q}; \quad 2 \leq h_{ij}$$

with corner angle

$$\pi/h_{ij}; \quad 1 \leq i \leq q, \quad 1 \leq j \leq l_i \quad (1.2)$$

for line reflections. All these are up to an *equivariance* (*geometric or topological orbifold equivalence*) have to be cleared later on. These lead to the *Macbeath signature* (or, equivalently, to the shorter *orbifold notation of J. Conway*, as we use above and later on):

$$\circ \circ \dots \circ h_1, \dots, h_1 * h_{11}, \dots, h_{1l_1} * \dots * h_{q1}, \dots, h_{ql_q} \times \times \dots \times \quad (1.3)$$

either with g initial circles \circ (for tori or handles), or g final crosses \times (for projective planes or cross caps). The absence of circles and crosses means that the base manifold M of the above orbifold \tilde{M} is a sphere. The above *equivariance of groups* (induced by a topological mapping) leads to the criteria that rotational centres and boundary components can arbitrarily be permuted. Dihedral corners in a boundary components are determined up to a cyclic permutation in the orientable case, where all components are considered according to the given orientation, or all components are opposite. For a non-orientable orbifold on its any boundary component, cyclic and reverse-cyclic permutation lead to equivariant cases, i.e., a topological mapping maps one orbifold onto the other, preserving the group action. A “milestone” was in 1967 the

Theorem of A. M. Macbeath. *The above signature by (1.3) guarantees the equivariance of orbifolds or plane groups.*

The so-called “bad” orbifolds cause some extra phenomena yet (see Proposition 5.1).

Description of a fundamental polygon is not easy, too, but the cyclic enumeration of vertices and sides helps us. E.g. in Fig. 1 the pentagon can be described by $a6Ab3Bc2C$; here $a6A$ means: the paired sides a and A are oppositely directed and divided by the 6-centre. 2-centre here is not a vertex, but a side midpoint(!). Trivial stabilizer at a vertex is not signed by number. Other conventions you can find out. E.g. $2a6A2b3B$ is a quadrangle fundamental domain for $p6 = 236$ (Fig. 1). $3a6A3b2B$ and $6a3A6b2B$ are two triangle fundamental domains. All these are up to cyclic or reverse-cyclic ordering and occasional changing the letters.

The “final” step seems to be solved by *Program COMCLASS*, and the summarizing joint paper with Zoran Lučić and Nebojša Vasiljević has been published in (Lučić et al., 2018).

We shall indicate the very hard analogous 3-dimensional topics as well in Section 6, mainly with “nice” examples and figures only, see (Molnár, 1992, 1997), (Prok, 2018), (Szirmai, 2007), (Molnár et al., 2006, 2017), (Molnár and Szirmai, 2018, 2019), (Stojanović, 2017) where we have – almost exclusively – “only” open problems, in general. Some Euclidean problems have been solved, “because of their crystallographic importance”.

2. Tori (handles) and projective planes (cross caps) with figures

The first plane group $\mathbf{1.p1} = \circ$ is illustrated in Fig. 2 with a rectangle fundamental domain, where the opposite sides are identified by translations \mathbf{e}_1 and \mathbf{e}_2 (corresponding arrows also indicate them), respectively. With rectangle we can glue the first opposite side pair to a cylinder, but further we cannot glue the opposite circles! (or it is still possible!). In topology we allow elastic paper, so we can imagine that arbitrary parallelogram $ABCD$ realizes the torus by gluing $AB \leftrightarrow DC$, $AD \leftrightarrow BC$.

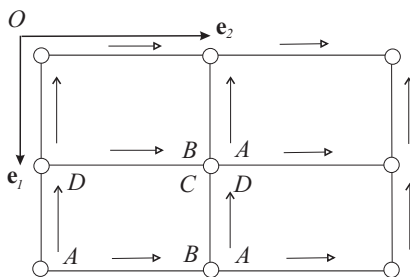

Figure 2. The topological torus and the plane group $\mathbf{1.p1} = \circ$, generated by two translations \mathbf{e}_1 and \mathbf{e}_2 identifying the opposite sides of the parallelogram $ABCD$ (now a rectangular one, by logical gluing, try to realize it with paper disc).

This can be with Euclidean metric as indicated above, or without any metric, i.e. topologically. Since any Euclidean parallelogram can be mapped onto another one by an affine transform (one-to-one mapping Euclidean plane onto itself, preserving point-line incidences), we say that the plane group $\mathbf{1} = \mathbf{p1}$ (and

its fundamental parallelogram) is determined up to *affine equivariance*. But “any usual” quadrangle with “identified opposite sides” define a *torus*. With the “ signs we indicated that this “tiresome definition” is still not complete yet!

Torus, cut out with a (small) disc (with boundary circle, also for later gluing up), is called also handle body or simply handle. Two handles glued together along the boundary circles yield the double torus as mentioned previously and Fig. 7. A sphere glued with g handle bodies will be illustrated in Fig. 8 as a general orientable compact surface.

The simplest non-orientable compact surface is the *projective plane* in Fig. 3, also as the (“digon”) fundamental domain of the plane group of sphere S^2 , consisting of two elements: the identity $\mathbf{1}$ and the point reflection (or inversion) $\bar{\mathbf{1}}$ in the sphere centre O . Projective plane cut out with a (small) disc is called also cross cap. Two or more cross caps can be glued to a sphere along boundary circles to get the general typical non orientable surface which consists of g cross caps (Fig. 4 illustrates them), but also with other interpretations depending on g .

The cutting-gluing and “regluing” procedures (called *making connected sums*) are typical in topology. We only mention a nice

Theorem 2.1. *The connected sum of a torus and a projective plane is topologically the same as the connected sum of 3 projective planes.*

Consequence 2.2. *A non-orientable surface is exactly that contains a cross cap at least.*

So we can leave out here the very important (but delicate) equivalent definitions of non-orientable (or one-sided) and orientable (two-sided) surfaces.

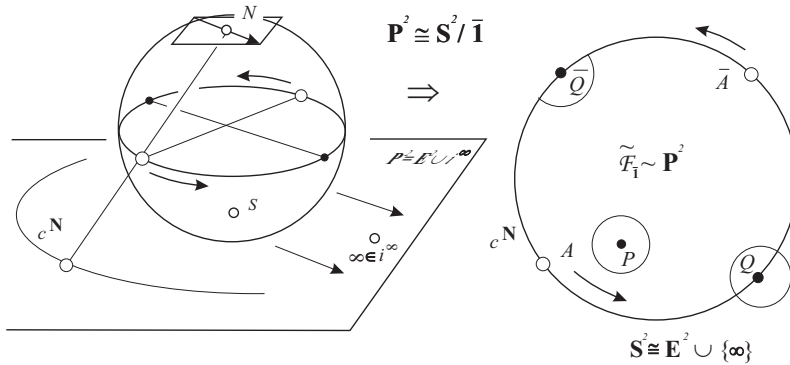

Figure 3. The projective plane \mathbf{P}^2 ($\times = \mathbf{1}$), derived from the sphere by identifying its opposite points (reflected in the sphere centre O). Then we can project the south half sphere either from the north pole N into the plane touching the sphere in the south pole S , to obtain the fundamental domain $F_1 = \mathbf{P}^2$: the circle disc with glued opposite circle points. Or project the same one from the sphere centre O onto projective plane $\mathbf{E}^2 \cup i^\infty = \mathbf{P}^2$ as usual.

The connected sum of two projective planes (cross caps by second picture of Fig. 3) can be realized in the usual plane \mathbf{E}^2 , as follows in Fig. 4, by the Klein

bottle, also with its rhombic fundamental domain.

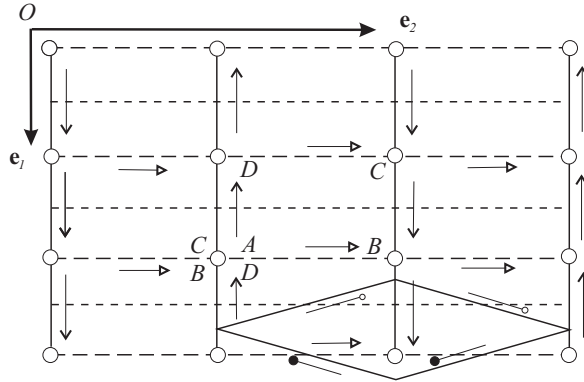

Figure 4. The Klein bottle and $4.pg = \times \times$, as a glued rectangle ($abAb$, see the arrows), again with $AB \leftrightarrow DC$, but $AD \leftrightarrow CB$. This last step can be realized in space only by self-intersection. You see in right bottom corner another gluing, as connected sum of two projective planes with rhombic fundamental domain $aabb$ with equivalent vertices and side pairs $\text{---}\circ, \text{---}\bullet$.

3. Vector models (projective models) for later computations

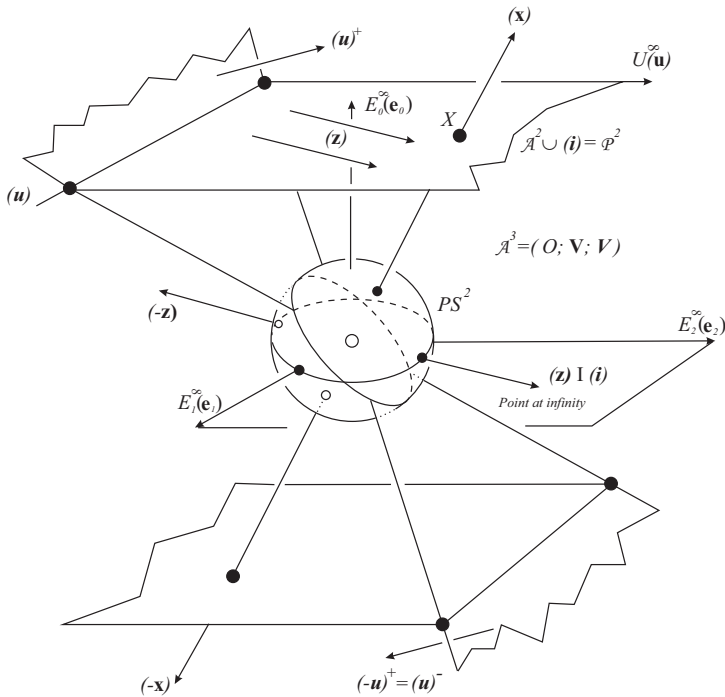

Figure 5. The vector model V^3 of projective sphere PS^2 , affine and projective plane are also in the picture (compare with Fig. 3).

We illustrate only some 3-dimensional pictures for 2-dimensional, i.e. plane situation, although we do not use this machinery (imagine also d -dimensional situations modelled in $d + 1$ -vector spaces, in Fig. 5). Sphere \mathbf{S}^2 and hyperbolic plane \mathbf{H}^2 are extremely important, although we have to restrict ourselves on few words. We only hint to popular introductory literature. The projective Beltrami-Cayley-Klein (B-C-K) circle model (in Euclidean sense) of hyperbolic plane \mathbf{H}^2 is illustrated in Fig. 6 that will be indicated also with curved lines and deformed angles, etc., without any exact model. See Fig. 7, where the regular octagon has $2\pi/8 = 45^\circ$ angles, equal arrows hint to the congruent hyperbolic transform that carries each signed side into the corresponding one. Every point of this fundamental octagon has a disc-like neighbourhood (in hyperbolic metric), so does the double torus (not in the embedding Euclidean space, of course). Please, use your phantasy also later on!

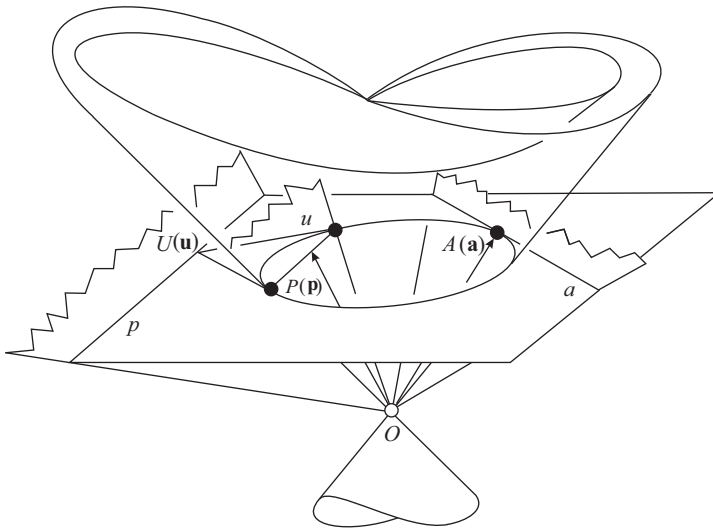

Figure 6. Hyperbolic plane \mathbf{H}^2 and $\mathbf{H}^2 \times \mathbf{R}$ space in vector model ($\mathbf{H}^2 \times \mathbf{R}$ is in another sense: each cone half lines through origin O illustrate the direct component real number-line \mathbf{R} , zero level is \mathbf{H}^2).

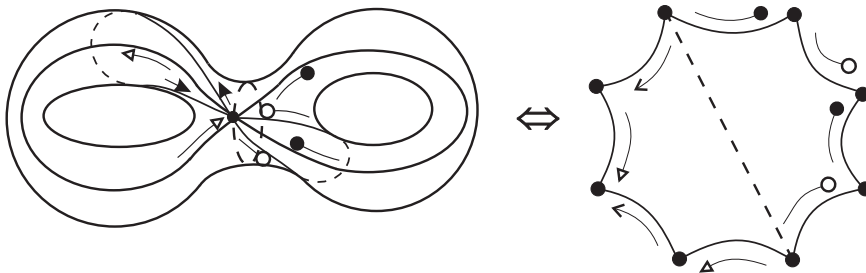

Figure 7. The double torus and its unfolding onto a regular hyperbolic octagon of angles $2\pi/8 = 45^\circ$ (compare with Fig. 8).

4. Plane groups and orbifolds, symbolic pictures only for orientable cases

We glue g handles for an orientable surface, although this can already be realized with many fundamental polygons (of super-exponential complexity by g). Fig. 8–9 illustrate the general

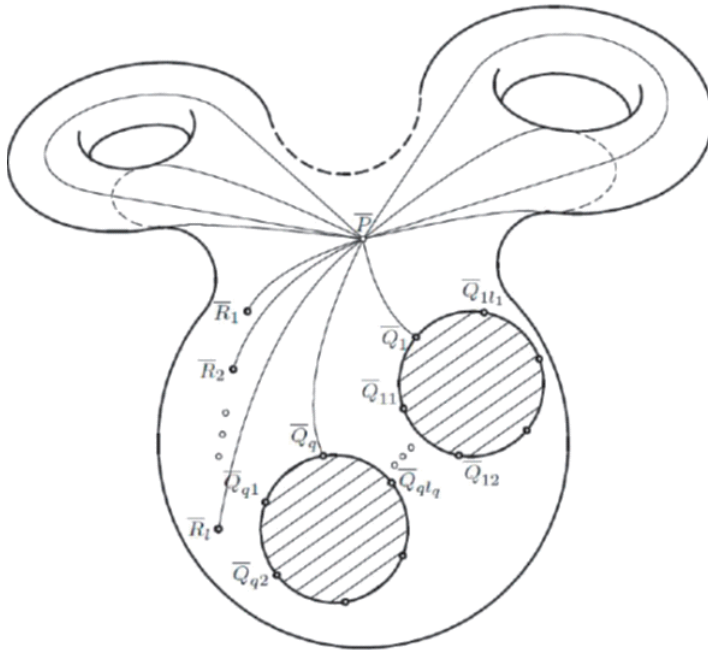

Figure 8. A symbolic orientable surface with g handles, l rotation centres (also $l \rightarrow m$ in Fig. 9), q boundary components (occasional dihedral corners on them). Point \bar{P} is for unfolding with $2\alpha g$ arcs for tori and projective planes (now $\alpha = 2$ for g handles; else $\alpha = 1$ for g cross caps), $2l$ arcs for l rotational centres, $2q$ connecting arcs for q boundary components; plus $l_i + 1$ unpaired arcs (here) for the i -th component $1 \leq i \leq q$.

Strategy 4.1. For possible fundamental polygons of a plane group G or orbifold we consider on its surface a (symbolic) disc, containing all the rotation centres, the boundary components (first each is compressed into a vertex) and x additional points (with trivial stabilizer, their number will be restricted later). Moreover, on the boundary of the disc we consider $2\alpha g$ ends for unfolding arcs, see Fig. 8–9, also for orientable and (not pictured) non-orientable cases.

Then we have to construct a tree graph (of super-exponential complexity) to these vertices, where the valence (degree) of each additional vertex is at least 3. Then we “unfold” the surface along this tree graph, as with a “usual scissor” to get a topological “plane disc”, but think of some “metric conditions” (with later \mathbf{E}^2 , \mathbf{S}^2 , \mathbf{H}^2 metrics by Proposition 5.1), too. A scissor arc will make a side pair of the fundamental polygon with corresponding directions. The copies of an additional

point will produce the angle sum 2π . The copies of a rotation centre yields an angle sum $2\pi/h_i$ ($1 \leq i \leq m$). Then each boundary component, that was a vertex first, will be reformed to a boundary circle for unpaired sides with occasional dihedral corners on them of angle sum π/h_{ij} ($1 \leq i \leq q, 1 \leq j \leq m_i$).

Then among all polygons we select the combinatorially different ones.

The next Fig. 9 also illustrates the strategy, in Fig. 10 we see a maximal and a minimal tree graph for unfolding the same orbifold.

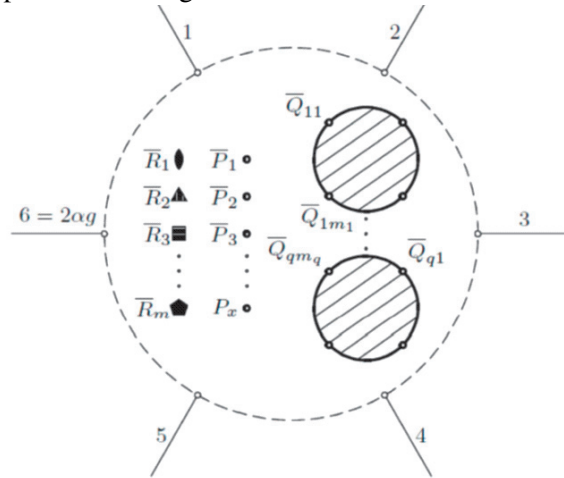

Figure 9. A symbolic picture for the surface diagram of an orbifold for its future tree graphs and its future unfolding onto fundamental domains (see also Fig. 8).

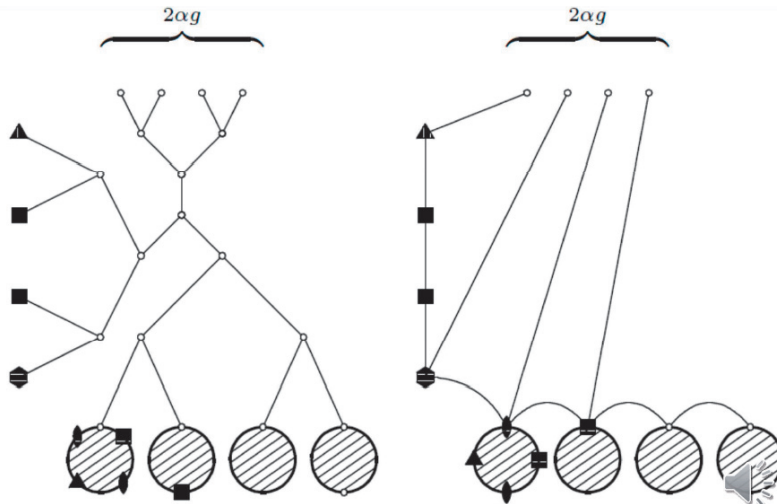

Figure 10. Two tree graphs: a maximal one (left, with additional vertices for the tree graph) and a minimal one (right) for the same orbifold (or plane group) and unfolding. It can be orientable ($\alpha = 2, g = 1$) or non-orientable ($\alpha = 1, g = 2$).

5. Propositions for our algorithm strategy, some illustrations

Our very abstract subject gives us a lot of possibilities to make nice “Escher-like” pictures in Euclidean plane E^2 , sphere S^2 and hyperbolic plane H^2 as well. But how to recognize them? The answer is also a very nice (formerly known) mathematical statement:

Proposition 5.1. (curvature formula) *The orbifold or plane group of signature (1.3) can be realized on sphere S^2 , in Euclidean plane E^2 and in hyperbolic plane H^2 , if*

$$\begin{array}{l}
 > & H^2 \\
 0 = & 4 - 2\alpha g - 2 \sum_{i=1}^l (1 - 1/h_i) - 2q - \sum_{j=1}^q [\sum_{k=1}^{l_j} (1 - 1/h_{jk})] & E^2, \\
 < & S^2
 \end{array} \quad (5.1)$$

respectively. Exceptions are 4 types of “bad (spherical) orbifolds” with signatures:

$$u \text{ and } *u \text{ for } 2 \leq u; \text{ furthermore } u, v \text{ and } *u, v \text{ for } 2 \leq u < v. \quad (5.2)$$

The arguments are “simple”: the corresponding angle sum of a fundamental polygon has to be bigger, equal or less than the Euclidean one. The spherical exceptions occur, because opposite points of sphere shall have the same stabilizer subgroup of symmetry.

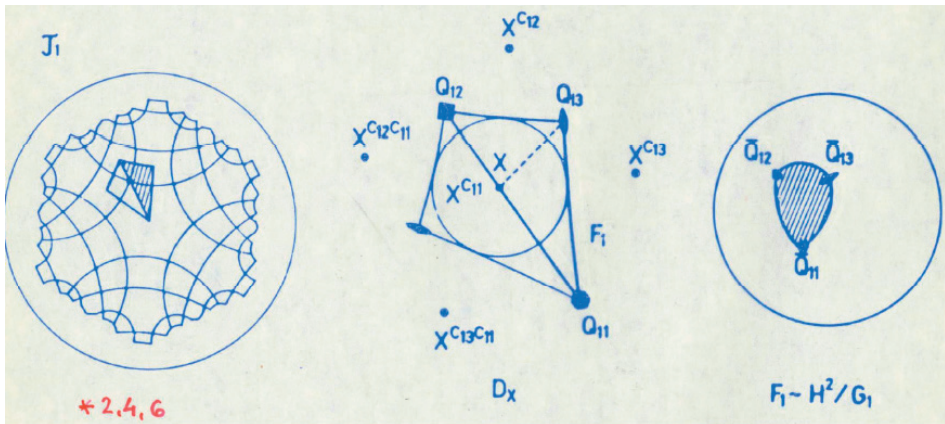

Figure 11a. Archimedean tiling T_1 with vertex symbol $\{4, 4, 4, 6\}$; group or orbifold symbol is $*246$ (non-fundamental or multiple tiling).

Proposition 5.2. *For the number x of additional points of an orbifold tree (Fig. 9) holds*

$$x \leq 2\alpha g + l + q - 2. \quad (5.3)$$

Open problem: *What is the maximal radius of this inscribed circle for a given group (orbifold)? Analogous (more difficult) questions arise for minimal circumscribed circle.*

Figures 10–11 call the attention to these and other problems. Fig. 11 shows the dual of fundamental tiling, in particular the Archimedean one, where regular polygons surround a vertex. A surprising fact that Archimedean tilings with the same vertex-symbol can have different symmetry groups in hyperbolic plane \mathbf{H}^2 . Inscribed circles into fundamental polygons can be seen in Fig. 11a-b.

We have further complication to our algorithm: different tree graphs can yield the same fundamental domain.

The *Program COMCLASS* of Nebojša Vasiljević can treat these difficulties in on-line mode, of course for simpler signatures because of the complexity (Lučić at al., 2018).

6. An infinite series of hyperbolic space forms and other analogies

Consider the previous topic in 3 dimensions! Of course, we only indicate these much more difficult problems only with some examples and figures. The 3-dimensional torus (Fig. 12) is completely analogous to Fig. 2. In space \mathbf{E}^3 we have 230 space groups (in 219 affine classes, 11 isomorphic pairs differ only by left-right orientation). All fundamental polyhedra (stereohedra) are known only for some groups of them. A polyhedron algorithm for determining them has been “described” (in a principle form) in (Molnár, 1992), implemented by István Prok [see a report in (Prok, 2018)], again with super-exponential complexity.

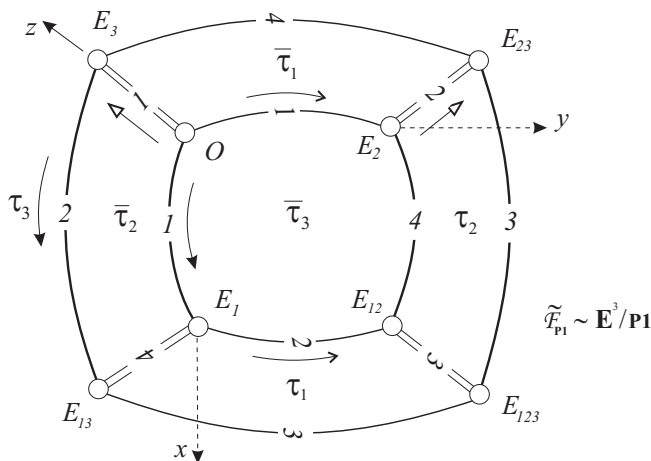

Figure 12. The 3-dimensional torus as a brick in Euclidean space \mathbf{E}^3 (in Schlegel diagram) by identifying (gluing) its opposite side faces by 3 translations τ_1, τ_2, τ_3 . 4 parallel edges will be in one equivalence class (we get 3 classes). The 8 vertices also form an equivalence class. So any point will have a ball-like neighbourhood.

In hyperbolic space \mathbf{H}^3 we are far from a classification of space groups. There are some complete results for hyperbolic simplex fundamental domains and truncated simplex domains (Molnár at al., 2006) and in recent or ongoing works of Milica Stojanović, e.g. (Stojanović, 2017). The Coxeter-Schläfli orthoschemes (Fig. 13) and their relatives seem to be important in \mathbf{H}^3 for extremal ball packing and covering problems and manifold constructions. Applications come into considerations, as fullerenes and nanotubes, simply in non-Euclidean crystallography, see e.g. in (Molnár at al., 2017), (Molnár and Szirmai, 2018, 2019).

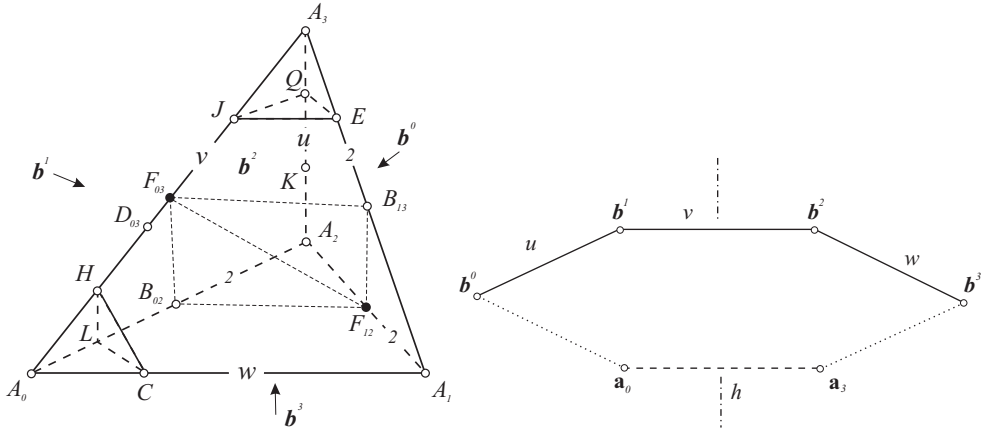

Figure 13. The hyperbolic doubly truncated orthoscheme $W(\beta^{01} = \pi/u, \beta^{12} = \pi/v, \beta^{23} = \pi/w)$ and its extended Coxeter-Schläfli diagram (right) with $\pi/u + \pi/v < 1/2$, and $\pi/v + \pi/w < 1/2$ and its half-turn symmetric version for $u = w$. In particular $u = v = w = 2z, 3 \leq z$ odd leads to our cobweb (tube) manifold series $Cw(2z)$, glued together the 4 u copies of half W around Q , so that every point of $Cw(2z)$ has a hyperbolic ball-like neighbourhood.

The above orthoscheme $O = W$ will also be a projective simplex coordinate system $A_0A_1A_2A_3 = b^0b^1b^2b^3$ in projective 3-space $\mathbf{P}^3(\mathbf{V}^4, \mathbf{V}_4, \sim)$, analogous to Fig. 5 with corresponding vector space basis $A_i \leftrightarrow \{\mathbf{a}_i\}, \mathbf{a}_i \in \mathbf{V}^4$; and dual basis $b^j \leftrightarrow \{\mathbf{b}^j\}, \mathbf{b}^j \in \mathbf{V}_4$ with Kronecker symbol $\mathbf{a}_i \mathbf{b}^j = \delta_i^j (i, j \in \{0, 1, 2, 3\})$. The angles β^{ij} between simplex side faces b^i and b^j will be defined by the Coxeter-Schläfli cosine matrix $(\cos(\pi - \beta^{ij})) = (b^{ij})$ as follows

$$(b^{ij}) = \langle \mathbf{b}^i, \mathbf{b}^j \rangle := \begin{pmatrix} 1 & -\cos \frac{\pi}{u} & 0 & 0 \\ -\cos \frac{\pi}{u} & 1 & -\cos \frac{\pi}{v} & 0 \\ 0 & -\cos \frac{\pi}{v} & 1 & -\cos \frac{\pi}{w} \\ 0 & 0 & -\cos \frac{\pi}{w} & 1 \end{pmatrix} \quad (6.1)$$

Then the angle metric can be defined in general. Moreover, the distance metric between points will be defined by the inverse matrix

$$(a_{ij}) = (b^{ij})^{-1} = \langle \mathbf{a}_i, \mathbf{a}_j \rangle$$

$$:= \frac{1}{B} \begin{pmatrix} \sin^2 \frac{\pi}{w} - \cos^2 \frac{\pi}{v} & \cos \frac{\pi}{u} \sin^2 \frac{\pi}{w} & \cos \frac{\pi}{u} \cos \frac{\pi}{v} & \cos \frac{\pi}{u} \cos \frac{\pi}{v} \cos \frac{\pi}{w} \\ \cos \frac{\pi}{u} \sin^2 \frac{\pi}{w} & \sin^2 \frac{\pi}{w} & \cos \frac{\pi}{v} & \cos \frac{\pi}{w} \cos \frac{\pi}{v} \\ \cos \frac{\pi}{u} \cos \frac{\pi}{v} & \cos \frac{\pi}{v} & \sin^2 \frac{\pi}{u} & \cos \frac{\pi}{w} \sin^2 \frac{\pi}{u} \\ \cos \frac{\pi}{u} \cos \frac{\pi}{v} \cos \frac{\pi}{w} & \cos \frac{\pi}{w} \cos \frac{\pi}{v} & \cos \frac{\pi}{w} \sin^2 \frac{\pi}{u} & \sin^2 \frac{\pi}{u} - \cos^2 \frac{\pi}{v} \end{pmatrix}$$

where

$$B = \det(b^{ij}) = \sin^2 \frac{\pi}{u} \sin^2 \frac{\pi}{w} - \cos^2 \frac{\pi}{v} < 0,$$

i.e.,

$$\sin \frac{\pi}{u} \sin \frac{\pi}{w} - \cos \frac{\pi}{v} < 0. \tag{6.2}$$

First, the distance of simplex vertices will be defined by $\cosh(A_i A_j) = -a_{ij} / \sqrt{a_{ii} a_{jj}}$, then distance for any two points $X = x^i \mathbf{a}_i$ and $Y = y^j \mathbf{a}_j$, as usual. Much deeper is the volume formula of an orthoscheme and especially of a complete orthoscheme by the following

Theorem 6.1. (R. Kellerhals by the ideas of N. I. Lobachevsky) *The volume of a three-dimensional hyperbolic complete orthoscheme $O = W_{uvw} \subset H^3$ is expressed with the essential angles $\beta^{01} = \frac{\pi}{u}$, $\beta^{12} = \frac{\pi}{v}$, $\beta^{23} = \frac{\pi}{w}$, ($0 \leq \beta^{ij} \leq \frac{\pi}{2}$) (Fig. 13) in the following form:*

$$\text{Vol}(O) = \frac{1}{4} \left\{ L(\beta^{01} + \theta) - L(\beta^{01} - \theta) + L\left(\frac{\pi}{2} + \beta^{12} - \theta\right) \right. \\ \left. + L\left(\frac{\pi}{2} - \beta^{12} - \theta\right) + L(\beta^{23} + \theta) - L(\beta^{23} - \theta) + 2L\left(\frac{\pi}{2} - \theta\right) \right\}$$

where $\theta \in [0, \frac{\pi}{2})$ is defined by

$$\tan(\theta) = \frac{\sqrt{\cos^2(\beta^{12}) - \sin^2(\beta^{01}) \sin^2(\beta^{23})}}{\cos \tilde{\text{S}}(\beta^{01}) \cos \tilde{\text{S}}(\beta^{23})} \tag{6.3}$$

and where $L(x) := -\int_0^x \log |2 \sin(t)|$ denotes the Lobachevsky function (in J. Milnor's interpretation).

The volume $\text{Vol}(B(R))$ of a ball $B(R)$ of radius R can be computed by the classical formula of János Bolyai:

$$\text{Vol}(B(R)) = 2\pi(\cosh(R) \sinh(R) - R) = \pi(\sinh(2R) - 2R) \\ = \frac{4}{3} \pi R^3 \left(1 + \frac{1}{5} R^2 + \frac{2}{105} R^4 + \dots \right). \tag{6.4}$$

We note here that in (Molnár and Szirmai, 2018)) we studied the packing and covering problems in \mathbf{H}^3 with classical congruent balls. We considered periodic ball arrangements related to the truncated, so-called complete Coxeter orthoschemes and their extended groups (see Fig. 13). We formulated two theorems and conjectures for the densest ball packing with density 0.77147, and for the loosest ball

covering with density 1.36893, respectively. The metric data are summarized in the following two shortened tables:

Table 1.s.i.a, Packing, $O = As, \frac{1}{u} + \frac{1}{v} > \frac{1}{2}, \frac{1}{v} + \frac{1}{w} \geq \frac{1}{2}$				
(u, v, w)	r^{opt}	$\text{Vol}(W_{uvw})$	$\text{Vol}(B(r^{opt}))$	δ^{opt}
(5, 3, 5)	0.95142	0.09333	4.31988	0.77147
(3, 5, 3)	0.69129	0.03905	1.52220	0.64967

Table 1.s.i.a, Covering, $O = As, \frac{1}{u} + \frac{1}{v} \geq \frac{1}{2}, \frac{1}{v} + \frac{1}{w} > \frac{1}{2}$				
(u, v, w)	R^{opt}	$\text{Vol}(W_{uvw})$	$\text{Vol}(B(R^{opt}))$	Δ^{opt}
(5, 3, 5)	1.12484	0.09333	7.66539	1.36893
(3, 5, 3)	0.89558	0.03905	3.53002	1.50661

You can imagine that these computations (with computer, of course) can be carried out for our cobweb (tube) polyhedra (glued together from copies of the above half orthoschemes) in the following as well. These results are under publications, we described them in (Molnár and Szirmai, 2018, 2019).

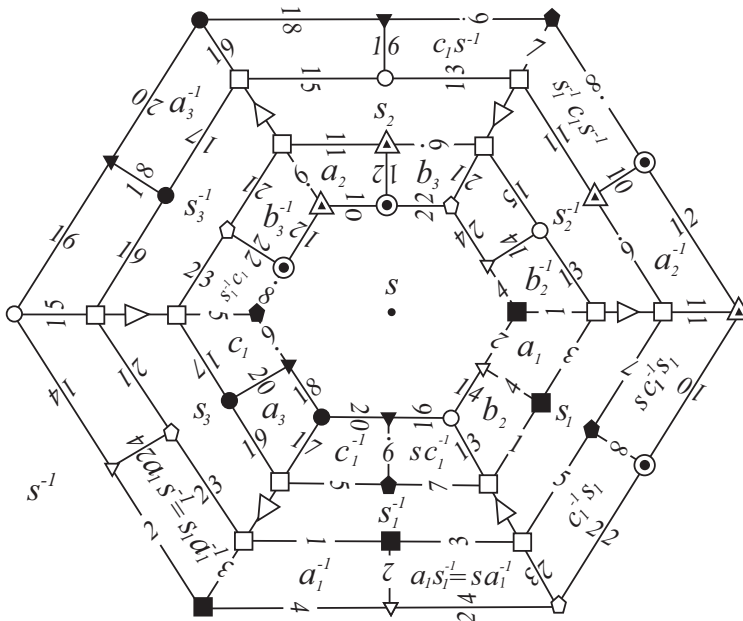

Figure 14. The symbolic polyhedral picture of the cobweb (or tube) manifold $Cw(2z = 6)$, or in general, for parameter $z = 4p - 1$. Equally indicated side faces (e.g. the bases s^{-1} and s) and edges are glued together to form a hyperbolic manifold (for nanotube applications).

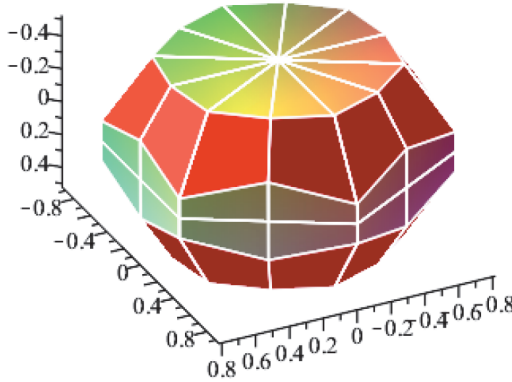

Figure 15. Our cobweb manifold $Cw(2z = 6)$ has also a (simplified) tube realization in \mathbf{H}^3 , think of gluing the copies along the previous base faces s^{-1} and s to form an infinite tube.

We have proved the following theorems, see (Molnár and Szirmai, 2019):

Theorem 6.1. *The cobweb (tube) manifold $Cw(2z = 6)$ to cobweb polyhedron as fundamental domain has been constructed by the given face pairing identification in Fig. 14, 15 by rotational symmetry of order three.*

Theorem 6.2. *The cobweb (tube) manifold series $Cw(2z = 8p - 2)$, $2 \leq p \in \mathbf{N}$, for any cobweb polyhedron as z -cyclic fundamental domain has been algorithmically constructed. The cobweb polyhedron $Cw(2z)$ is built up from the half complete orthoscheme $O = W(2z)$ by gluing its $8z$ copies around its vertex Q as a new centre in Fig. 13.*

The bases s^{-1} and s of this domain are paired by the screw motion $\mathbf{s} : s^{-1} \rightarrow s$ of rotational angle $2\pi(z-1)/(2z)$. The further face pairing is generated by $z = 4p - 1$ screw motions $a_i : a_i^{-1} \rightarrow a_i$. The fundamental group is algorithmically described above by a presentation. The first homology group $H_1(Cw(2z)) = H_1(\mathbf{Cw}(2z))$ can be obtained by Abelianization. All necessary metric data of $Cw(2z)$ can be computed by the matrices of the complete orthoscheme $O(2z)$.

Theorem 6.3. *The cobweb (tube) manifold series $Cw(2z = 8q + 2)$, $1 \leq q \in \mathbf{N}$, for any cobweb polyhedron as a z -cyclic fundamental domain has been algorithmically constructed as above. The construction is illustrated for $Cw(10)$ in Fig. 16. The bases s^{-1} and s of this domain are paired by the screw motion $\mathbf{s} : s^{-1} \rightarrow s$ of rotational angle $2\pi(z-1)/(2z)$. The further face pairing is generated by $z = 4q + 1$ screw motions $a_i : a_i^{-1} \rightarrow a_i$ given by their face pairs (indicated in Fig. 14, where $q = 1$, $z = 5$). The fundamental group has been algorithmically described as above by a presentation.*

There are eight 3-dimensional homogeneous simply connected geometries:

$$\mathbf{E}^3, \mathbf{S}^3, \mathbf{H}^3, \mathbf{S}^2 \times \mathbf{R}, \mathbf{H}^2 \times \mathbf{R}, \sim \mathbf{SL}_2\mathbf{R}, \mathbf{Nil}, \mathbf{Sol} \quad (6.5)$$

(the so-called Thurston geometries), where the above analogous questions can be arisen (see the other works of the present authors cited in references). Our last two illustrations (Fig. 17–18) shows **Sol** and **Nil** geometries, their predicted densest ball packings, found by Jenő Szirmai. **Sol** is a very strange geometry.

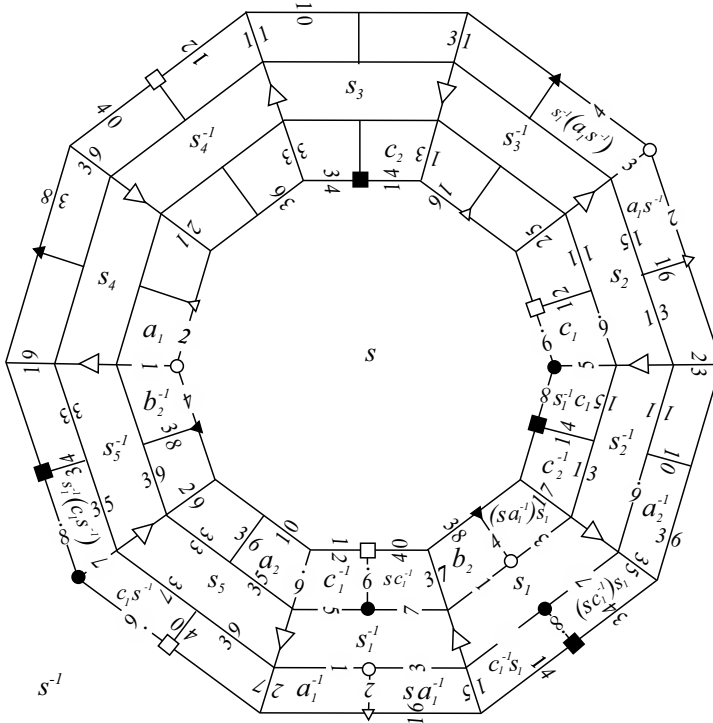

Figure 16. The cobweb (tube) manifold construction $Cw(2z = 10)$ with pentagonal rotational symmetry, or for parameter $z = 4q + 1$, by previous conventions.

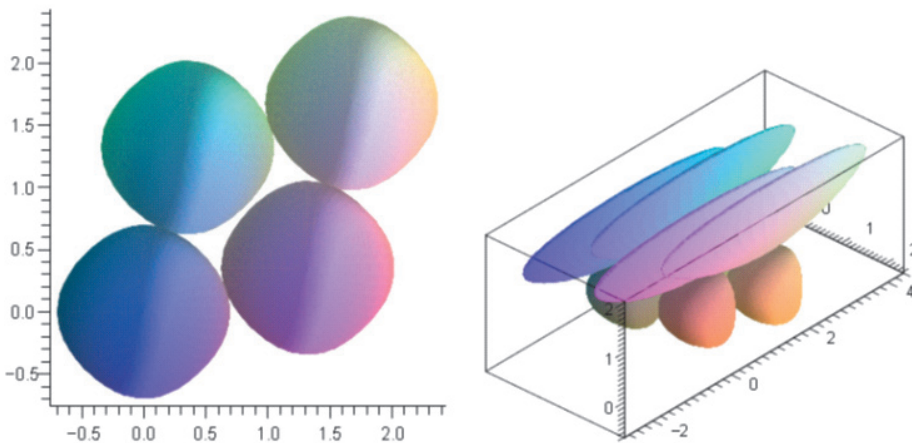

Figure 17. The optimal translation ball arrangement by fundamental lattices in **Sol** space.

Nil has a 2-dimensional Euclidean base plane, it is twisted only in third direction. The unified projective interpretation can help (Molnár, 1997). The central (red) ball is touched by 14 congruent (green) balls by hexagonal rotation symmetry, and this arrangement is extended onto the whole space (by a space group can be denoted by 63_12_1).

Thurston geometries seem to be hopeful in crystallographic applications. “How do know atoms, what is their surrounding space?”

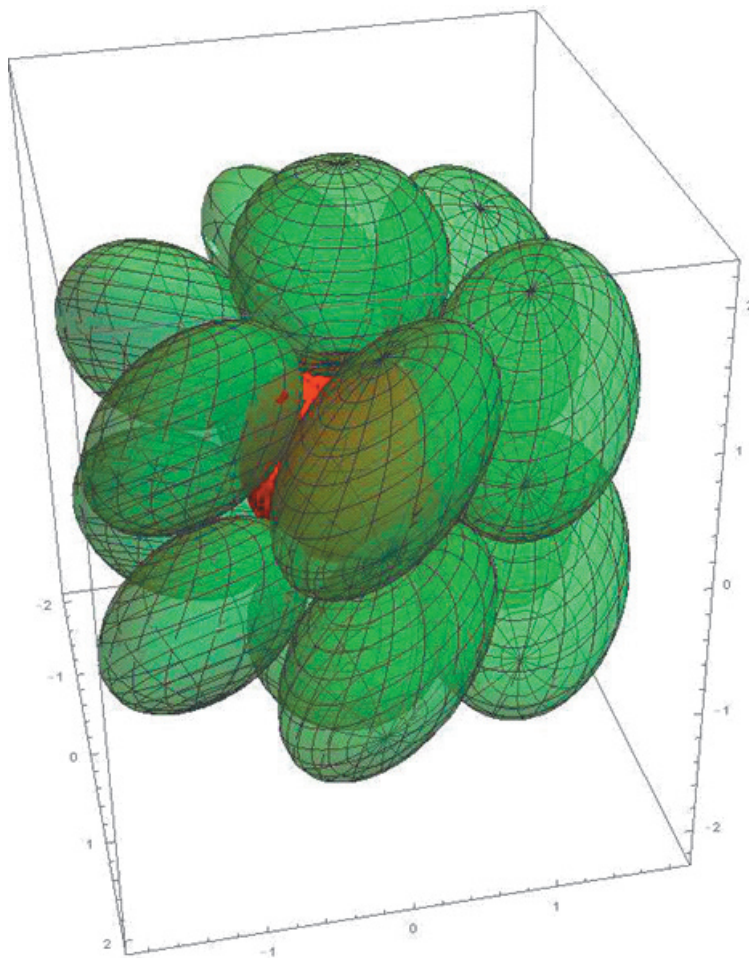

Figure 18. (by B. Schultz): The 14 neighbours ball packing of **Nil** space by (Szirmai, 2007). Its (maximal?) density is 0.780845, larger than the densest Euclidean ball packing by J. Kepler of density 0.7404, proved finally by T. Hales.

References

- [1] BILINSKI, S. (1985). Die quasiregulären Polyeder vom Geschlecht 2. *Österreichische Akademie der Wissenschaften Mathematisch-Naturwissenschaftliche Klasse. Sitzungsberichte. Abteilung II*, 194 (1985), 63–78.
- [2] LUČIĆ, Z., MOLNÁR, E. AND VASILJEVIĆ, N. (2018). An algorithm for classification of fundamental polygons for a plane discontinuous group. In Conder, M. D. E., Deza, A., Ivic Weiss, A. (Eds.), *Discrete Geometry and Symmetry, In Honour of Károly Bezdek's and Egon Schulte's 60th Birthdays* (pp. 257–278), Springer Proceedings in Mathematics & Statistics.
- [3] MOLNÁR, E. (1992). Polyhedron complexes with simply transitive group actions and their realizations. *Acta Mathematica Hungarica*, 59(1–2), 175–216.
- [4] MOLNÁR, E. (1997). The projective interpretation of the eight 3-dimensional homogeneous geometries. *Beiträge zur Algebra und Geometrie*, 38(2), 261–288.
- [5] MOLNÁR, E., PROK, I., SZIRMAI, J. (2006). Classification of tile-transitive simplex tilings and their realizations in homogeneous spaces. In Prékopa, A., Molnár, E. (Eds.), *Non-Euclidean Geometries, János Bolyai Memorial Volume. Mathematics and Its Applications Vol. 581*, (pp. 321–363), Springer.
- [6] MOLNÁR, E., PROK, I., SZIRMAI, J. (2017). On maximal homogeneous 3-geometries and their visualization. *Universe 2017*, 3, 83 MDPI, Basel, Switzerland, <https://doi.org/10.3390/universe4030049>.
- [7] MOLNÁR, E. AND SZIRMAI, J. (2018). Top dense hyperbolic ball packings and coverings for complete Coxeter orthoscheme groups. *Publications de l'Institut Mathématique (Beograd, N. S.)*, 103(117) [2018], 129–146, doi:10.2298/PIM1817129M.
- [8] MOLNÁR, E. AND SZIRMAI, J. (2019). Hyperbolic space forms with crystallographic applications and visualizations. In L. Cocchiarella, L. (Ed.), *ICGG 2018 – Proceedings of the 18th International Conference on Geometry and Graphics. Advances in Intelligent Systems and Computing 809*, pp. 320–337, Springer Nature 2019, https://doi.org/10.1007/978-3-319-95588-9_26.
- [9] PROK, I. (2018). On maximal homogeneous 3-geometries – A polyhedron algorithm for space tilings. *Universe 2018*, 4 (3), 49 MDPI, Basel, Switzerland, <https://doi.org/10.3390/universe4030049>.
- [10] STOJANOVIĆ, M. (2017). Hyperbolic space groups and their supergroups for fundamental simplex tilings. *Acta Mathematica Hungarica*, 153(2), 276–288.
- [11] SZIRMAI, J. (2007). The densest geodesic ball packing by a type of Nil lattices. *Beiträge zur Algebra und Geometrie*, 48, 383–397.

Contact addresses:

Emil Molnár
 Department of Geometry, Institute of Mathematics
 Budapest University of Technology and Economics
 H – 1521, Budapest XI, Egy József str. 1. H. 22, Hungary
 e-mail: emolnar@math.bme.hu

István Prok
 Department of Geometry, Institute of Mathematics
 Budapest University of Technology and Economics
 H – 1521, Budapest XI, Egy József str. 1. H. 22, Hungary
 e-mail: prok@math.bme.hu

Jenő Szirmai
 Department of Geometry, Institute of Mathematics
 Budapest University of Technology and Economics
 H – 1521, Budapest XI, Egy József str. 1. H. 22, Hungary
 e-mail: szirmai@math.bme.hu

Egy szép kövezéstől az elméletig, az alkalmazásokig

MOLNÁR Emil, PROK István és SZIRMAI Jenő

Stanko Bilinski Professor Úr (1909–1998) Emlékére.

Budapesti Műszaki és Gazdaságtudományi Egyetem, Geometria Tanszék
H – 1521, Budapest XI, Egy József út 1, Hungary

Kivonat. Az 1. ábrán (képzeljük el a színeket) az E^2 euklideszi sík ötszög-alaptartományokkal történő szabályos kövezését láthatjuk. Vegyük észre a hatod-rendű α forgatásokat piros-színű középpontokkal, $2\pi/6 = 60^\circ$ szögekkel, és hasonlóan a kék-színű 3-centrumokat (β), zöld-színű 2-centrumokat (γ), a megfelelő 120° , illetve 180° forgásszögekkel. A 6-centrumok mutatják a fellépő eltolások 6-forgású rácsát is. Bármely két ötszöghöz létezik egyetlenegy olyan egybevágósági transzformáció, mely az első ötszöget a másodikba viszi úgy, hogy az egész kövezés önmagára képződik. A transzformációk összessége, melyek mindegyike egy tetszőlegesen rögzített (sárga) (1)-tartományt egy tetszőleges g -tartományba képez, alkotja a $G = \mathbf{p6} = 236$ ($g \in G$) jelű csoportot a kompozíció (egymásutáni végrehajtás) műveletével. Így a fenti G csoportról is geometriai képet alkottunk: Egy út, mely az (1) tartománytól a szomszédokon át a g tartományig vezet, a g csoportelemet az α , β , γ generátorokkal (és azok α^{-1} , β^{-1} , $\gamma^{-1} = \gamma$ inverzeivel) fejezi ki (nem könnyen!). Így képezhetjük a G csoport-gráfot háromféle (színes) irányított éllel, a három generátornak megfelelően.

Képzeljék el, hogy a csoportelmélet egészét ilyen geometriai nyelven is megfogalmazhatjuk, és ez a szemléltetés sok előnnyel jár, vonzó geometriai problémákhoz vezet. Például, a fenti $\mathbf{p6} = 236$ csoportnak 4-féle (topológikus) típusú alaptartománya van (keressük meg a sokszög-típusokat!). A 30-, 60-, 90-fokos iskolai vonalzó sokat segíthet. Képzeljük el az analóg 234, 235 csoportok alaptartományait, ott is 4 típus van, de már az S^2 jelű gömbfelületen; vagy a 237, 238, ... csoportok végtelen sok esetét, ott is 4 típus van, de már a Bolyai-Lobacsevskij-féle H^2 hiperbolikus síkon. A jól ismert (45° , 45° , 90°) iskolai vonalzó segíthet a $G = 244 = \mathbf{p4}$ csoport 3-féle alaptartományának megtalálásában.

Az E^2 euklideszi síkon 17 analóg síkcsoport van (a középkori iszlám művészet zseniális intuitív felfedezése nyomán, pl. a granadai

Alhambra (Vörös vár) kolostor-templom díszítéseiben, Spanyolország). Pólya György, híres magyar matematikus (és matematika-tanár) kedvenc témái is voltak ezek a csoportok. Ezek alaptartományainak mind a 46 topológikus típusát (és a további 47 un. laptranszitiv kövezést) csak 1959-ben publikálta B. N. Delone (Delaunay) orosz matematikus. H. Poincaré már 1882-ben megkísérelte a \mathbf{H}^2 hiperbolikus sík analóg csoportjainak leírását, a \mathbf{C} komplex számsíkon modellezve \mathbf{H}^2 -t, és alkalmas alaptartományok keresésével (később kiderült, hogy kísérlete “eleve reménytelen” volt, de módszerét a térre is kiterjesztette).

Az a *Poincaré-Delaunay probléma*, hogy az \mathbf{S}^2 , \mathbf{E}^2 , \mathbf{H}^2 síkokon egységesen megkeressük az analóg csoportok (kompakt, azaz korlátos és zárt) alaptartományait, hosszú időre nyitott kérdés maradt.

Stanko Bilinski professzor úr, a Zágrábi Egyetem egykori geometria tanára, az akkori jugoszláv és a magyar géométerek tudományos édesapja ugyancsak sokat foglalkozott a hiperbolikus síkcsoportokkal és azok realizációival. Kedvence volt a dupla-tórusz (percc-felület vagy Brezelfläche, szép német nyelvű előadásaiban), lásd [1] csak példaként.

Az “utolsó lépés”, előadásunk fő témája, lehet talán az a számítógépes program, a *program COMCLASS* és az az összefoglaló cikk [2], melyet nem-rég publikáltunk.

Az előadásban röviden, a konferencia-kötetben kicsit hosszabban említjük majd a szerzők térbeli eredményeit. A térbeli megfelelő problémák általában nyitottak, néha “reménytelennek” tűnnek.

Kulcsszavak: szabályos kövezések, síkcsoportok a gömbön, az euklideszi és a hiperbolikus síkon

Pre-service teachers' prior knowledge related to measurement

Zdenka Kolar-Begović^{1,2}, Ružica Kolar-Šuper², Ivana Đurđević Babić²
and Diana Moslavac Bičvić²

¹Department of Mathematics, University of Osijek, Croatia

²Faculty of Education, University of Osijek, Croatia

Abstract. It is of great importance to use mathematical knowledge to solve real problems. Certainly one of the fields of mathematics that plays a major role here is geometry. This paper examines prior knowledge of pre-service teachers in relation to the concept of measurement. Basic knowledge in this field is necessary for a student educated to teach mathematics in the first four grades of primary school as this content is part of the mathematics curriculum for the given period. The participants of the study were first-year pre-service teachers, i.e., a total of 103. The paper focuses on analyzing students' responses to questions referring to measurement. Research results indicate that there are deficiencies in the knowledge of this field, which points to the need for additional increased attention to this concept in the courses offered to students in their studies, thus contributing to increasing the level of knowledge in this field.

Keywords: geometry, measurement, measurement units, pre-service teacher, mathematical concepts

1. Introduction

First-year students have certain knowledge and skills in the field of mathematics acquired during their previous education. In this paper, we study prior knowledge of first-year pre-service teachers in relation to measurement. This research was inspired by the analysis of student work, midterm and final exams, as well as their responses in oral exams. Namely, it has been noted that, while solving tasks, students often make mistakes, which are caused by the fact that they are not familiar with some basic concepts that are assumed to have been adopted during their primary and secondary education, and these are the assumptions mathematics courses offered to pre-service teachers are based on. When solving tasks referring to the

perimeter and area of geometric plane shapes and the volume of solid figures, it has been noted that some students make mistakes when it comes to understanding and applying formulas to determine perimeter, area, and volume. It has also been noted that some students either do not know or do not understand units of length, area and volume. In order to establish the level of prior knowledge related to the concept of measurement, students were given tasks examining their knowledge of measurement. The study was conducted with the first-year pre-service teachers before any geometric topic was dealt with.

Knowledge of pre-service teachers related to geometric topics is very important for their study since as teachers they will be the first ones to provide their students with knowledge from that field.

According to the Croatian National Curriculum Framework (MZOŠ, 2011), mathematical concepts are divided into the following domains: *Numbers, Algebra and Functions, Form and Space, Measuring, and Data*. In relation to the *Measuring* domain, the Curriculum Framework outlines that at the end of the first cycle of education, comprising first four grades of primary school, students will be able to:

- “compare and assess length, volume, mass, time, and temperature, and measure them by using appropriate measuring devices,
- know the names for standardized units of measurement for length, area, volume (liters), mass, time, and temperature, and use them in their everyday lives,
- perform money calculations (in kuna and lipa) in everyday situations,
- calculate the perimeter of simple shapes, especially triangles, rectangles, and squares, and the area of rectangles and squares,
- approximate or accurately measure the area of simple shapes by counting unit squares, and
- determine measurable features of simple objects or phenomena in everyday situations, and apply measurement skills to solve everyday problems.” (MZOŠ, 2011, p. 118)

Led, *inter alia*, by the expected achievements of students at the end of the first cycle of education, we created the tasks aimed at assessing student knowledge in this particular domain.

One of the goals of this research is to identify possible difficulties that exist in relation to prior knowledge of pre-service teachers in the field of measurement.

2. Theoretical background

Geometry emerged around the 20th century BC from practical needs of the ancient Babylonians and Egyptians who had to carry out land surveys after the flooding of the Nile. When translated from Greek, the name *geometry* means Earth measurement. Greeks made geometry a right, pure, theoretical, abstract, and exact science. In the 3rd century BC, Euclid gathered up and systematized all of the knowledge of elementary geometry in his work, a book called *The Elements*.

To this day, many mathematical texts reflect this formal approach to geometry, ignoring a strong link between geometry and real life. One of the tasks of teaching geometry is to help develop spatial knowledge (Clements & Battista, 1986).

There are many examples showing that the introduction of measurement activities contributes to better understanding and linking of geometry and real life. "Even when geometry is taught, it often becomes a vehicle for the study of proofs and structure-building rather than a tool for earth measurement. It has replaced the study of patterns as curiosities with the proving of theorems. The fun is gone - it is spectator sport rather than a game in which to participate as a player." (Trimble, 1979, p. 220)

Numbers and geometry are the starting points for the initial teaching of mathematics. It is common, though perhaps somewhat simplified, to consider measurement as the application of numbers in geometry. Measurement is an important human activity. It represents an everyday skill. It is the basic tool of science which represents a link between the real world and mathematics (Cooper, 1993).

Bishop (1988) treats measuring as one of the six groups of fundamental activities which, according to his analyses, are said to be universal because they can be encountered in all cultural groups studied and are necessary and sufficient for the development of mathematical knowledge. Other fundamental activities include counting, locating, designing, playing and explaining. According to Bishop the measurement includes the following activities and notions: comparing, ordering, length, area, volume, time, temperature, weight, development of units – conventional, standard, metric system, measuring instruments, estimation, approximation, error.

Measuring skills enable children to have a strong link between the abstract world of numbers and the concrete world of physical objects. Before children learn how to measure, they can only describe objects or quantities with relatively vague expressions such as "big" or "many". As they learn how to measure, children acquire skills to describe the quantities more precisely. Now they can talk about the magnitude of a quantity as the number of units. The measuring unit is used as a bridge between the object and the number used to describe its size. The concept of a unit is the central idea on which every measurement is based. In fact, the ability of children to measure depends to a large extent on their understanding of the unit in measurement situations (Hiebert, 1981).

Tucker (2009) points out that units of measurement are extremely important in understanding the equations and terminology and "units are words, which reach students in ways that algebra, graphs, and numbers cannot".

Students experience great difficulties with measuring. A large body of research deals with these difficulties. Battista (2006) points out that the concept of length is very important both in everyday life and in geometry. He proposes using tasks that could help us understand students' conceptual knowledge of the notion in question, and discusses strategies students use to compare the lengths of the given line segments. He believes that many difficulties in problem solving may also arise

from insufficient understanding and the difference in the usage of the word *length* in real-world and mathematical contexts.

Much research provides guidelines for teachers on how to help students overcome difficulties in this field. By using age-appropriate literature, it is possible to increase students' interest in these topics and help them adopt certain concepts (Bintz, Moore, Wright & Dempsey, 2011). Some authors point out that the use of the Logo program contributes to a better understanding of measurement concepts (Clements & Sarama 1995; Clements, 1997).

Numerous studies have shown a very low level of knowledge of pre-service teachers related to geometric topics. Thus, for example, in the research carried out by Baturu and Nason (1996), it was found that knowledge of first-year pre-service teachers concerning area measurement is very poor. Much of their basic knowledge was erroneous or incomplete, and often unconnected. The ability of students to move from one form of presentation to another was very limited.

Relying on research in the literature, Steele (2013) outlines the following three reasons for poor achievements in geometry and measurement: a weak approach to basic education, challenges in relation to the introduction of geometry and measurement to classes, and limited knowledge of teachers in this field.

In their research, Cunningham and Roberts (2010), Marchis (2012) emphasize that special attention should be paid to teaching geometric concepts to future teachers.

3. Methodology and results

This research was conducted with first-year students studying at the Faculty of Education in Osijek and its subsidiary study in Slavonski Brod. Study participants included 103 first-year pre-service teachers studying at the Faculty of Education in Osijek (53.4 %) and its subsidiary study in Slavonski Brod (46.6 %).

The goal of this research was to establish the level of first-year pre-service teachers' prior knowledge of primary and secondary school geometric concepts in the field of measurement. We also wanted to examine the relationship between pre-service teachers' prior knowledge of measurement and the following elements: a type of secondary school education completed, the selected study module at the faculty, the favorite field of mathematics, the grades in mathematics subjects achieved in primary and secondary schools, the level of mathematics they opted to take in the state graduation exam and the grade they got in the given exam, and the grade in physics subjects they got in secondary school.

Students were asked to fill out a questionnaire consisting of two parts, i.e., a section containing demographic information, and a section that was used to identify pre-teachers' prior knowledge of geometry related to measurement, which they acquired in their primary and secondary school education. The tasks were created according to the difficulties identified by analyzing solutions to tasks offered by

students in the previous three generations (i.e., in the last three academic years) in midterm and final exams in mathematics courses.

Demographic information related to the type of secondary school education completed, the selected study module (i.e., developmental studies, computer science, and foreign languages), the attitude toward mathematics as a subject (1 — definitely not my favorite subject, 2 — not my favorite subject, 3 — neither my favorite nor my least favorite subject, 4 — my favorite subject, 5 — definitely my favorite subject), the favorite field of mathematics (numbers; algebra and functions; geometry; data, probability and statistics; none), the grades in mathematics subjects achieved in primary and secondary school, the level of mathematics they opted to take in the state graduation exam and the grade they got in the given exam, the grade in physics subjects they got in secondary school, and experience of using dynamic geometry software.

The second section consisted of nine questions. The first three questions concerned students' knowledge of units of measurement (i.e., fundamental and derived units, and the connection between them). Question 4 referred to recognition of geometric shapes and calculations of the perimeter and area of each of these shapes (a triangle, a rectangle, a square and a parallelogram). In Question 5, students were supposed to recognize two solid figures (a cuboid and a right quadrilateral pyramid), design their nets and calculate the volume and surface area of these solids. In Question 6, students were asked to indicate which activities (or formulas) related to geometry they remember from their previous education. Question 7 examined student assessment of length. In Question 8, students had to choose the shortest path between two points (of the six solution offered, Figure 1) and explain their answer.

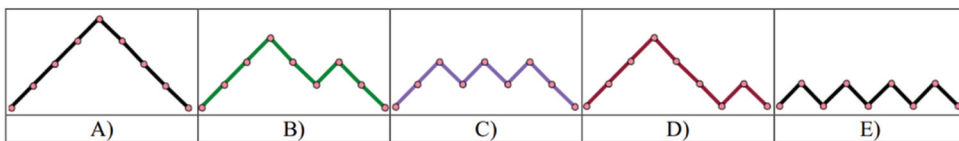

F) All paths are of equal length.

Figure 1. Task 8.

Question 9 read:

Dora had several pieces of cardboard in the form of a square of 16 cm^2 . She cut them into squares and right triangles. She arranged a few of the pieces to the rabbit, as given in the figure below. Find the area and perimeter of the figure of rabbit (Figure 2).

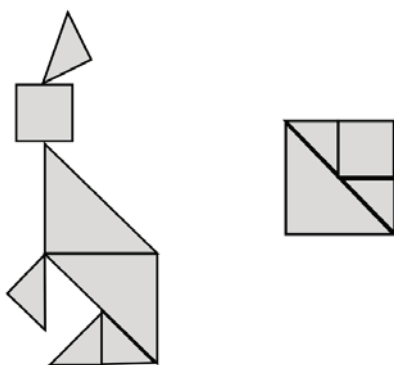

Figure 2. Task 9.

For the purpose of this paper, the first five tasks, as well as tasks 8 and 9, were taken into account for assessing the level of pre-service teachers' prior knowledge. Respondents could have scored a total of 50 points (with a total of 23 points allocated to knowing units of measurement and comparing the length of paths and a total of 27 points for recognizing 2D shapes and 3D figures and calculating the perimeter and area of the given 2D shapes and calculating the volume and surface area of the given 3D figures). Respondents were divided into two categories according to the number of points they achieved. The levels of prior knowledge of respondents who achieved less than 30 points and of those who achieved 30 or more were characterized as low and satisfactory, respectively.

Most respondents (93.2 %) were female students and more than half of respondents (57.28 %) were enrolled into the developmental studies module. Given the type of secondary school completed by respondents, the majority of respondents (see Table 1) come from high schools and grammar schools (61.17 %) and the lowest number of respondents comes from technical vocational schools (4.85 %).

Table 1. Type of secondary school attended by respondents.

Schools by type	Frequency	Relative frequency (%)
High schools and grammar schools	63	61.17
Secondary vocational schools of economics	19	18.45
Technical vocational schools	5	4.85
Other	16	15.53

According to their responses, 45.63 % of respondents had an A (i.e., an excellent grade) in mathematics in their primary school education (Figure 3), while only 9.71 % had an A (i.e., an excellent grade) in mathematics in their secondary school education (Figure 4).

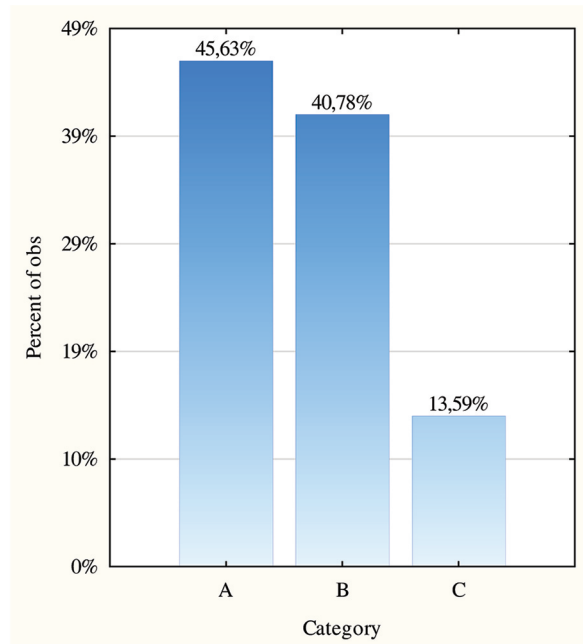

Figure 3. Categories including the average grade in primary school mathematics subjects.

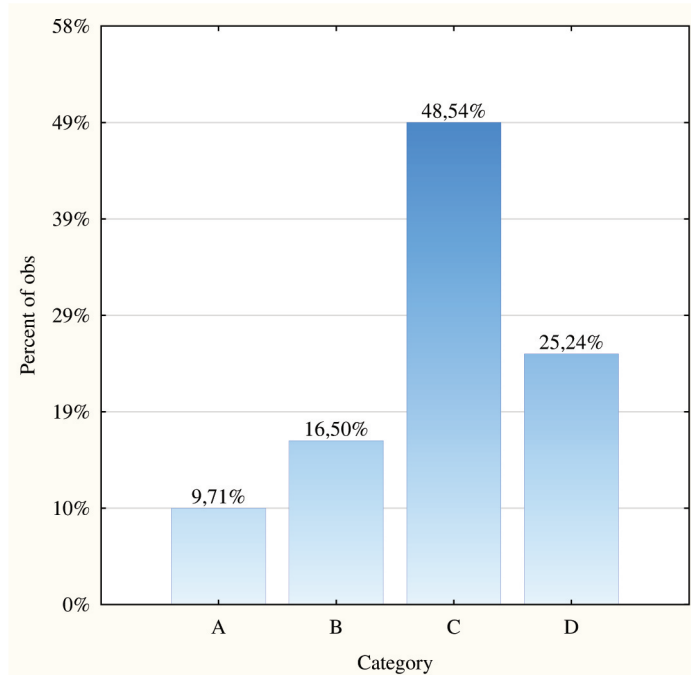

Figure 4. Categories including the average grade in secondary school mathematics subjects.

More than a quarter of respondents (27.18 %) did not have any physics classes in their secondary school education, and only 6.8 % of respondents had an A (i.e., an excellent grade) in physics in their secondary school education.

As many as 89.32 % of respondents opted for the basic level of mathematics (B level) in the state graduation exam, while less than one ninth of respondents (10.68 %) decided to take a higher level mathematics (A level) exam.

Almost a third (33.01 %) and 43.69 % of respondents had a D (i.e., sufficient) and a C (i.e., good) in the Mathematics state graduation exam, respectively. Only 4.85 % of respondents had an A (i.e., excellent), and less than one fifth of respondents (18.45 %) had a B (very good) in the Mathematics state graduation exam.

Only 2.91 % of respondents have a very positive attitude toward mathematics and consider it a favorite subject, while 18.45 % consider it the least favorite subject, and 45.63 % of respondents do not have any particular attitude toward this subject (neither their favorite nor their least favorite subject).

Students were asked to indicate their favorite fields of mathematics. In so doing, they were able to choose more than one field. 32.04 %, 14.56 %, 7.77 % and 5.83 % of respondents selected Numbers, Algebra and Functions, Geometry, and Data (Probability and Statistics), as one of their favorite fields, respectively, whereas 41.75 % of respondents stated that they did not have any favorite field of mathematics (see Table 2).

Table 2. Favorite fields of mathematics selected by students.

Favorite field	Frequency	Relative frequency (%)
Numbers	33	32.04
Algebra and Functions	15	14.56
Geometry	8	7.77
Data (Probability and Statistics)	6	5.83
None	43	41.75

The vast majority of respondents (88.35 %) argued that they did not have any experience of using dynamic geometry software in mathematics classes. Of 12 respondents (i.e., 11.65 % of all respondents) who argued that they had used dynamic geometry software in their mathematics classes, 6 of them (5.83 %) indicated that they had used GeoGebra software, while others did not name any particular software.

When analyzing answers to questions referring to an assessment of respondents' prior knowledge, it can be seen that the same percentage of respondents (i.e., 87.38 %) stated the correct fundamental units of measurement for length and mass, 75.73 % of respondents stated the correct fundamental unit of measurement for time, while only 14.71 % of respondents stated the correct fundamental unit of measurement for temperature.

84.47 % of respondents specified the correct units for measuring length, while 42.72 % of respondents were able to explain the relationship between them. The results obtained in relation to the units of measurement for area are somewhat weaker than the aforementioned ones. 63.11 % of respondents stated the correct units of measurement for area, and 12.62 % explained the relationship between them. With respect to units of measurement used for measuring volume, 45.54 % of respondents stated the correct units of measurement, while 7.77 % of respondents could clarify the relationship between them. 80.58 % of respondents stated the correct units of measurement for mass, and 16.50 % of respondents clarified the relationship between them. 66.99 % of respondents stated the correct units of measurement for time, and 30.10 % clarified the relationship between them.

As far as presentations of units of measurement in terms of freehand drawings are concerned, presentations of 1 cm, 1 dm, 1 cm² and 1 cm³ are found acceptable by 82.52 %, 61.17 %, 35.92 %, and 29.13 % of respondents, respectively.

Figure 5 shows an acceptable solution of one of the respondents. Two unacceptable solutions are given in Figures 6 and 7. Almost a third of respondents (32.04 %) made a mistake of the same type as the answer given in Figure 7.

1 cm	
1 dm	
1 cm ²	
1 cm ³	

Figure 5. Presentation of units of measurement for length, area and volume (student work).



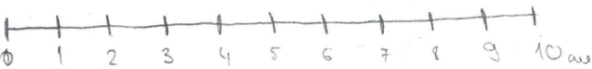
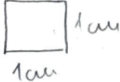
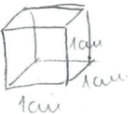

1 cm	
1 dm	
1 cm ²	
1 cm ³	

Figure 6. Presentation of units of measurement for length, area and volume (student work).





1 cm	
1 dm	
1 cm ²	
1 cm ³	

Figure 7. Presentation of units of measurement for length, area and volume (student work).

In the next task, respondents were asked to name certain geometric plane shapes and give formulas for calculating their perimeter and area. All students

recognized the triangle, whereby 67.96 % and 13.86 % of respondents stated the correct formulas for finding the perimeter and the area of a triangle, respectively. It should be noted that more than half of respondents (55.34 %) indicated that the area of a triangle is equal to the product of the lengths of its sides. The vast majority of respondents (91.26 %) identified the rectangle; 68.93 % and 61.17 % of respondents stated the correct formulas for finding its perimeter and its area, respectively. 70.87 % of respondents identified the square; 66.99 % and 53.37 % of respondents stated the correct formulas for finding its perimeter and its area, respectively. 66.99 % of respondents identified the parallelogram; 35.92 % of respondents stated the correct formula for finding its perimeter and only one respondent (0.97 %) stated the correct formula for finding the area of a parallelogram. It should be noted that almost a quarter of respondents (24.27 %) indicated that the area of a parallelogram is equal to the product of the adjacent lengths of its sides.

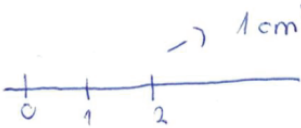
When it comes to naming the given solid figures (a cuboid and a pyramid), drawing their net patterns and specifying formula for finding their volume and surface area, it was found that 73.79 % and 94.17 % of respondents identified the cuboid and the pyramid, respectively. Other results are presented in Table 3.

Table 3. Results obtained for Task 5.

Task	Correct answers (%)
Name of the 3D shape – cuboid	73.79
Net of a cuboid	39.81
Volume of a cuboid	19.42
Surface area of a cuboid	0.97
Name of the 3D shape – pyramid	94.17
Net of a pyramid	41.75
Volume of a pyramid	0.97
Surface area of a pyramid	4.85

In Task 8, 87.38 % of respondents answered the question correctly.

In Task 9, respondents were supposed to find the area and perimeter of the given geometric plane shape that consisted of multiple right-angled triangles and squares obtained by cutting out a square of 16 cm^2 . 85.44 % of respondents did not find the area of this shape, and nobody was successful in finding the perimeter. Figures 8 and 9 illustrate acceptable student solutions to Task 9 for the area of the given shape.

79.61 % of pre-service teachers showed a low level of prior knowledge (42.72 % of respondents scored 20 and less points, while 36.89 % reached 21 to 29 points), and only 20.39 % of pre-service teachers demonstrated a satisfactory level of prior knowledge (i.e., they achieved 30 and more points).

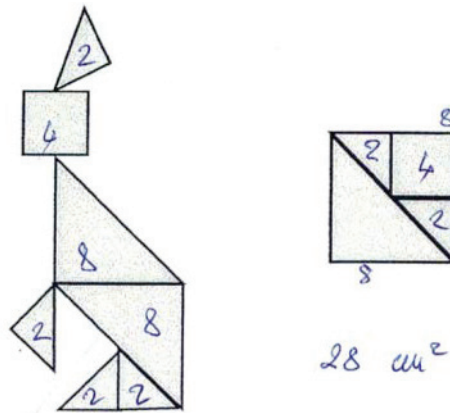

Figure 8. Student solution to Task 9.

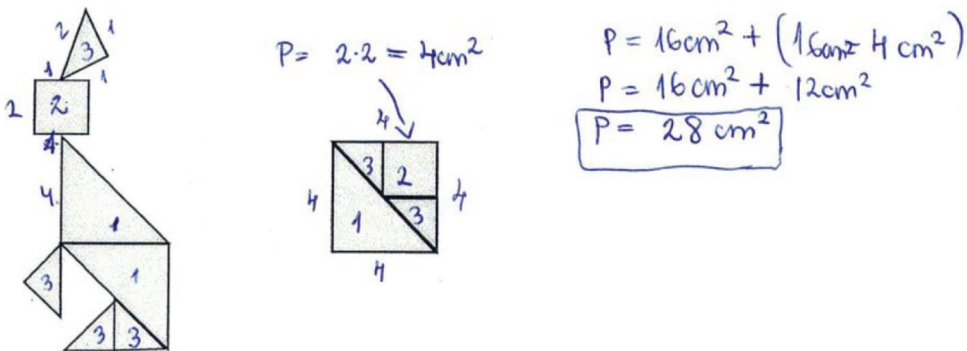

Figure 9. Student solution to Task 9.

The χ^2 test (a chi-square test of association) was performed to see whether at the 0.05 significance level there exists an association between the categories of pre-service teachers' prior knowledge and the type of secondary school they attended, the attitude toward mathematics as a subject, the grades in mathematics subjects they got in primary and secondary school and the grade in physics they got in secondary school, the level of mathematics they opted to take in the state graduation exam and the grade they got in the given exam, and the study module they enrolled in.

Test results have shown that there is a statistically significant relationship between the level of pre-service teachers' prior knowledge and the study module they enrolled in ($\chi^2(2) = 12.15$, $p = 0.002$), between the level of pre-service teachers' prior knowledge and the grade referring to the primary school mathematics GPA ($\chi^2(2) = 13.85$, $p = 0.001$), and between the level of pre-service teachers' prior knowledge and the grade they got in the mathematics exam as part of the state graduation exam ($\chi^2(3) = 12.41$, $p = 0.006$).

Since the relative frequencies of the level of pre-service teachers' prior knowledge are not the same in all categories of variables observed, these results suggest that the level of prior knowledge in this sample refers to the selected study module of students (52.43 % of respondents with low levels of prior knowledge have chosen the developmental studies module, while 14.56 % of respondents with low levels of prior knowledge have chosen the foreign language module, and 12.62 % of respondents with low levels of prior knowledge have chosen the computer science module).

The test has also shown that there is no statistically significant association between the level of pre-service teachers' prior knowledge and the type of secondary school they attended ($\chi^2(3) = 4.80$, $p = 0.19$), between the level of pre-service teachers' prior knowledge and the grade referring to the secondary school mathematics GPA ($\chi^2(3) = 4.50$, $p = 0.21$) and the grade referring to the secondary school physics GPA ($\chi^2(4) = 8.09$, $p = 0.09$), between the level of pre-service teachers' prior knowledge and the level of mathematics they opted to take in the state graduation exam ($\chi^2(1) = 1.94$, $p = 0.16$), and between the level of pre-service teachers' prior knowledge and their attitude toward mathematics as a subject ($\chi^2(4) = 6.91$, $p = 0.14$).

For associations between the level of pre-service teachers' prior knowledge and variables for which a chi-square test of association established a statistically significant association at the 0.05 significance level, the strength of this relationship was measured by means of Cramer's V. The test showed that there is a strong relationship between the level of pre-service teachers' prior knowledge and the study module they enrolled in ($V = 0.34$), and a very strong relationship between the level of pre-service teachers' prior knowledge and the grade referring to the primary school mathematics GPA ($V = 0.37$) and the grade they got in the mathematics exam as part of the state graduation exam ($V = 0.35$).

4. Discussion and conclusion

Based upon data obtained from this research, it can be noticed that first-year pre-service teachers lack knowledge and understanding of units of measurement and conversion from one unit to another, especially for the area and volume. A certain number of students are unable to find the perimeter and area of geometric plane shapes (a rectangle, a square, a parallelogram, and a triangle). Some mistakes of the same type were recorded with a large number of students, such as finding the area of a triangle as the product of the lengths of its sides and the area of a parallelogram as the product of the lengths of adjacent sides.

In their research with the first-year teacher education students, Baturo and Nason (1996, p. 262) stated that: "the relationship between the area of a triangle and the area of the rectangle which encloses it is not known. Thus, the formula for calculating the area of a triangle had no meaning for these students and they were unable to explain why it is necessary to divide by 2".

A large number of students demonstrated that they do not understand units of measurement for area and volume, displaying these units of measurement for area and volume linearly, such that 1 cm^2 was displayed as a line segment of length 2 cm, and analogously, 1 cm^3 was displayed as a line segment of length 3 cm. When defining the area of the figure given in Task 9, an error was made and a unit of linear measure is used instead of a unit of area measure (when determining the area of a square, it says $4 \text{ cm} \times 4 \text{ cm} = 16 \text{ cm}$ instead of 16 cm^2). A certain number of students failed to interpret or understand a cuboid correctly and mixed it with its two-dimensional analog, a rectangle.

The results of some other research in the field of measurement also corroborate the results of this study. Thus, for example, in a study conducted with 92 undergraduate students who are second-year pre-service elementary teachers and first- and second-year elementary science teachers it was found that pre-service elementary teachers and elementary science teachers who participated in the research fail to understand the basic scientific concepts correctly (Keles, Ertas, Uzun & Cansiz, 2010). They found that students have difficulty in understanding units of measurement, naming devices used for measuring certain quantities, and converting units of measurement from one to another.

Such results, which show that there are major deficiencies and misconceptions about knowledge of the content in the field of measurement, require special attention and point to the need for more detailed and comprehensive processing of these concepts in mandatory mathematics courses or introducing an elective course covering this field. There are also some other ways that may contribute to a better understanding of this field of geometry (e.g., introducing a pre-session course or intensifying work with students in this area).

References

- [1] BATTISTA, MICHAEL T. (2006). Understanding the Development of Students' Thinking about Length. *Teaching Children Mathematics*, 13(3), 140–146.
- [2] BATURO, A., & NASON, R. (1996). Student Teachers' Subject Matter Knowledge within the Domain of Area Measurement. *Educational Studies in Mathematics*, 31(3), 235–268.
- [3] BINTZ, WILLIAM P., MOORE, SARA D., WRIGHT, P., & DEMPSEY, L. (2011). Using literature to teach measurement. *The Reading Teacher*, 65(1), 58–70.
- [4] BISHOP, ALAN J. (1988). Mathematics Education in its Cultural Context. *Educational Studies in Mathematics*, 19(1), 179–91.
- [5] CLEMENTS, D. H. (1997). Students' Development of Length Concepts in a Logo-Based Unit on Geometric Paths. *Journal for Research in Mathematics Education*, 28(1), 70–95.
- [6] CLEMENTS, D. H., & SARAMA, J. (1995). Design of a Logo Environment for Elementary Geometry. *The Journal of Mathematical Behavior*, 14(4), 381–398.
- [7] CLEMENTS, D. H., & BATTISTA, MICHAEL T. (1986). Geometry and Geometric Measurement. *The Arithmetic Teacher*, 33(6), 29–32.

- [8] COOPER, T. (1993). *Teaching measurement processes in the primary school*. The Centre for Mathematics and Science Queensland University of Technology, Queensland.
- [9] CUNNINGHAM, R. F., & ROBERTS, A. (2010). Reducing the mismatch of geometry concept definitions and concept images held by pre-service teachers. *Issues in the Undergraduate Mathematics Preparation of School Teachers, 1* (Content Knowledge), 1–17.
- [10] HIEBERT, J. (1981). Units of Measure: Results and Implications from National Assessment. *The Arithmetic Teacher, 28*(6), 38–43.
- [11] KELES, Ö., ERTAS, H., UZUN, N., & CANSIZ, M. (2010). The understanding levels of preservice teachers' of basic science concepts' measurement units and devices, their misconceptions and its causes. *Procedia-Social and Behavioral Sciences, 9*, 390–394.
- [12] MARCHIS, J. (2012). Preservice primary school teachers' elementary geometry knowledge. *Acta Didactica Napocensia, 5*(2), 33–40.
- [13] STEELE, M. D. (2013). Exploring the mathematical knowledge for teaching geometry and measurement through the design and use of rich assessment tasks. *Journal of Mathematics Teacher Education, 16*(4), 245–268.
- [14] TRIMBLE, H. (1979). Measure for measure. *The Mathematics Teacher, 72*(3), 217–220, Published by: National Council of Teachers of Mathematics.
- [15] TUCKER, T. (2009). On Measurement. *Math Horizons, 16*(3), p. 34.
- [16] *National Curriculum Framework for Preschool Education and General Compulsory and Secondary Education*. Retrieved October, 2018 from http://mzos.hr/datoteke/Nacionalni_okvirni_kurikulum.pdf

Contact addresses:

Zdenka Kolar-Begović
Department of Mathematics, University of Osijek
Trg Ljudevita Gaja 6, 31000, Osijek, Croatia
Faculty of Education, University of Osijek
Cara Hadrijana 10, 31000, Osijek, Croatia
e-mail: zkolar@foozos.hr

Ružica Kolar-Šuper
Faculty of Education, University of Osijek
Cara Hadrijana 10, 31000, Osijek, Croatia
e-mail: rkolar@foozos.hr

Ivana Đurđević Babić
Faculty of Education, University of Osijek
Cara Hadrijana 10, 31000, Osijek, Croatia
e-mail: idjurdjevic@foozos.hr

Diana Moslavac Bičević
Faculty of Education, University of Osijek
Cara Hadrijana 10, 31000, Osijek, Croatia
e-mail: dmoslavac@foozos.hr

Predznanje studenata učiteljskog studija vezano uz koncept mjerenja

Zdenka Kolar-Begović^{1,2}, Ružica Kolar-Šuper², Ivana Đurđević Babić² i
Diana Moslavac Bičvić²

¹Odjel za matematiku, Sveučilište u Osijeku, Hrvatska

²Fakultet za odgojne i obrazovne znanosti, Sveučilište u Osijeku, Hrvatska

Sažetak. Velika je važnost korištenja matematičkog znanja u rješavanju realnih problema. Svakako jedno od područja matematike koje u tome igra veliku ulogu je područje geometrije. U ovom članku istražuje se predznanje studenata učiteljskog studija vezano uz koncept mjerenja. Osnovna znanja iz ovog područja nužna su za kadar koji se obrazuje za poučavanje matematike u prva četiri razreda osnovne škole s obzirom na zastupljenost ovih sadržaja u programu matematike za navedeno razdoblje. Sudionici istraživanja su studenti prve godine učiteljskog studija, njih 103. Rad je usmjeren na analizu odgovora studenata na pitanja iz domene mjerenja. Rezultati istraživanja upućuju na to da postoje manjkavosti u predznanju iz ovog područja, što upućuje na potrebu dodatnog posvećivanja pažnje ovom konceptu na kolegijima koji se studentima nude na studiju, čime bi se doprinijelo povećanju razine znanja iz ovog područja.

Gljučne riječi: geometrija, mjerenje, mjerne jedinice, studenti učiteljskog studija, matematičke domene

Teachers' opinions on geometric contents in the curriculum for the lower grades of primary school

Sanela Nesimović¹ and Karmelita Pjanić²

¹Faculty of Educational Sciences, University of Sarajevo, Sarajevo, Bosnia and Herzegovina

²Faculty of Pedagogy, University of Bihać, Bihać, Bosnia and Herzegovina

Abstract. In order to obtain a higher quality of education, each one of its segments should be maximally arranged. Teachers are an essential part of quality education in mathematics. Their role is irreplaceable: the way they teach and think about their profession directly influences the results of their work, i.e. the learning outcomes of their pupils. The manner and the quality of their work depend on their opinion (or attitude) towards other segments of the educational system in mathematics.

The aim of this paper is to investigate teachers' opinions on geometric contents in the curriculum for the first five grades of primary school and the quality of mathematics textbooks for the first five grades, along with their reflections on the teaching methods used in teaching the geometric contents. For this purpose, the survey was conducted among 108 teachers from 11 primary schools in Sarajevo Canton.

By analyzing the results of the survey, we can notice that the teachers of different educational levels and years of work experience had the same or similar opinions to all the questions dealing with the representation of geometric contents, the quality of textbooks for a particular grade as well as the selection and application of teaching methods in teaching geometry.

Keywords: geometry, primary education, teachers' opinions, textbook, teaching methods

1. Introduction

The teacher's profession is one of the oldest professions. Although the teacher still represents one of the main links in the chain of educational process, his/her role is much more complex than it was before. Today, the teacher is at the same time

the planner, programmer, organizer, diagnostician, researcher, guide, innovator, adviser and educator. The way teachers work today must be more inventive and democratic. The competences of those who teach, such as teaching skills, material organization and presentation, the learning atmosphere created between teachers and pupils and teachers' attitudes towards mathematics are very important factors in the development of mathematical knowledge among pupils. The development of technology has contributed to the questioning of the importance of teachers and their work. At the same time, parents' expectations from the educational system increased. Demand for instant knowledge and easy access to all kind of information reduce the role and authority of teachers. All mentioned factors make relationship among teachers, pupils and parents more complex.

2. Theoretical background

Modern educators must constantly be part of the process in which they learn actively, and follow, upgrade and develop their mathematical and methodical competences. Hill, Rowan and Ball (2005) have shown that the quality of math teaching depends on how much of mathematical content knowledge the teacher has. However, knowing mathematics is not the same as knowing how to teach others. Therefore Ball et al. (Ball, Hill, Bass, 2005, Hill, Rowan, Ball, 2005; Hill, Ball, 2004) also emphasize the importance of pedagogical content knowledge. Teachers must be consistent, professional, creative, exemplary in every respect, positive, and emotionally stable. Bush (1986) has come to the conclusion in his research that many teachers' decisions related to the ways of teaching certain contents are based on the ways in which they were taught before and that textbooks often impose the ways in which certain contents are to be taught. He pointed to the limitations that were caused by the use of textbooks. Those limitations are reflected in following: as textbooks serve as the models of instruction then pedagogical approaches reflected in the textbook in all probability will be translated into the classroom practice.

Teaching mathematics is a complex and demanding job. The teacher's expertise is needed, but it is not a sufficient precondition for success. Content knowledge – mathematical content knowledge and pedagogical content knowledge are of vital importance to math teachers. Mathematical content knowledge helps to understand how to use, interpret and learn a certain algorithm instead of just knowing how to use it to get a specific answer (Lenhart, 2010). It allows teachers to assess the appropriateness of the mathematical content represented in the curriculum and textbooks. Pedagogical knowledge helps teachers to choose effective strategies, methods and ways of working with pupils.

3. Methodology

The teacher's role in teaching geometric contents in the initial teaching of mathematics is irreplaceable. Therefore, it is important to consider the teacher's views on the geometric contents that are taught in the initial teaching of mathematics and the quality of textbooks used in teaching practice, and to examine whether the choice of geometric teaching methods in the initial teaching of mathematics and the choice

of forms of class organization of pupil work depends on the level of education and the time teachers previously spent in teaching.

For the purpose of the research we have set the following research tasks:

1. Examine the views of the teachers of the Canton of Sarajevo on the representation and appropriateness of geometric contents in the initial teaching of mathematics.
2. Examine the views of the teachers of the Canton of Sarajevo on the quality of math textbooks from the first to the fifth grade.
3. Examine whether the teacher's opinion on the methods and forms of class organization of pupil work in teaching geometric contents is conditioned by their professional qualification and years of work experience.

We examined the opinions of the teachers of primary schools from the Canton of Sarajevo area, namely 108 of them from 11 Sarajevo Canton primary schools. The questionnaire for teachers consisted of 4 general-type questions and 9 questions related to the teaching of mathematics. General type questions referred to the level of professional qualification, years of work experience, the grade that the surveyed teacher currently teach and the name of the school in which he/she works. Other questions related to the forms and methods of work most commonly used in math classes where geometric contents are taught, as well as to teachers' opinions on math textbooks and curricula. We also asked for the teacher's opinion of what is most difficult to teach and what is most difficult for pupils to learn, as well as their opinions about the number of teaching hours scheduled for geometry. In the end, the teacher was asked to use grades from 1 to 5 to evaluate textbooks and curricula of mathematics (especially geometry) from the first to the fifth grade.

4. Results and discussion

The structure of the respondents by years of work experience, qualifications and the grade that a teacher was teaching during the research period is given in the following table.

Table 1. Structure of respondents.

<i>n</i>		Count	Column N %
	respondents	108	100.0 %
Level of professional qualification	College	20	18.5 %
	Faculty	72	66.7 %
	Master level and more	16	14.8 %
Years of work experience	up to 10 years	30	27.8 %
	from 11 to 20 years	53	49.1 %
	over 20 years	25	23.1 %
The grade you currently teach	First	28	25.9 %
	Second	22	20.4 %
	Third	22	20.4 %
	Fourth	26	24.1 %
	Fifth	10	9.3 %

4.1. The first research task

For the purpose of determining the teachers' opinion on the representation and appropriateness of geometric contents in the initial teaching of mathematics, several questions have been asked to teachers.

In order to better understand the teacher's response, we will provide information on geometric contents in the curriculum. Mathematics curriculum envisage 68 teaching hours in the first grade (2 teaching hours per week). Of these, 16 teaching hours (or 25.53 %) are provided for geometric contents. Pupils in the first grade should recognise shapes of objects (sphere, cube, cilinder and pyramid), plane and curved surfaces, plane figures (triangle, circle, rectangle and square) and lines. There are 105 teaching hours of mathematics (3 hours per week) in both the second and in the third grade, among them 20 hours (or 19.05 %) for teaching geometry in the second grade and 14 hours (or 13.33 %) for teaching geometry in the third grade. The second grade pupils should recognise connections among solids, plane figures, lines. They learn about straight line segment. The third grade pupils learn about plane figures. In both the fourth and the fifth grade there are 140 teaching hours of mathematics (4 per week). Of these, 21 teaching hours of geometry (or 15 %) in the fourth grade and 35 teaching hours (or 25 %) of geometry in the fifth grade. The fourth grade pupils learn about straight lines and circle in the plane. The fifth grade pupils learn about angles, circumference and area of rectangle and square, area and volume of cube and cuboid.

Table 2. Frequency of the teachers' responses related to the scheduled number of teaching hours in the curriculum for geometry.

		<i>N</i>		Number of teaching hours for geometry given in the curricula is appropriate.		
		subjects		yes	no	no answer
		count	<i>N</i> %	<i>N</i> %	<i>N</i> %	<i>N</i> %
Total		108	100 %	68.5 %	29.6 %	1.9 %
Level of education	2 year college	20	18.5 %	75.0 %	25.0 %	0.0 %
	4 year university degree	72	66.7 %	65.3 %	31.9 %	2.8 %
	Master or phd	16	14.8 %	75.0 %	25.0 %	0.0 %
Work experience	1–10 years	30	27.8 %	73.3 %	23.3 %	3.3 %
	11–20 years	53	49.1 %	66.0 %	32.1 %	1.9 %
	> 20 years	25	23.1 %	68.0 %	32.0 %	0.0 %
Grade you teach	First	28	25.9 %	67.9 %	32.1 %	0.0 %
	Second	22	20.4 %	68.2 %	31.8 %	0.0 %
	Third	22	20.4 %	59.1 %	40.9 %	0.0 %
	Fourth	26	24.1 %	73.1 %	23.1 %	3.8 %
	Fifth	10	9.3 %	80.0 %	10.0 %	10.0 %

When asked whether the number of teaching hours scheduled for geometry in the curriculum is appropriate, more than two-thirds of the respondents gave an affirmative answer (Table 2). According to the data in Table 2, there are no differences in the opinion about the number of teaching hours for geometry among the respondents according to the number of years of their work experience, their professional education, and the grade they teach.

As far as the curricula for mathematics restricted to the geometric content are concerned, 58.3 % of respondents are of the opinion that nothing should be changed, whereas 23 % of respondents believe that the number of teaching hours scheduled for the geometric content should be increased, but that the choice and distribution of geometric contents is appropriate to the age of the pupil. Here we will point out the opinion of one respondent who thinks that the geometric contents do not need to be studied before the second grade, i.e. before children reach the age of 7.

The surveyed teachers could indicate in the questionnaire which geometrical contents are difficult to teach for them and which are the contents the learners are most likely to adopt. This gives us a more complete picture of the teacher's opinion on the appropriateness of the geometric content to the pupil's age. The highest percentage represents those who stated that for them it was not difficult to teach anything (46.3 %). In addition, 12 % of respondents did not provide the answer, so we think they belong to the category of those who have no difficulties in teaching anything. Thus, approximately 60 % of the respondents said they had no difficulty in teaching geometric contents. Among the remaining 41.7 % of respondents, 10.2 % said it was difficult to teach the concept of volume and 9.3 % to teach the differences between solids and plane figures. The same percentage of respondents point out that it is difficult for them to teach drawing by using geometric accessories. In addition to this, teachers point out the difficulties in teaching the concept of area (7.4 % of respondents), the circumference (4.6 %) and the solids (4.6 %). On the other hand, 32.4 % of respondents believe that not a single content is a learning problem for pupils, while 7.4 % of them did not give any answer. This means that more than half of the respondents (exactly 60.2 %) consider that certain contents are difficult to learn for pupils. The most of the mentioned responses referred to differences between plane figures and solids (25.9 %), then drawing geometric figures (13 %), and concepts of circumference, area or volume (7.4 %).

Based on the answers of the surveyed teachers, we can say that most of the teachers declaratively support the number of teaching hours and the selection of the geometric teaching content, and besides, they emphasize that they do not encounter any difficulties in teaching geometric contents. On the other hand, the same percentage of respondents emphasize that pupils have difficulties in learning certain geometric contents.

4.2. The second research task

Textbooks serve teachers as a teaching tool, but also as an teaching aid in the teaching process. It is therefore important to find out what is the teachers' opinion

on the quality of textbooks used in the teaching practice, and within our scope of research, to discover the teacher's opinion about the quality of presentation of geometric contents in math textbooks.

The teachers who participated in the research were invited to describe the quality of the textbooks with grades from 1 (bad) to 5 (excellent). In order to determine which of the statistical data analysis test to apply, we first examined the normality of the distribution of results using Kolmogorov-Smirnov's and Shapiro-Wilkov's tests. The results of the above-mentioned tests showed that there was a statistically significant difference in relation to the results with normal distribution, and in the further analysis we used nonparametric statistics. We were interested in whether the teachers provided statistically significant different answers to certain questions about textbooks for five different grades (same respondents, but different questions), so we used Friedman's test bearing in mind the type of data. Thus, we investigated whether there were any differences between the respondents' responses to the questions about textbooks for five different grades.

Friedman's test ($\chi^2 = 14.635$; $df = 4$; $p = 0.006$) showed that teachers have different opinions about the quality of at least one of the textbooks from the first to the fifth grade. To research which textbooks have received a positive or negative review, we applied Wilcoxon's test scores with Bonferroni's correction, which allows us to avoid the type 1 errors over the limit value of 0.05. Based on the results of the Wilcoxon test for each pair of variables, we conclude that the only difference that has been statistically significant for the teacher's opinion about the quality of the textbook is the difference between the answers for the quality of textbooks for the fifth and third grades. Only this difference has the value of significance lower than our limit value ($Z = -3.242$; $p = 0.001$). This means that teachers have a more positive view of the quality of textbooks for the third grade than for the quality of textbooks for the fifth grade. None of the other differences is significant.

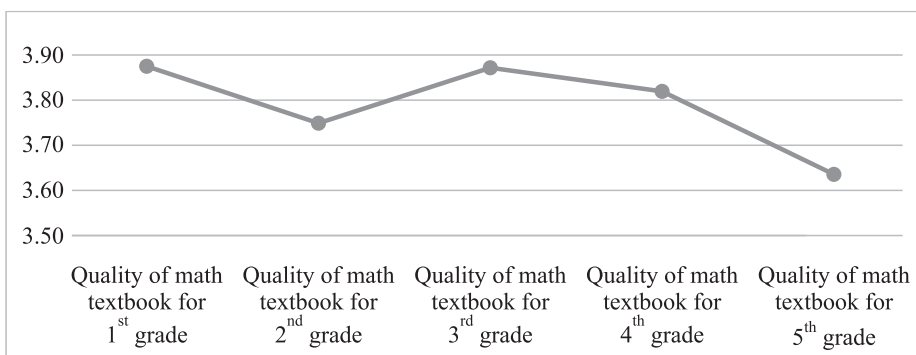

Figure 1. Graphic representation of the teacher's responses related to the quality of the textbook.

The teachers' responses to the quality of textbooks were illustrated by Figure 1. The graphic representation of the results shows that the teachers are least satisfied

with the quality of the textbooks for the fifth grade and then for the second grade. Their satisfaction over the remaining three grades oscillates in the interval of 0.1.

In the same way, we examined the teachers' views on the quality of presentation of geometric contents in textbooks. The Friedman test ($\chi^2 = 10.939$; $df = 4$; $p = 0.027$) shows that there is at least one statistically significant difference in the views on the quality of presentation of geometric contents in the textbooks, and the Wilcoxon test confirms that, according to teachers' opinions, the third and fifth grade textbooks differ significantly in the quality of presentation of geometric contents ($Z = -3.161$, $df = 4$). The respondents have a more positive view of the quality of presentation of geometric contents in the textbook for the third grade than in the fifth grade textbook. In other cases, the Wilcoxon test does not detect statistically significant differences. Figure 2 shows the teachers' answers on the quality of presentation of geometric contents in the textbooks.

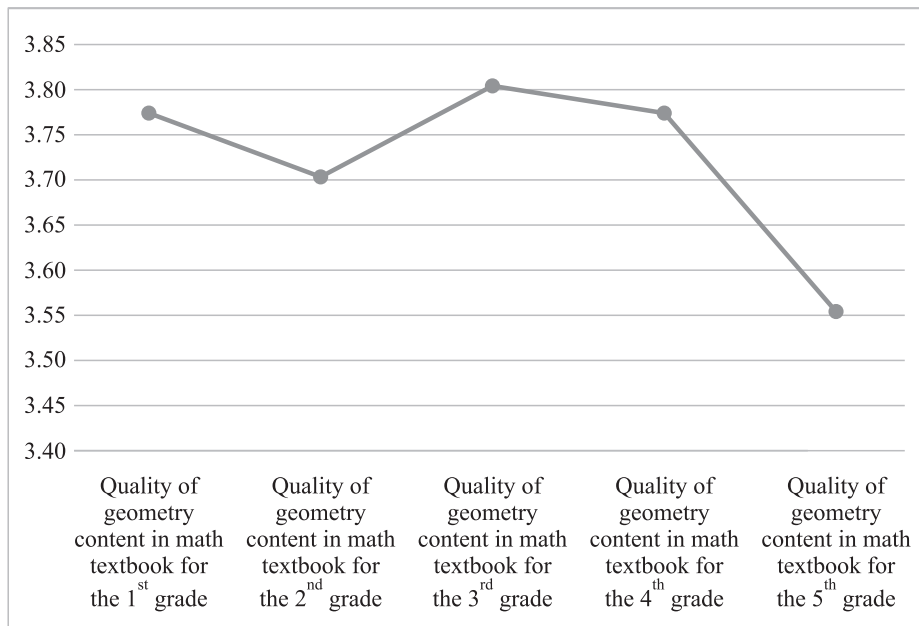

Figure 2. Graphic representation of teachers' responses related to the presentation of geometric contents in textbooks.

The teachers used grades 1 to 5 to assess the choice of geometric tasks in math textbooks as well. Once more, Friedman's test ($\chi^2 = 15.823$, $df = 4$, $p = 0.003$) shows that there is a statistically significant difference between at least two categories and Wilcoxon's test confirms that teachers have a more negative opinion on the selection of geometric tasks in the math textbooks for the fifth grade than in the textbooks for the second, third or fourth grade. We graphically presented the teachers' answers related to the choice of geometric tasks in math textbooks (Figure 3). According to the teachers' opinion, the worst one is the choice of geometric tasks in the textbook for the fifth grade, then in the textbooks for the first, second, fourth and third grades.

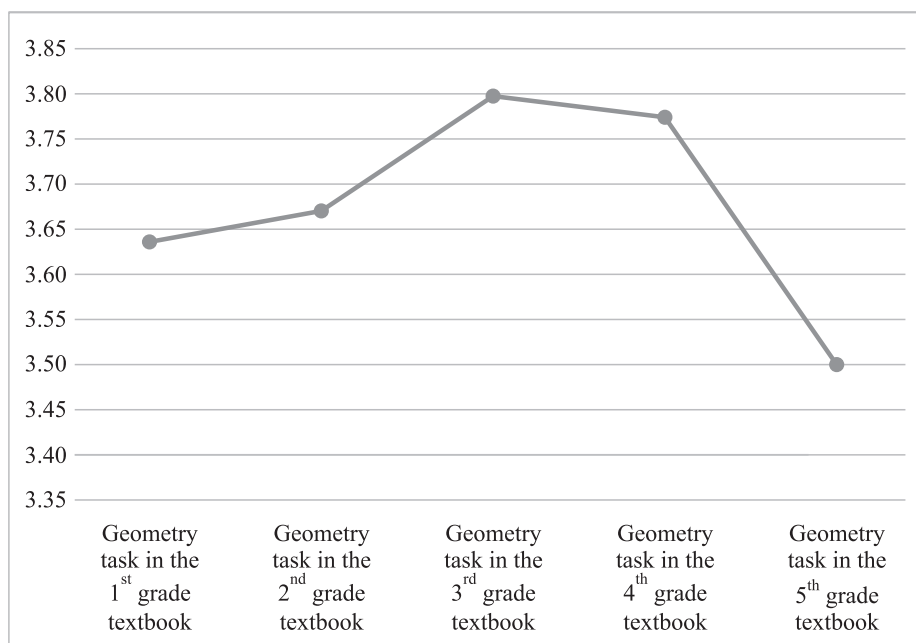

Figure 3. Graphic representation of teachers' responses related to the selection of geometric tasks in math textbooks.

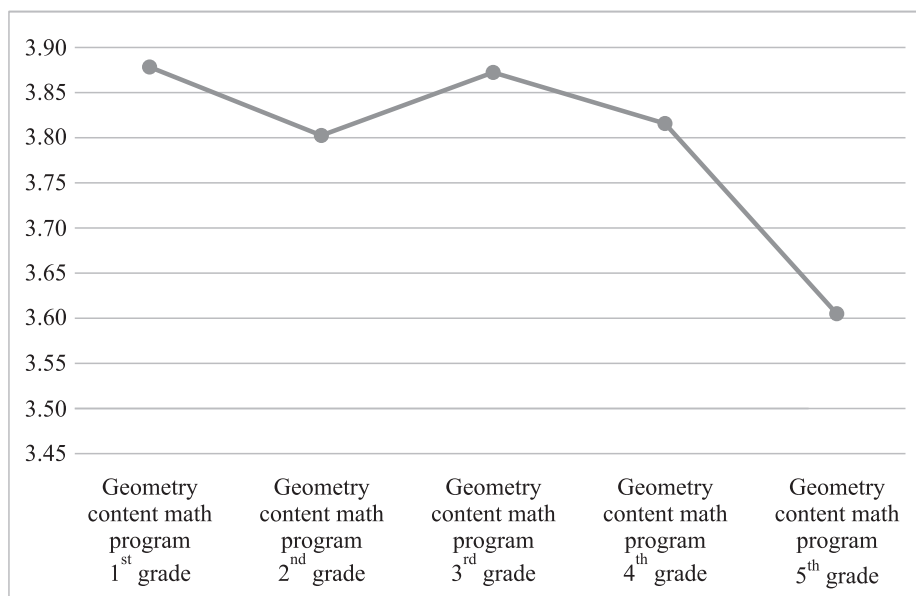

Figure 4. Graphic representation of the teachers' responses related to the curriculum.

Since math textbooks have to comply with the Curriculum, we asked the teachers to evaluate the schedule and scope of the geometric contents prescribed by the curriculum for each grade. Friedman's test ($\chi^2 = 18.865$, $df = 4$, $p = 0.001$) shows that there are statistically significant differences between at least two categories. The results of Wilcoxon's test show differences in the fifth grade again. In this case, there are statistically significant differences in the teachers' opinions about the geometric contents in the curriculum for the fifth grade compared to all other grades. The results listed above are illustrated by Figure 4.

The teachers expressed their opinions on the quality of textbooks used, particularly on the quality of the presentation of geometric contents in those textbooks, as well as on the scope and choice of geometric contents prescribed by the curriculum for the first five grades of primary school by using grades from 1 to 5. Graphic representations show average grades according to considered aspects which are placed between 3 and 4. If we should sum up all of the results we came up with, then we can notice that the teachers generally had the same or similar opinions for all the questions that were asked about a particular grade.

4.3. The third research task

With the third research task we wanted to determine whether the choice of methods of teaching geometric contents in the initial teaching of mathematics as well as the choice of forms of class organization of pupil work both depend on the level of education and the time teachers previously spent in teaching.

In this segment of the study as well, the same respondents participated in the survey. In the statistical analysis of the results, a chi square test was used to determine the dependence of the choice of teaching methods and forms of class organization of pupil work from the level of professional qualification and years of the respondent's experience. Within each of the independent variables, we identified three categories. Thus, according to the level of professional qualification, we distinguished between the respondents who completed college (two year study), faculty (faculty degree, 4 year study) and those who got the master's degree, and according to the years of work experience, we distinguished between teachers with less than 10 years of work experience, those with 10 to 20 years and those with more than 20 years of work experience. The chi square test results are shown in Table 3.

The chi square test values show that there is only one statistically significant difference ($\chi^2 = 7.716$, $p < 0.05$), when it comes to the level of professional qualification of the respondents and the choice of independent student work method (Table 3). The choice of independent work method depends on the level of professional qualifications of the respondents. The teachers who completed a college (two-year study) are more inclined to use the method of independent work than those who completed four-year or five-year studies.

Table 3. Dependency of the selection of teaching methods and forms of class organization of pupil work on the level of professional education and years of work experience.

	Level of education			Work experience		
	χ^2	Sig.		χ^2	Sig.	
Frontal work	4.647	0.098	$p > 0.05$	2.448	0.294	$p > 0.05$
Individual work	1.688	0.430	$p > 0.05$	1.918	0.383	$p > 0.05$
Individualized work	5.940	0.051	$p > 0.05$	0.897	0.639	$p > 0.05$
Work in pairs	0.792	0.673	$p > 0.05$	4.457	0.108	$p > 0.05$
Group work	1.386	0.500	$p > 0.05$	3.809	0.149	$p > 0.05$
Oral presentation method	0.527	0.768	$p > 0.05$	0.170	0.919	$p > 0.05$
Dialogue method	1.161	0.560	$p > 0.05$	4.046	0.132	$p > 0.05$
Method of independent work	7.716	0.021	$p < 0.05$	1.542	0.462	$p > 0.05$
Demonstration method	1.019	0.601	$p > 0.05$	0.834	0.659	$p > 0.05$
Illustration method	1.371	0.504	$p > 0.05$	0.489	0.783	$p > 0.050$
Writing method	2.194	0.334	$p > 0.05$	4.298	0.117	$p > 0.05$

5. Conclusion

By analyzing the teachers' views on the representation and appropriateness of geometric contents, we have found that the teachers' opinions are contradictory. Approximately two-thirds of the respondents believe that the number of teaching hours of geometry is appropriate to the student's age and they have no objection to geometric contents. They also point out in the same number that they have no difficulties in teaching geometric contents. These responses are in collision with the expressed opinion of the respondents that pupils have difficulties in learning geometric contents. Based on given answers, we find that the respondent teachers are not thinking about teaching and learning as a unique process. They see their teaching separate from the pupils learning process. Although the cause of difficulty in learning geometry may be poor motivation or poor previous knowledge, it is inevitable that learning difficulties also reflect on the teaching process itself and make it difficult. Therefore, it is justified to further examine the opinion of teachers, but also of students, for the issue of what causes difficulties in learning geometry.

The teachers expressed their opinions on the quality of textbooks used, and in particular on the quality of the presentation of geometric contents in the mentioned textbooks, as well as on the scope and choice of geometric contents prescribed by the curriculum for the first five grades of primary school. Assuming that the curriculum prescribes which geometric contents will be taught and that it gives learning goals, and also assuming that textbooks are a means of teaching and a

learning aid, we are of the opinion that these results suggest that teachers critically reflect on the presentation of geometric contents in math textbooks, while noticing certain inconsistencies and deficiencies in the representation of geometric contents in math textbooks, especially in the textbook for the fifth grade.

When it comes to the dependency of teaching methods and the forms of class organization of pupil work on the level of education and work experience, we have found that teachers who completed two-year studies are more likely to use the method of independent work than teachers who completed four-year or five-year studies. Since the method of independent work in class teaching is most often used for classes of written knowledge tests, this result could be an indicator that teachers who have completed a college actually more frequently check the knowledge of students.

References

- [1] BALL, D. L., HILL, H. C. AND BASS, H. (2005). Knowing mathematics for teaching: Who knows mathematics well enough to teach third grade, and how can we decide? *American Educator*, 29, 14–22.
- [2] BUSH, W. S. (1986). Preservice teachers' sources of decisions in teaching secondary mathematics. *Journal for Research in Mathematics Education*, 17(1), 21–30.
- [3] HILL, H. C. AND BALL, D. L. (2004). Learning mathematics for teaching: Results from California's Mathematics Professional Development Institutes. *Journal of Research in Mathematics Education*, 35, 30–351.
- [4] HILL, H. C., ROWAN, B. AND BALL, D. (2005). Effects of teachers' mathematical knowledge for teaching on student achievement. *American Educational Research Journal*, 42(2), 371–406.
- [5] LENHART, S. T. (2010). *The Effect of teacher pedagogical content knowledge and the instruction of middle school geometry (dissertation)*. Liberty Univesity: The Faculty of the School of Education.

Contact addresses:

Sanela Nesimović
Faculty of Educational Sciences, University of Sarajevo
Skenderija 72 Sarajevo, Bosnia and Herzegovina
e-mail: nesimovicsanela@hotmail.com

Karmelita Pjanić
Faculty of Pedagogy, University of Bihać
Luke Marjanovića b.b., Bihać, Bosnia and Herzegovina
e-mail: kpjanic@gmail.com; karmelita.pjanic@unbi.ba

Mišljenja učitelja o geometrijskim sadržajima zastupljenim u nižim razredima osnovne škole

Sanela Nesimović¹ i Karmelita Pjanić²

¹Pedagoški fakultet, Univerzitet u Sarajevu, Sarajevo, Bosna i Hercegovina

²Pedagoški fakultet, Univerzitet u Bihaću, Bihać, Bosna i Hercegovina

Sažetak. Da bismo imali što kvalitetnije obrazovanje, svaki njegov segment bi trebao biti maksimalno uređen. Bitnu kariku kvalitetnog matematičkog obrazovanja čine učitelji. Njihova uloga je nezamjenjiva: način na koji rade i kako razmišljaju o svom pozivu direktno utiče na rezultate njihovog rada, odnosno na ishode učenja kod učenika. Način i kvalitet njihovog rada zavisi od njihovog mišljenja (ili stava) prema preostalim segmentima matematičkog obrazovanja.

Cilj ovog rada je da istražimo mišljenja učitelja o geometrijskim sadržajima u kurikulumu za prvih pet razreda osnovne škole, o kvaliteti udžbenika matematike za prvih pet razreda, te mišljenja o nastavnim metodama koje se koriste pri poučavanju geometrijskih sadržaja. U tu svrhu anketirano je 108 učitelja iz 11 osnovnih škola Kantona Sarajevo.

Analizom rezultata anketiranja možemo primijetiti da su učitelji različitog obrazovnog nivoa i godina staža imali ista ili slična mišljenja za sva postavljena pitanja koja se odnose na zastupljenost geometrijskih sadržaja, kvaliteti udžbenika za određeni razred kao i odabiru i primjeni nastavnih metoda u procesu poučavanja geometrije.

Ključne riječi: geometrija, razredna nastava, mišljenje učitelja, udžbenik, nastavne metode

Geometric thinking of primary school pupils

Sanela Nesimović¹ and Karmelita Pjanić²

¹Faculty of Educational Sciences, University of Sarajevo, Sarajevo, Bosnia and Herzegovina

²Faculty of Pedagogy, University of Bihać, Bihać, Bosnia and Herzegovina

Abstract. According to Pierre van Hiele's theory of the levels of geometric thinking, there are five levels of geometric thinking: visualization, analysis, informal deduction, deduction and rigor. Those levels are not conditioned by one's age, but their order is unchangeable. On the other hand, the teaching of mathematics is characterized by the fact that pupils deal with various mathematical concepts adopted at different levels at the same time. Some of the concepts have been developed completely while the development of other concepts has remained at the level of mere perception.

In this paper, we propose an age-appropriate framework for reaching each of the van Hiele's levels, based on van Hiele's theory of geometric thinking and taking into account the document 'The Common Core Curricula for Mathematics Based on Learning Outcomes in Bosnia and Herzegovina'. The aim of this paper is to determine whether primary school pupils can identify the elements of different levels of geometric thinking according to van Hiele. For this purpose, a survey was carried out among 1889 primary school pupils (1st – 5th grade) from ten primary schools in Sarajevo Canton. For the purpose of testing, the diagnostic tests were created containing the tasks which detect the elements of the following levels: visualization, analysis, informal deduction.

The research results show that the levels of geometric thinking of primary school pupils generally fit into the suggested framework. In addition, it was noticed that pupils who achieve the level of visualization and analysis succeed in detecting causal relationships regarding the specific geometric content. The obtained results indicate that the transition from one level of geometric thinking to the next one does not happen suddenly.

Keywords: geometric thinking, primary school pupils, visualization, analysis, informal deduction

1. Introduction

Dutch educators of mathematics Dina and Pierre van Hiele created a hierarchical model that consists of five levels of geometric thinking. These levels can be taken as ways of understanding spatial concepts. The levels are numerated in numbers from 0 to 4:

level 0 – level of visualization,

level 1 – level of analysis,

level 2 – level of abstraction or informal deduction,

level 3 – level of deduction,

level 4 – level of rigor.

Based on further research, the number of those levels was changed as 1 to 5, and the level 0 represented the level of those who do not recognize the forms at all (Romano, 2009). In this paper, we will use a numeration of 0 to 4 for the levels of geometric thinking.

2. Theoretical background

Research results show that the levels are mutually conditioned (Burger & Shaughnessy 1986; Fuys, Geddes & Tischler, 1988). One cannot skip a certain level. One also does not have to reach each level. Geometric experience is the most important factor that influences progression through levels. According to van Hiele, development solely depends on efforts to acquire new knowledge and it can happen at any time in life. Development should not be accelerated (Clements, Battista, 1992). If teaching is at a higher level than the one in which the pupils are, then the gap in communication is generated. Most of high school teachers think on the third or fourth level when they teach, and pupils enrolling in the first grade of secondary school are on the first or second level (Mason, 1998). Studies have shown that after completing primary education it is desirable for pupils to reach the level of informal deduction (Usiskin, 1982; Burger & Shaughnessy, 1986; Pjanić-Lipovača, 2014).

Bearing in mind the document of *The Common Core Curricula for Mathematics Based on Learning Outcomes in Bosnia and Herzegovina* (2015), in Table 1 we briefly present each of the levels, specifying its basic characteristics and typical examples according to the age of the pupil.

Table 1. Basic characteristics of van Hiele's levels of geometric thinking.

Level	Description	Levels in grades	Characteristics	Examples
0	visualization	from preschool age to the 2 nd grade of primary school	Pupils recognize shapes when they see them.	"It's a square because it looks like a square."
1	analysis	from the 3 rd grade to the 5 th grade of primary school	Pupils recognize figures in relation to their properties.	"Squares have four sides, four right angles, their opposite sides are parallel to each other."
2	informal deduction	from the 6 th grade to the 9 th grade of primary school	Pupils establish good relationships between and within the properties; they can form abstract definitions; there is a greater chance to engage in "if-then" thinking.	All squares are rectangles, but all rectangles are not squares.
3	deduction	secondary school	Pupils prove theorems deductively; they are able to use abstract statements on geometric properties and make conclusions based more on logic than on intuition.	Based on a series of deductive elements, pupils can prove that the diagonals of a rectangle are mutually split in halves.
4	rigor	faculty	Pupils understand the relationships between different geometric systems; they can compare, analyze and find evidence within different geometric systems.	Spherical geometry is based on lines drawn in the sphere, not in the plane or in a "plain" space.

The quality of teaching mathematics (and thus geometry) is that the pupils meet and deal with concepts at different levels of knowledge at the same time. Namely, in math classes we often encounter the following situation: pupils familiarize themselves with a new concept (they first hear about the concept), some concepts are just recognized (in their symbolic or visual form), whereas some concepts and procedures are applied and analyzed. It is therefore possible for second-grade pupils to express the geometric thinking of level 1 in the domain of certain (but not all) geometric contents. Also, primary school pupils succeed in catching causal relationships within some geometric contents.

3. Methodology

Bearing in mind the characteristics of the geometric thinking levels, and taking into account the real abilities of the pupils in a certain age and the extent of the contents they study within the regular teaching course, we have created four tasks, which we grouped into the diagnostic tests for the first five grades of primary school. We have designed and ranked the tasks as follows:

- Task of level 0: to solve the task, pupils should observe the visual characteristics of the object as a whole,
- Task of level 1: pupils have to do an analysis, i.e. they need to imaginatively divide into parts the default objects in order to reach the solution of the task,
- Task of level 1+: pupils have to imaginatively divide into parts the default objects and spot the causal relationships between the objects in the task,
- Task of level 2: pupils have to apply a certain form of informal deduction in order to solve the given task, i.e. pupils are asked to provide an explanation of their answer.

It should be emphasized that if the pupil solves the task of level 1+ or 2, this does not mean that he is at level 1 or 2 geometric thinking according to van Hiele, but it rather suggests that the pupil is able to perceive certain causal relationships and that he is able to justify his actions solely for the geometric concepts to which the assigned task relates.

The aim of this research is to examine whether the elements of different geometric thinking levels according to van Hiele can be identified in pupils of the lower grades of primary school. We conducted a survey among 1889 pupils from the first to the fifth grade of ten primary schools in Sarajevo Canton, namely 487 first-grade pupils, 415 second-grade pupils, 420 third-grade pupils, 401 fourth-grade pupils and 163 fifth-grade pupils. We analyzed each test separately. We wanted to examine whether geometric thinking of the pupils of the lower grades in primary school is at a satisfactory level. We will outline the most significant results below.

4. Results and discussion

Pupils of each grade solved four tasks designed to meet the 0, 1, 1+ and 2 level criteria described in the previous section. The content of the tasks was fully aligned with the curricula for each grade. In the analysis of the results by grade, we will describe the tasks for each grade. In order to determine which pupils achieve better results at a certain level, we have shown them in the table with mean values (Table 2).

Table 2. Mean value for the success in task solving.

	1 st grade	2 nd grade	3 rd grade	4 th grade	5 th grade
	Mean	Mean	Mean	Mean	Mean
Task 1	8.14	8.8	7.95	1.88	5.34
Task 2	6.38	4.21	7.56	9.01	7.21
Task 3	5.12	8.19	3.52	5.97	0.77
Task 4	6.13	3.76	7.93	3.73	1.41

The mean values are calculated on a scale from 1 to 10 for each task. After having insight into the data in Table 2, we conclude that the mean value of success in solving the tasks of a given type did not increase with the pupil's grade. This suggests that higher grade pupils are not necessarily more successful in solving the type of task that requires the engagement of the same thinking operations. The same conclusion is reached by taking into consideration the total scores awarded to pupils of each one of the grades in solving tasks of a particular type.

The total score that the pupils achieved by solving each one of the tasks by grades converted into the scale from 1 to 10 is shown in Figure 1.

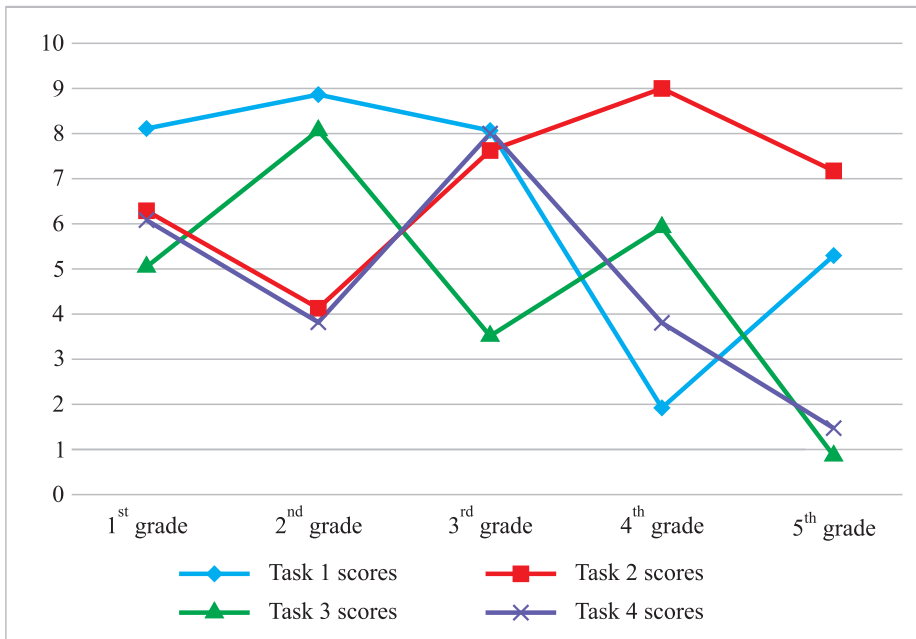

Figure 1. Comparing scores between grades.

The most striking thing in Figure 1 are the maximum and minimum values. In our case, they mean that fourth-grade pupils were the best in completing the second task (level 1) in comparison to the others, and that fifth-grade pupils were the worst in completing the fourth task (level 2). With respect to the requirements of the given tasks in the sense of the pupil's engagement in thinking and that the tasks were ordered according to their difficulty level, it was expected that the pupils of all grades would be most successful in solving the first task (level 0). It was also expected that success in solving tasks of level 1, 1+ and 2 increases in each higher grade. However, Figure 1 denies the above mentioned expectations.

4.1. The analysis of test scores for the first grade

This test consists of four tasks divided by the carefully created levels described in the previous section. By content, all tasks are in accordance with the curricu-

lum for mathematics in the first grade. In the first task, pupils were expected to correctly identify plane figures and solids (level 0). As for the second task, they were expected to recognize the shape of the cuboid and the shape of the ball in the set of offered items from everyday life (level 1). In the third task, they were expected to be able to make the classification of the offered shapes to the classes of geometric figures that they had learned so far. Among the offered shapes, there were also plane figures that the pupils had not learned about before and that they were probably not able to name. These shapes can be classified in a number of ways by pupils (e.g. they have not learned them yet or according to some of the traits these shapes have) (level 1+). In the fourth task, pupils were expected to recognize a feature shared by all the offered figures, and to specify that feature as well (level 2).

The total number of respondents – pupils of the first grade was 487. After having insight into the achieved results, we can conclude that the pupils solved the tasks at the level of visualization (Figure 1, Table 2). A certain percentage of pupils were able to make an analysis and make certain conclusions, but on the basis of only 4 completed tasks we cannot conclude that the level of geometric thinking of these pupils is higher than level 0. With respect to the curriculum for the first grade, it is justified to conclude that the scores of the mentioned number of pupils are the result of proper teaching and learning of geometry.

By qualitative analysis of test scores for the 1st grade, in 145 pupils (out of a total of 487 pupils), i.e. in 29.77 % of respondents, we noticed certain responses that we thought were suitable to be further commented on. Even 12.8 % of respondents do not differentiate between a cube and a square, while 9.4 % of them misspell the word “geometry” and its derivatives, 5.5 % of them do not distinguish between the ball and the circle, 3.9 % of the pupils do not observe the terms of the task, whereas 2.6 % of pupils do not distinguish between triangles and pyramids, and 1.2 % of them do not distinguish between triangles and squares, or triangles and rectangles. These results point to the possibility that the pupils did not achieve the level of visualization in the development of geometric thinking. The development of geometric concepts should receive much more attention and the approach to studying these contents should be methodologically adapted in a way that we include more activities of perceiving geometric shapes not only while teaching geometric contents, but also while teaching contents about numbers and measures.

4.2. The analysis of test scores for the second grade

This test consisted of four tasks arranged according to carefully created levels and which were consistent with the content of the proposed curriculum for the second grade. In the first task, pupils had to properly name the illustrated lines (level 0). The second task was to determine the accuracy of the given statements (level 1). In the third task, the most common shapes of the house and the roof of the house were to be identified (level 1+). In the fourth task, pupils had to recognize which of the offered figures have a common feature that they can roll and they had to explain their answer (level 2).

The total number of respondents was 415. The pupils' achieved scores show that the level of visualization still dominates among the pupils of the second grade (Figure 1, Table 2). Only a quarter of the respondent pupils showed the skill of analyzing and making conclusions (informal deduction) within the curriculum contents for the second grade. Assuming that the pupils solved a single task which, by definition, requires a certain level of geometric thinking, it cannot be concluded that the level of geometric thinking exceeds the level of visualization but we may consider that, within the content prescribed by the curriculum for the second grade, these pupils can apply the thoughtful operations that exceed the level 0 of geometric thinking.

By qualitative analysis of the obtained results, we noticed that 8.2 % of the second grade pupils considered that the roof of the house was in a triangular shape, and 9.9 % of them did not answer the reasons for the possibility of rolling or not-rolling of geometric plane figures and solids. Only 0.2 % of respondents mistakenly used the terms edge and side, which is an encouraging result because it is a widespread practice noticed in schools that one does not take care of the meaning of these terms and they are mainly used as synonyms, which is wrong.

4.3. The analysis of the test scores for the third grade

The test for the third grade consisted of four tasks ordered according to the described levels. By content, all the tasks were aligned with the curriculum for the third grade. In the first task, pupils were asked to identify and classify the displayed geometric bodies according to the type of their surface (level 0). The second task was to indicate how many flat surfaces and how many curved surfaces there were, and also how many edges and how many vertices there were in the named geometric bodies (level 1). In the third assignment, pupils were supposed to identify amongst the specially highlighted points which ones are common for the given figures (level 1+). In the fourth task, they were expected to recognize which cuboid the drawn net belongs to (level 2).

The study included 420 third-grade pupils. By analyzing and comparing the scores achieved on individual tasks, we can see that the third-grade pupils still rely on visualization (Figure 1, Table 2). Namely, the task of analyzing geometric bodies was not done at a satisfactory level. Similarly, a large number of pupils were unable to spot common points of multiple plane figures in the picture. Good results in the 4th task do not imply that the pupils have overcome the level of visualization but they can actually suggest how to choose examples of geometric tasks that can enhance the development of geometric thinking.

By qualitative analysis of responses, we have noticed the characteristic errors in 54 pupils, or in 12.86 % of the total number of third-grade pupils surveyed. The largest percentage, 44.5 % of the pupils in the mentioned group do not differentiate between the terms of a ball and a circle, and they account for 5.8 % of the total number of third-grade pupils surveyed. The same percentage of pupils does not differentiate a square from a cuboid, while 33.5 % of the pupils in the group who make characteristic mistakes, or 4.2 % of the total number of respondents attending

the third grade, do not notice the difference between the term of a rectangle or a cuboid. Among the pupils who make characteristic mistakes, 5.6 % of them do not differentiate between the pyramid and the triangle, and they represent 0.7 % of the total number of respondents. If we take into account the type of these mistakes, then we see that pupils actually have problems with the distinction between plane figures and solids. So, by analyzing their responses, we came to the conclusion that they identify the geometric body as a whole with only one part of it, or only one side of it. What we cannot ignore is the total percentage of such pupils. Also, it is important to note that in all these cases, there is not one, but two or three mistakes done by a certain number of pupils (26.1 % of respondents, or 3.3 % of the total number of respondents), which may imply that mistakes are not a result of imprudence or lack of attention, but of ignorance. In addition to the above mentioned, one peculiarity is that 1.9 % of pupils found that there are several types of pyramids, so it was mentioned by them in the second task. They differentiated between triangular and quadrilateral pyramids. Since only quadrilateral pyramids are shown in the textbooks, these answers can lead to a higher level of geometric thinking.

4.4. The analysis of the test scores for the fourth grade

This test consisted of four tasks ranked according to the previously described levels and consistently aligned with the curriculum for the fourth grade. In the first task, pupils had to count straight line segments and triangles on given figures (level 0). The second task was to determine which relationships are valid among the given straight lines (level 1). In the third task, pupils were supposed to determine how many lines can be drawn through one, two, or three given points, and then to make a sketch of each one of these cases (level 1+). In the fourth task, they were expected to count how many small cubes make a given figure, then sketch out how this figure looks like when viewed from three perspectives (level 2).

401 fourth-grade pupils participated in the study. Their responses to Tasks 2, 3 and 4 point to the fact that they are able to see parts of the figure and relationships among them, as well as relationships between the figures, which, on the other hand, is in collision with the scores of the 1st task which was the simplest and which did not require nothing more than recognizing the figures on the basis of their appearance (Figure 1, Table 2).

Based on the qualitative analysis, we have come up with some other important facts. Namely, 7.7 % of respondents indicate that they perceive infinity as the finite number. Additionally, 5.2 % of pupils have drawn two-dimensional images as three-dimensional ones, and it leads us to assume that, in the case of these pupils, there is a problem in the perception of space and plane and in understanding their interrelationships.

4.5. The analysis of the test scores for the fifth grade

The test for the fifth grade consisted of four tasks ranked according to the levels described. All tasks were aligned with the curriculum for the fifth grade. In the first task, pupils had to visualize the sharp and right angles in the picture (level 0). In the second task, they had to supplement the statements about the square and the cube (level 1). The third task was to imaginatively arrange 100 matching little squares in order to get the figure of the smallest or the largest circumference. The answer should have been explained (level 1+). In the fourth task, pupils were supposed to supplement the statements that connect rectangles and squares, respectively cubes and cuboids (level 2).

The study involved 163 fifth-grade pupils. The results of the research indicate the possibility that among the fifth-grade pupils there are those who have not reached the level of geometric thinking appropriate to that age (Figure 1, Table 2). A significant number of pupils had problems in solving tasks that belonged to van Hiele's zero and first level of geometric thinking. On the other hand, it is encouraging to notice the pupils who have successfully solved the task of the second level.

By qualitative analysis of pupil responses we did not notice specific errors or unexpected conclusions. It should be noted, in particular, that 3.1 % of the pupils, instead of answering the question asked, stated that they had not previously solved similar tasks.

5. Conclusion

In the previous section, we presented the results of the first to fifth grade pupils achieved by solving tasks tailored to their age, and selected and ranked in a way that they rely on the characteristics of the levels of geometric thinking according to van Hiele. Bearing in mind that pupils of the age up to the fifth grade can only reach the initial two levels of geometric thinking in reality (level of visualization and level of analysis), while the notions of the third level (informal deduction level) occur only in a particular pupil, the tasks were designed so that they required pupils to notice and identify geometric objects on the basis of their appearance (level 0), to analyze the geometric objects and to notice their components (level 1), to link the properties of geometric objects (level 1+) and to make certain conclusions and provide explanation (level 2). Given that the pupils of each grade solved only one of the tasks of each level, this is not enough to determine the quality of the geometric thinking of the pupils, but the results may point to problems in understanding the geometric contents.

Summing up the results, we came to the conclusion that there are significant differences in the success in solving each task among grades, but at the same time, the success in solving the task of a particular level did not always increase with the higher grade. Thus, we cannot conclude that in time, our pupils improve certain characteristics of geometric thinking. Likewise, the success in solving the test is

worst in the fifth grade. Causes can be in the formalization of teaching, without the engagement of visualization, and in particular the engagement of thoughtful analysis and synthesis operations, and the absence of conclusions and explanations.

The obtained results of the surveyed pupils of the lower grades of primary school indicate the existence of problems related to the understanding of geometric contents at all levels and in all grades. Since the pupils were not solely asked for the factual knowledge and mere reproduction of the taught contents, but also for the engagement of the thoughtful operations and making conclusions, the results suggest that the geometric thinking of pupils of the lower grades of primary school is not at a satisfactory level.

References

- [1] BURGER, W. F. AND SHAUGHNESSY, J. M. (1986). Characterizing the van Hiele levels of development in geometry. *Journal for Research in Mathematics Education*, 17, 31–48, NCTM.
- [2] CLEMENTS, D., BATTISTA, M. (1992). Geometry and spacial reasoning. in D. Grouws (Ed.), *Handbook of research on mathematics teaching and learning*, 420–464, New York: Macmillian Publishing Company.
- [3] DŽUMHUR, Ž., ZUBAC, I., LIPOVAČA-PJANIĆ, K., PRIBIŠEV BELESLIN, T. (2015). *Zajednička jezgra nastavnih planova i programa za matematičko područje definisana na ishodima učenja*. Mostar: Agencija za predškolsko, osnovno i srednje obrazovanje.
- [4] FUYS, D., GEDDES, D. AND TISCHLER, R. (1988). The van Hiele model of thinking in geometry among adolescents. *Journal for Research in Mathematics Education Monograph 3*, Reston, VA: National Council of Teachers of Mathematics.
- [5] MASON, M. (1998). The van Hiele Levels of Geometric Understanding. *Professional Handbook for Teachers, Geometry: Explorations and applications*, McDougal Littell Inc.
- [6] PJANIĆ-LIPOVAČA, K. (2014). *Opšta metodika matematičkog obrazovanja*. Bihać: Pedagoški fakultet.
- [7] ROMANO, D. (2009). Van Hiele-ova teorija o učenju geometrije. *Metodički obzori*, 4, 1–2, 95–103.
- [8] USISKIN, Z. (1982). *Van Hiele levels and achievement in seconndary school geometry*. Chicago: The University of Chicago.

Sources

Službeni glasnik BiH, Br. 77/15, 5.10.2015.

Nastavni plan i program za prvi razred devetogodišnje osnovne škole (2017), Ministarstvo za obrazovanje, nauku i mlade Kantona Sarajevo.

Nastavni plan i program za drugi razred devetogodišnje osnovne škole (2017), Ministarstvo za obrazovanje, nauku i mlade Kantona Sarajevo.

Nastavni plan i program za treći razred devetogodišnje osnovne škole (2017), Ministarstvo za obrazovanje, nauku i mlade Kantona Sarajevo.

Nastavni plan i program za četvrti razred devetogodišnje osnovne škole (2017), Ministarstvo za obrazovanje, nauku i mlade Kantona Sarajevo.

Nastavni plan i program za peti razred devetogodišnje osnovne škole (2017), Ministarstvo za obrazovanje, nauku i mlade Kantona Sarajevo.

Contact addresses:

Sanela Nesimović
Faculty of Educational Sciences, University of Sarajevo
Skenderija 72 Sarajevo, Bosnia and Herzegovina
e-mail: nesimovicsanela@hotmail.com

Karmelita Pjanić
Faculty of Pedagogy, University of Bihać
Luke Marjanovića b.b., Bihać, Bosnia and Herzegovina
e-mail: kpjanic@gmail.com; karmelita.pjanic@unbi.ba

Geometrijsko mišljenje učenika razredne nastave

Sanela Nesimović¹ i Karmelita Pjanić²

¹Pedagoški fakultet, Univerzitet u Sarajevu, Sarajevo, Bosna i Hercegovina

²Pedagoški fakultet, Univerzitet u Bihaću, Bihać, Bosna i Hercegovina

Sažetak. Prema van Hieleovoj teoriji o nivoima geometrijskog mišljenja, postoji pet nivoa geometrijskog mišljenja: vizualizacija, analiza, neformalna dedukcija, dedukcija i strogost. Ti nivoi nisu uslovljeni godinama starosti, ali njihov poredak je nepromjenljiv. S druge strane, nastavu matematike karakteriše to da učenici u isto vrijeme barataju različitim matematičkim pojmovima koji su usvojeni na različitim nivoima. Neki od pojmova su razvijeni u potpunosti dok je razvoj drugih pojmova ostao na nivou same percepcije.

U ovome radu predlažemo jedan uzrasno prikladni okvir za dostizanje svakog od van Hieleovih nivoa, zasnovano na van Hieleovoj teoriji geometrijskog mišljenja i uzimajući u obzir dokument 'Zajednička jezgra nastavnih planova i programa za matematiku bazirano na ishodima učenja za Bosnu i Hercegovinu'.

Cilj ovog rada je ustanoviti da li se kod učenika razredne nastave mogu identifikovati elementi različitih nivoa geometrijskog mišljenja prema van Hieleu. U tu svrhu provedeno je istraživanje među 1889 učenika osnovne škole (od 1. do 5. razreda) iz deset osnovnih škola Kantona Sarajevo. U cilju ispitivanja kreirani su dijagnostički testovi, koji sadržavaju zadatke koji otkrivaju elemente sljedećih nivoa: vizualizacija, analiza, neformalna dedukcija.

Rezultati istraživanja pokazuju da nivoi geometrijskog mišljenja kod učenika razredne nastave generalno odgovaraju predloženom okviru. Osim toga, uočeno je da učenici koji dosegnu nivo vizualizacije i analize uspijevaju da uviđaju kauzalne odnose u pogledu specifičnog geometrijskog sadržaja. Dobiveni rezultati ukazuju na to da se prelazak s jednog nivoa geometrijskog mišljenja na sljedeći ne odvija u naglim skokovima već kontinuirano.

Ključne riječi: geometrijsko mišljenje, razredna nastava matematike, vizualizacija, analiza, neformalna dedukcija

3.

The role of mathematics textbooks and mathematics teacher resources

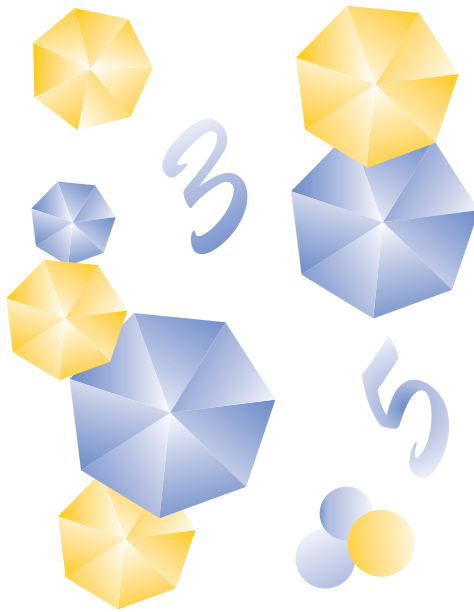

The influence of teacher guides on classroom practice

Ljerka Jukić Matić¹ and Dubravka Glasnović Gracin²

¹Department of Mathematics, University of Osijek, Osijek, Croatia

²Faculty of Teacher Education, University of Zagreb, Zagreb, Croatia

Abstract. Textbooks and the accompanying teacher guides are recognized as important and influential resources in mathematics education. Teachers rely heavily on the textbook for planning and enacting their lessons: they prepare lessons according to the textbook structure, teach new content according to the textbook, and use the textbook as a source of practice exercises and homework. This study focuses on the role of teacher guides in teacher's classroom practice and their influence on the textbook use. The study also focused on the issue about how teachers change the utilization of textbooks in the classroom when the teacher guides undergo changes in their content and structure. Although the results showed relative stability of teaching practice, we detected an educative impact of teacher guides because their content influenced the use of active teaching methods in the classroom.

Keywords: classroom practice, longitudinal study, teacher, textbook, teacher guide

1. Introduction

The International Association for the Evaluation of Educational Achievement (IEA) and the Trends in International Mathematics and Science Study (TIMSS) developed a tripartite model of the curriculum as a “starting point for the model of educational opportunities in school mathematics and science” (Valverde, Bianchi, Wolfe, Schmidt & Houang, 2002, p. 5). These three dimensions involve the intended, implemented and attained curriculum. The intended curriculum refers to intentions, aims, and system goals; the implemented curriculum involves instruction and practice activities, and the attained curriculum refers to knowledge and achievement. In this model, textbooks and teacher guides play an important role as mediators between the intended and implemented curriculum. On one hand, textbooks follow the requirements of the intended curriculum and, on the other hand,

they are designed as “templates for action” in classrooms (Valverde et al, 2002, p. 12). Because of this mediating role, Valverde et al. (2002) offered a modified model by embedding a fourth component: the potentially implemented curriculum as a link between the intended and implemented curriculum. The potentially implemented curriculum involves textbooks and other organized resource materials which “translate policy into pedagogy” (Valverde et al, 2002, p. viii). Since the teacher guides follow the curriculum outlines and provide information and materials about concrete actions of teaching and learning, they can be considered as the potentially implemented curriculum resources.

According to Pepin, Gueudet & Trouche (2013), mathematics teaching resources are all resources which are developed and used by teachers or students in their interaction with mathematics in and for teaching and learning, inside and outside the classroom. Adler (2012) introduced a broad conceptualization of resources in mathematics teaching- besides material resources, the author included cultural and teachers’ resources. A consequence of such a view is that teachers and resources interact in a participatory relationship where both the characteristics of the teacher and the characteristics of the resources influence the outcomes in classroom practice (Brown, 2009; Remillard, 2005).

The area of utilization of curriculum resources is important for our expectations about what can be accomplished in the classroom. They can promote a teacher’s pedagogical design capacity, or a teacher’s ability to use personal resources to adapt the curriculum materials and to achieve productive and beneficial instructional episodes in the classroom (Ball & Cohen, 1996; Davis & Krajcik, 2005; Ahl, Gunnarsdótti, Koljonen & Pálsdóttir, 2015). Further, curriculum resources can support the teacher’s pedagogical content knowledge, help them in the lesson design, suggest tasks, formative assessment and homework and organize individualized teaching, etc. (Davis & Krajcik, 2005). Remillard (2000) and Brown (2009), as well as Davis and Krajcik (2005), have studied the possible impact of curriculum materials and found that they offer a potential for designing educative support for teachers.

This paper attempts to investigate the interaction between the mathematics teacher and curriculum resources, focusing on the teacher guide and its influence on textbook use. We also try to investigate if and how the teacher changes his/her teaching practice if the publisher modifies the teacher guide.

2. Literature review

In this section, we provide a brief overview of the research on the utilization of mathematics textbooks and teacher guides.

Fan (2013) considers the textbook as an intermediate variable in the research, which is affected by independent variables and which affects the dependent variables. This means that the textbook is influenced by other factors and that the textbook itself influences the instruction. The mathematics textbooks can be analyzed according to different parameters: role of textbooks, textbook analysis and

comparison, textbook use and other areas (Fan, Zhu & Miao, 2013). One of the important issues is to find and understand how teachers interact and use textbooks in various countries. Studies found that many teachers prepare their lessons according to the textbook, use it for teaching new content, assign practice exercises and homework from the textbook (e.g. Pepin & Haggarty, 2001; Johansson, 2006; Zhu & Fan, 2002). This means that textbook content influences teaching. In their research on textbook use in England, Germany and France, Pepin and Haggarty (2001) detected a mediatory role of the teacher in mathematics education. The teacher was the one who decided which textbook to use, when and how it is used, which parts to use and in what order.

Another interesting issue is related to investigating how the textbook changes the teacher's practice. For instance, in their study about teachers using a reform-oriented textbook, Remillard and Bryans (2004) detected stability in teachers' patterns of curriculum use, but the authors also observed changes in the two teachers' practice who adopted the materials most comprehensively. Nicol and Crespo (2006) investigated how four Canadian pre-service teachers interpreted and used the textbooks while learning to teach. Through stumbling across various pedagogical, curricular and mathematical obstacles when using the textbook for lesson planning, their understandings of textbook use was challenged and changed during and after their classroom practice.

Since teachers' planning for lessons directly influences the instruction in the classroom, it is important to study, besides textbooks, other sources of potentially implemented curriculum. One of them is surely the teacher guides, which are "heavily used for preparing mathematics lessons" (Rezat, 2014, p. 401) and "they seem to play a major role for teachers in planning and carrying out their teaching" (Grevholm, 2014, p. 260).

Van Steenbrugge and Bergqvist (2014) investigated the form of address of six of teacher guides from the US, Belgium and Sweden. Their work served as basis in another study (Remillard, Van Steenbrugge, & Bergqvist, 2014) which analyzed the voice in the curriculum resources from the aspect of cultural context. That study detected diversity in the support that curriculum programs offer to the teachers showing differences in educational traditions among the countries investigated.

The research on the use of Icelandic teacher guides showed that the structure and content of the teacher guide influence how teachers think of and prepare their teaching (Gunnarsdóttir & Pálsdóttir, 2014). Similarly, the research conducted by Hoelgaard, Hemmi and Ryve (2014) focussed on the teacher guides and the classroom practice they construe. The results show that the teacher plays a central role in all three guides examined. They all provide support to teachers in forming their classroom practice, but in different ways. These studies contribute to the understanding of teacher guides as curriculum resources.

Remillard and Bryans (2004) showed that teachers' orientations toward curriculum materials and their professional experience may influence their way of using textbooks. Similar findings were reported in Rezat (2014), noticing that the more experienced teacher relied to a lesser extent on the teacher guide compared

to the more intensive use of the younger colleague. Similarly, the results on using teacher guides as support and inspiration for teaching in Sweden (Ahl, Koljonen & Hoelgaard, 2014) show that less experienced teachers rely more on the content in the teacher guide, using it as a toolbox as well as a resource for teacher learning. Their more experienced colleagues use the teacher guides for support and in the design of teaching. “Common for all teachers, despite prior experience, is that they want the teacher guide to provide connections between theory and practice” (Ahl et al., 2014, p. 153).

The overview of textbooks and teacher guides points to their importance as artefacts and resources of the potentially implemented curriculum. Since the above-mentioned studies on teacher guides mainly refer to US and Nordic authors, in the next section we present the research on textbooks and their accompanying teacher guides in Croatia.

2.1. Research on textbooks and teacher guides in Croatia

In Croatia, mathematics textbooks are compulsory in primary and secondary education. The Ministry of Education, Science and Sports provides a list of approved textbooks and teachers jointly select textbooks for their school for the period of four years. Along with the selected textbook, the publishers and textbook authors provide a corresponding teacher guide with every mathematics textbook, which contains guidelines for instruction. The Act on textbooks for primary and secondary education (Official Gazette of the Republic of Croatia 117, 2001) mentions the teacher guide as an obligatory book which supports the textbook (Article 2) and is in line with the national educational standards and goals (Article 6). The teacher guide contains information on “the possibilities of textbook use in the classroom, but it does not prescribe the procedures or limit the teacher’s creativity while planning the teaching process” (Official Gazette of the Republic of Croatia 69, 2003, Article 1). In 2006, the new Act on textbooks for primary and secondary education was adopted (Official Gazette of the Republic of Croatia 36, 2006). It does not mention teacher guides, but publishers continue to provide teacher guides alongside their textbooks.

A historical overview of the concern about textbook issues in Croatia is given in Glasnović Gracin (2014). The large-scale study reported in Glasnović Gracin and Domović (2009) investigated nearly one thousand Croatian mathematics teachers on the utilization of mathematics textbooks in lower secondary education in Croatia (grades five to eight). The teachers were examined using a questionnaire with a modified Likert scale with four degrees: never, seldom, often, and almost always. Also, several questions involved selecting one or more given answers. The results show that teachers use textbooks to a great extent for various activities: lesson preparation, teaching a new topic, exercising and assigning homework and that textbooks were used more than other curriculum resources. Around 52 % of surveyed teachers claimed they almost always use the textbook for lesson preparation and additional 45 % do so often; 97 % confirmed that they use the textbook as a source of mathematics exercises (51 % almost always and 46 % often); 99 %

of participants stated that they use textbooks for giving homework (74 % almost always and further 25 % often). The results show a strong reliance on the officially approved textbooks in Croatian mathematics education.

The results indicate that the classroom practice relies considerably on the textbook content and structure. Therefore, the content and structure of Croatian mathematics textbooks was analyzed, too (Glasnović Gracin, 2011). The findings point to the predominance of operation activities on the reproductive or simple-connections level with intra-mathematical content (i.e. symbolic exercises without context). These results showed that Croatian textbooks place more emphasis on algorithms and the view of mathematics as a tool rather than as a medium of communication (Heymann, 1996). The content analysis also showed that the requirements of the intended curriculum match the ones in the textbooks, thus the Croatian mathematics textbook can be perceived as a 'conveyor of the curriculum' (Fan et al., 2013, p. 635).

As an extension of the quantitative large-scale study, Glasnović Gracin and Jukić Matić (2016) investigated the use of textbooks with 12 lower secondary mathematics teachers. This qualitative study involved on-site observations and interviews with the goal of finding whether teachers' self-reports on textbook utilization differ from the actual situation in the classroom. The findings showed that the textbook played a central role in teachers' lesson preparation, as well as in the selection of worked examples and practice exercises for the students. Again, textbooks turned out to be very important as a source for homework.

The results concerning the extensive use of mathematics textbooks for lesson preparation (97 % use textbooks) raised a question about the role of the accompanying teacher guides in Croatia. The large-scale research (Glasnović Gracin & Domović, 2009) included a question about the use of teacher guides for planning instruction. The results show that participants relied heavily on teacher guides for lesson preparation, but not as much as on the textbooks. Around 23 % of surveyed teachers claimed they use teacher guides almost always and around 54 % do so often. These results suggest that the textbook is the basic tool for teachers' preparation. Still, altogether the percentage of 77 % of teachers who use the teacher guide encouraged us to investigate more in-depth the role of teacher guides in mathematics education and their influence on such extensive textbook use.

3. Theoretical framework

3.1. Model of teacher-curriculum interaction

To investigate, understand and explain the relationship between teachers and curriculum resources, Brown (2009) developed a theoretical framework called Design Capacity for Enactment Framework (DCE). The DCE model (Figure 1) represents the idea that the curriculum as well as the teacher's personal resources influences the designing and enacting of the instruction. Curriculum resources encompass physical objects, representations and procedures of the domain, while teachers'

personal resources denote subject matter knowledge, pedagogical content knowledge, beliefs and goals.

The DCE framework “provides a starting point for identifying and situating the factors that can influence how a teacher adapts, offloads, or improvises with curriculum resources” (Brown 2009, p. 27). Offloading denotes relying mostly on the curriculum resources for the delivery of the lesson; adapting indicates an equally-shared responsibility for the delivery of the lesson between teacher and curriculum resources; and improvising means that the teacher relies mostly on external and their own resources for delivering the lesson. Teachers either omit components of a lesson, or replace one component with another, or completely create new components during the adaptation process.

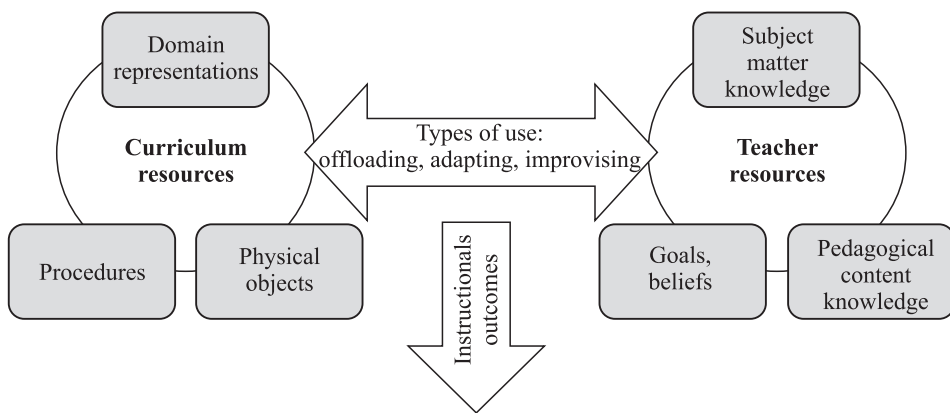

Figure 1. Brown's design capacity for enactment framework.

3.2. Voice of curriculum resources

The DCE framework is not an exhaustive model and can be broadened with the “voice” of the curriculum, contextual factors, cultural teaching norms, professional identity, or teachers’ orientation toward curriculum materials, etc.

Voice refers to how the authors or designers are represented and how they communicate with the teacher (Remillard, 2012). Curriculum resources communicate with the teacher using a certain voice: *talking through the teacher* and *talking to the teacher* (Remillard, *ibid*). When curriculum resources place primary emphasis on what the teacher should do, this characterizes talking through teachers (Remillard, 2000). This means that the authors communicate their intent through the actions they suggest the teacher takes. When the resource communicates about central ideas in the curriculum, this characterizes talking/speaking to the teacher.

The voice in the form of *talking to the teacher* is considered to be important aspect of educative curriculum resources (Davis & Krajcik, 2005; Hemmi et al. 2013; Remillard, 2012). Davis & Krajcik (2005) define educative curriculum resources as curriculum resources designed to support teacher learning as well as student

learning. They argue that an educative curriculum resource should offer transparent and direct guidance to the teacher, giving reasons and purposes underlying task selections (design rationale) or anticipating student responses. Remillard & Reinke (2012) challenged recently this assumption claiming that directive support in the form of talking through the teacher can be educative, when teachers are trying out new or unfamiliar practice. Directive support can offer new instructional moves or new pedagogical repertoire.

Davis & Krajcik (2005) focuses on opportunities for teacher learning within the practice of science teaching. Hemmi et al. (2013) created analytical tool for research in mathematics education (Table 1) based on guidelines from Davis and Krajcik (ibid).

Table 1. Analytical tool for examining educative features of curriculum resources.

Categories	Categories for data analysis
1a) General knowledge of students' ideas and strategies	Describes why students might hold particular ideas about mathematical concepts and exemplifies common strategies among students.
1b) Suggestions for how to encounter students' ideas and strategies	Gives suggestions for how to deal with/encounter various ideas and strategies of students and how to enhance their learning and prevent future difficulties.
2) Concepts and facts	Describes concepts and facts within mathematics such as history, field of application, derivations, methods, proofs, correct terminology.
3) Progression and mathematical connections	Shows the mathematics progression throughout the school years as well as connections between mathematical topics; for example, explains the future development of methods and concepts.
4) Connecting theory and practice	Supports the teacher's actions in practice beyond the curricular materials by connecting theory and practice. Exposes the central ideas in national curriculum and research results for promoting teachers' autonomy.
5) Design of teaching	Supports the teacher's ability to act in practice by suggestions with respect to the design and enactment of lessons, tasks, formative assessment, individualization of teaching, homework, etc.

Language use is also a part of voice. Herbel-Eisenmann (2007) found that the absence of first-person pronouns conceals the presence of human beings in the design of resources. Further, she noted that using second-person pronouns in conjunction with objects obscures the authority of the authors (e.g., *The table shows you. . .*).

3.3. Research questions

The previous large-scale research showed that the teachers extensively use textbooks for lesson preparation, and many of them use teacher guides (Glasnović Gracin & Domović, 2009; Glasnović Gracin, 2011). Therefore, we wanted to find a connection between teacher guide content and textbook use. In addition, the ways in

which the teacher mediates the curriculum materials are largely unknown (Pepin & Haggarty, 2001). The work reported in this paper aims to partly fill this gap and attempts to answer following research questions:

1. What is the difference between two editions of the teacher guides from the same publisher?
2. Does the change of the teacher guides influence the teacher practices and how?

The answers to these questions would help in clarifying the important role that the teacher guides as curriculum resources play in mathematics education.

4. Methodology

4.1. Design of the study

The study encompassed a longitudinal case study design with the aim to better understand how participants use the textbook in their teaching practice. According to Saldaña (2003), for a longitudinal case study it is important that the study meets the criteria of a span of at least one year for social studies and a span of at least nine months for educational projects. Case studies are very valuable research methods, used for investigating dynamic, experiential and complex processes and areas (Miles & Huberman, 1994) – in our case to give a real picture of the utilization of curriculum resources and to discover factors that influence teachers' decisions to use or not use the chosen textbook. To overcome possible deficiencies of the case study approach, we use a multimethod approach (e.g. Onwuegbuzie & Collins, 2007), namely we built our study on a previously conducted large scale study by Glasnović Gracin (2011).

The qualitative aspect of this study was conducted through classroom observations and interviews with teachers in two time spots, 2013 and 2017. We observed the same lesson themes in 2017, as we did in 2013.

4.2. Participants and teacher guides

The study involved two female mathematics teachers from lower secondary education in Croatia (grades five to eight). The participants were chosen according to several criteria: number of years of teaching, textbook choice and preference, and willingness to participate. In this study they are given the names Branka and Dunja. In 2017, Branka had 16 years of teaching experience and she liked the chosen official textbook used in her classroom. Dunja had 20 years of teaching experience, but she did not like the official textbook used in her classroom. The participants' affinities about textbook content and structure were identified as important for the study, because this is the aspect in which the two teachers differ. For several years

both participants had been mentors for pre-service teachers, and so we would not consider them to be inexperienced teachers.

Both teachers chosen for this study used the same textbook series in 2017 as they did in 2013. This mathematics textbook series is used by more than 65 % of pupils in lower secondary education in Croatia (data retrieved from the Ministry of Education, Science and Sport). This was the most used mathematics textbook in Croatian lower secondary education in these time periods. The publisher provides free copies of the accompanying teacher guides for teachers, so our participants had the teacher guides at their disposal for their lesson preparation.

In 2014, between the two case study time spots (2013 and 2017), new school textbooks were approved by Ministry of Education, Science and Sports for the next four-year school cycle. The new editions of the textbook series used by Branka and Dunja did not undergo significant changes, but the accompanying teacher guides did. The reason for changing the teacher guides but not the textbooks, is because in 2010, a new document called the National curriculum framework (MZOS, 2010) emerged, propagating new educational policy with emphasis on competences and student-centred teaching. However, this document was just a framework, and the old National plan and programme from 2006 (MZOS, 2006) remained the official document for what is to be taught in the classroom. This means that the textbooks were still following the document from 2006 (MZOS, 2006) and so did not undergo significant changes in 2014. However, the 2010 National curriculum framework (MZOS, 2010) recommendations on teaching methodology and instructional strategies were incorporated in the auxiliary curriculum resources, such as teacher guides, from 2014.

4.3. Data collection

Data gathering methods included document analysis, on-site observations of participants' teaching and semi-structured interviews (Cohen, Manion & Morrison, 2007). We observed Branka and Dunja in two time spots; in 2013 and in 2017. The observations were based on a structured plan, with the focus of identifying off-loading of content from the textbook, adapting the content, or improvising. Before each observation took place, the textbook and teacher guide content were analyzed in order to facilitate the initial coding during observation. To prevent conscious or non-conscious artificial behaviors and situations, we did not tell the teachers the exact focus of our observation.

In addition to classroom observations, we conducted semi-structured interviews with the teachers. The aim was to better understand the process of the teacher's preparation and why a particular curriculum resource was used. The interviews were semi-structured with a set of open-ended questions and outlines which were specified in advance (Table 2). This kind of interview approach enables flexibility and the rich collection of data (Cohen et al., 2007).

Table 2. Questions and outlines for semi-structured interview.

-
1. Describe how you usually prepare a mathematics lesson (in general and specifically for the observed lessons).
 2. Do you use the teacher guide in lesson preparation? If yes, how do you use it?
 3. How do you use the textbook in lesson planning, and how do you use it during lesson implementation (offloading, adapting improvising)? Elaborate for the observed lessons.
 4. Does the textbook, in your opinion, influence the structure of your instruction? (Title, definitions, language, symbols, sequence, didactical approach, worked examples, figures) Give reasons for your opinion.
-

After the classroom observations and interviews, we again analysed the same lesson units in the teacher guides and textbook in order to ascertain the role of the teacher guide in the classroom practice.

For the purposes of document analysis, the study included a qualitative content analysis (Mayring, 2000) of the two editions of teacher guide provided by the same publisher: the one used by teachers in 2013 and the other used in 2016. The aim was to better understand the interplay between the classroom practice and the two curriculum resources (teacher guide and textbook). We analysed the structure and content of the teacher guides to identify the similarities and differences between the two editions and their impact on what was happening in the classroom. This encompassed the different mobilizations of textbook use (offload, adopt, improvise) in them as well as the ‘voice’ of the teacher guides.

4.4. Data analysis

4.4.1. Analysis of the teacher guides

In order to answer the research questions, we analysed the Matematika 5, Matematika 6, Matematika 7 and Matematika 8 teacher guides used by both participants. In 2013, the teacher guides accompanying selected textbook were published in 2008, and in 2017, accompanying guides were published in 2014. Throughout the rest of the text, the teacher guides from 2008 will be referred to as the old teacher guides, and the ones from 2014 will be referred to as the new teacher guides. The analysis encompassed the structure and voice of the teacher guides, mobilizations of textbook use suggested in the teacher guides as well as the differences between the two editions. Here the first step was the analysis of the teacher guides for grades five and six. According to differences identified in the different editions of the guides we were able to see a pattern of changes emerging. We then analyzed the teacher guides for grades seven and eight to validate our assumptions. In order to support and validate our conclusions about the changes in the different editions, we thoroughly examined and compared the lesson plans for the specific observed lessons.

4.4.2. Analysis of observation reports and interview reports

The analysis of the classroom observation reports involved coding observed lesson parts regarding the interaction with curriculum resources: offloading, adapting or improvising. The next step was to find how much time in total each teacher spent on a particular type of interaction with the curriculum resources in both years. For example, Figure 2 presents part of this phase of data analysis, Branka's interaction with resources in the 2013 observation. Then we compared results with the corresponding lesson plan proposed in the teacher guide. This was done for classroom observations from 2013 and 2017.

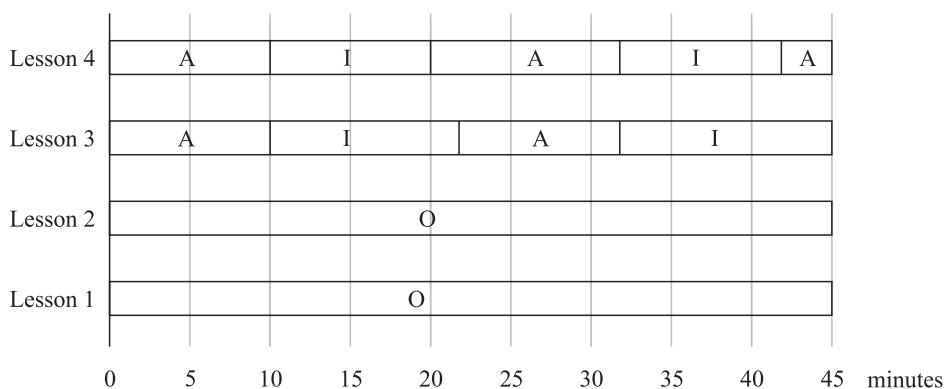

Figure 2. Branka's interaction with resources in observed lessons in 2013.

The next step involved the analysis of the transcribed interviews. Once the codes, themes and patterns were identified, we returned to the data to find further evidence and conflicting information. The coding captured how teachers described and understood their use of curriculum resources in lesson preparation, teaching new topics, practicing and reviewing.

5. Results

5.1. Two editions of teacher guides and their suggestions on textbook use

5.1.1. Structure and content of teacher guides

The old teacher guides are organized into the following chapters: general didactical outlines and principles; yearly and monthly plans; outlines of lesson plans for every unit, and a supplement with mathematical games and assessments. The new teacher guide has chapters ordered in the following way: general didactical outlines and principles; yearly and monthly plans; outlines of lesson plans. There are other sections included within the lesson plan outlines for each topic, these are: *lesson plans for every unit*; *mathematics assessment*; *additional activities for higher achieving students*, and *activities for struggling students*. Lesson plans for every

unit are supplemented with worksheets such as mathematical games, discovery learning activities, motivation for lessons, etc. The results of the content analysis show that both editions of the teacher guide have the same overall structure, but the sequence of content differs. There is a slight difference in the content of the joint structural parts and in the number of pages devoted to them (Table 3). But the greatest difference is the inclusion of the sections *additional activities for higher achieving students* and *activities for struggling students* within each mathematical topic in the new editions of the teacher guide. Structural parts will be elaborated on in the text below.

Table 3. Number of pages in teacher guides per structural parts.

Grade	Edition	Didact. part	Outlines of lesson plans*	Worksheets with games	Assess.	Worksheets (advanced students)	Worksheets (struggling students)
5	old	16	162	97	50	0	0
	new	54	199	81	43	27	57
6	old	16	156	24	46	0	0
	new	54	248	54	66	19	102
7	old	16	154	42	60	0	0
	new	54	248	46	99	14	77
8	old	16	152	35	35	0	0
	new	54	210	35	64	24	82

*Didactical part is the general didactical part; outlines of lesson plans are suggestions of lesson plans without worksheets; assess, means assessments.

The general didactical part of the old teacher guide for each grade (five to eight) encompasses general didactical topics and teaching methods. This part contains the goals and aims of mathematics education, a description of general methods of organizing work and forms of work and teaching tools. It also contains sections highlighting the importance of correlation with other school subjects, topics on assessing students' achievement, and working with children who have learning difficulties such as dyslexia. All these sections are also in the new editions, but they have been extended. For instance, goals are described through intended learning outcomes using Bloom's taxonomy. Instead of only referring to the curriculum outlines from 2006 (MZOS, 2006), the new teacher guides also cite the National Curriculum Framework (MZOS, 2010). In the section that deals with assessment, several types of assessment are described and discussed, for instance, the constraints and affordances of formative and summative assessment. There is also a self-evaluation sheet for teachers subsequent to enacting a lesson. The section on children with special needs contains more detail on, for example, how to construct individualized programs, and how to organize additional classes for struggling and advanced students.

The main part of both the old and new teacher guides consists of lesson plans. The number of lesson plans provided corresponds to the number of mathematics

lessons in a school year. Each lesson plan encompasses intended learning outcomes, the main goal and recommended activities for a particular lesson. The recommended activities are divided into three parts: introductory activities, the main part of the lesson, and the final activities. The analysis shows that the lesson plans follow the structure of the textbook, suggesting what textbook examples and tasks to use. There is a difference in the lesson plans in the old and new guides which will be elaborated on in the following section.

The old guides contain a section with mathematical games, like Sudoku, puzzles, etc., placed separately from the lessons plans in a supplement, while in the new guides the games are placed alongside the lesson plans as attachments to a particular lesson unit. Both editions contain sections for mathematics assessment. In the old edition they are placed in the supplement part with the games. In the new edition, they are placed within the topic they are assessing.

As mentioned earlier, the new teacher guides contain new sections: *additional activities for better achieving students* and *activities for struggling students*. They contain suggestions for exercises for those students who need more challenging tasks and those who need simpler tasks. However, the lesson plans do not contain explicit differentiation according to ability or references to these sections.

5.1.2. Suggestions for adapting, offloading and improvising in the teacher guides

The old teacher guides promote significant offloading on the textbook and fragments of improvising. This offloading means that the lesson plan specifically refers to the worked examples, exercises, figures or other content in the textbook. Improvisations in this case are those guidelines which suggest what should be done, but not how it should be done and do not directly refer to the textbook. The old teacher guides occasionally suggest offloading materials for short assessments or a worksheet.

The new teacher guides suggest offloading textbook content, but also, in almost equal measure, they suggest offloading the material provided in the teacher guide. For instance, for the sixth-grade topic *Operations with fractions*, consisting of 22 lesson plans, the old guide offloads the material from the teacher guide in 8 lesson plans. For the same topic, the new edition offloads from the teacher guide in 19 lesson plans. Further, the new edition has fragments of improvisations in the same manner as the old edition.

However, at the beginning of the lesson plan section in both editions of the teacher guides, the authors state that the provided lesson plans are just one possible way of approaching the lesson, which indicates that the teacher can adapt lesson plans and materials according to their goals.

The voice of the teacher guide

In this section, we report on the voice of the analyzed teacher guides. We provide a table with results of the analysis using following marks: sentences or phrases that occurred regularly in connection to most mathematical areas (++) , sporadically with only some sentences (+), or were totally missing (–) (Table 4).

Table 4. Analysis of educative features in teacher guides.

	Old guides	New guides
1a) General knowledge of students' ideas and strategies	–	+
1b) Suggestions for how to encounter students' ideas and strategies	–	–
2) Concepts and facts	–	–
3) Progression and mathematical connections	+	+
4) Connecting theory and practice	–	–
5) Design of teaching	++	++

The old teacher guides do not provide a discussion of the strengths and weaknesses of the presented approaches to teaching a certain topic (Category 1). At the beginning of the guides there is yearly lesson plan displaying how the textbook and the goals for the students are connected to the goals in the curricula (Category 3). In the daily lesson plans, the guides lists what is to be reviewed for upcoming lessons but now why it is necessary or how it will connect to the new topics. For instance, in the lesson on the introduction of rational numbers, there is a list of tasks: to review the concept of a fraction, to review the basics of integers, to introduce negative fractions as a result of a division of two integers with different signs (Category 3). Topics dealing with mathematical knowledge (Category 2) do not occur nor connecting research and practice (Category 4).

The lesson plans in the old teacher guides follow the textbook structure closely, rarely offering activities outside the textbook (Category 5). They only occasionally refer to the activities at the back, in the section with the mathematical games. In general, the lesson plans do not refer to the corresponding games at the end of the book, so it seems that it is up to the teacher to connect a game with an appropriate lesson. The instructions to the teacher are prescribed and follow the sequence of the worked examples and tasks in the assigned textbook. These teacher guides are oriented towards teachers, directing teacher actions in the classroom and what the teachers should do or say.

In the old edition, the authors address the teacher in an impersonal form using verbs in the infinitive: to introduce, to describe, to define, etc. It seems that the resource does not directly refer to the teacher, and does not use personal pronouns. According to Remillard (2000), it can be concluded that the old teacher guides are *talking through the teacher*.

In the new teacher guides, the lesson plans are more oriented towards the students: they show what the students should do, but also directing the teacher's

action (Category 5). They follow the textbook content, but offer and suggest many activities that are not in the textbook and that can be given as ready-made worksheets. The new lesson plans have more activities incorporated in one lesson (plan) unit, from and outside the textbook (Category 5). In many cases, the intent of the suggested activity is described to the teacher in the aim of the activity, so it can be said that the design of the activity is transparent. Some lesson plans provide alternative activities, which means that the teacher can choose between two activities (Category 5).

The main body of the lesson plan contains direct guidance for enacting the lesson, but does not suggest what the teacher should ask students when dealing with the activities, nor does it provide examples of students' possible misconceptions (Category 1b). There are no explanations of the strengths or weaknesses of the suggested approaches to teaching the new topics. However, the guides provides answers students should give for the suggested activities (Category 1a). Those answers are product oriented, not process oriented guide. At the beginning of the guides there is yearly plan displaying how the textbook and the goals for the students are connected to the goals in the curricula (Category 3). In the daily lesson plans, the guides list what is to be reviewed for upcoming lessons but now why it is necessary or how it will connect to the new topics. Sporadically guides connect concepts with future utilization of those concepts. Topics dealing with mathematical knowledge (Category 2) do not occur nor connecting research and practice (Category 4).

The new teacher guides do not use personal pronouns when describing actions either. All things considered, the new guides are still *talking through the teacher*.

5.2. Teachers' view of teacher guides

In 2013, Dunja explained that she consults the teacher guide when she prepares lessons, indicating that the teacher guide is also a resource in her lesson preparation. She expressed her dissatisfaction with lesson plans in the teacher guide, claiming that they are created for an unrealistic environment.

“These are ready-made lesson plans [...] and as I say they are beautifully written. It is not possible in the classroom to do what they suggest. If you have 15 students, who are silent and staring at you, then you can do what they suggest.” [Year 2013]

She pointed out that she uses “interesting activities” from the teacher guide. Her stance toward the lesson plans from the teacher guide was similar in 2017. However, Dunja explained she noticed the difference between the old and new versions, pointing out that in the new edition there are “many good materials to work with, especially many guided discovery learning worksheets”. But she still needs to adapt them to the students' needs. She also mentioned that she changes the proposed sequence of activities:

“They [the authors] always provide too many [activities]. You don’t have time for all that in one lesson. Sometimes I don’t agree with the sequence of the proposed activities, they don’t make sense in that order.” [Year 2017]

In 2013, Branka explained she relies also on the teacher guide, when she prepares lessons, but she added that she cannot use the ready-made lesson plans without reflecting on them:

“When I prepare, I check various resources like the teacher guide [...] But I can’t use the ready-made lesson plans if they not suit me” [Year 2013]

Her stance toward the ready-made lesson plans had not changed in 2017, claiming that she cannot follow them blindly; she has to reflect on the sequence and outcomes of the activities. Here she pointed out that sometimes she uses lesson plan as given and other times she uses some activities from the guide. Everything she does is guided with the students’ best interest, so she adapts according to her students’ needs if necessary. Referring to the difference between the old and new editions, she remarked on the change in lesson plans:

“Superficially it seems the same, but when you dig deeper, there are a lot of new activities in the lesson plans [...] And you can see that some smart people made it.” [Year 2017]

5.3. Teachers’ mobilization of resources

Even though Branka and Dunja represent teachers with opposite affinities toward the textbook they are using in the classroom, they both offloaded on the textbook, adapted and improvised in the lessons, but not to the same extent in every lesson.

Table 5. Dunja’s mobilization of textbook and teacher guide (percentage for a lesson of 45 minutes).

Year		Offloading	Adapting	Improvising
2013	Lesson 1	45 %	0 %	55 %
	Lesson 2	0 %	0 %	100 %
	Lesson 3	0 %	100 %	0 %
2017	Lesson 1	20 %	10 %	55 %
	Lesson 2	0 %	0 %	100 %
	Lesson 3	5 %	0 %	95 %

In the Table 5, we present the data for the lesson we observed in Dunja’s classroom. We observed the same lesson themes in 2017, as we observed in 2013. It seems that Dunja reduced the amount of offloaded content in 2017 in comparison to 2013, and increased the amount of improvising in 2017. No lesson in 2017 matched the lessons we saw in 2013 in respect to the motivation, amount of mathematical content incorporated in the lesson or assigned homework. The similar characteristics of lesson were detected in Lesson 1 where teacher used the same

textbook exercises in 2013 and 2017. In 2013, Dunja adapted the content from the textbook in Lesson 3, giving exercises with similar pedagogy as in the textbook, and in 2017, Dunja created the activities herself.

The results of the observed lessons match the results obtained in the interviews in 2013 and 2017. Both times Dunja revealed she frequently uses her personal resources for motivation, introductory activities and teaching new content, but she uses the textbook for exercises if the tasks meet her goals. In 2017, she explained that she reads a lot, so she finds many interesting tasks, which inspire her to create her own activities.

“Some worked examples from the textbook I do use, but motivation no. That is my contribution. The introduction of a new concept or procedure is also my work.” [Year 2013]

“I use the textbook for exercises. If the tasks there meet my goals for the introduction of new content no... that part is poorly designed in the textbook.” [Year 2017]

Table 6. Branka’s mobilization of textbook and teacher guide (percentage for a lesson of 45 minutes).

Year		Offloading	Adapting	Improvising
2013	Lesson 1	100 %	0 %	0 %
	Lesson 2	100 %	0 %	0 %
	Lesson 3	0 %	50 %	50 %
	Lesson 4	50 %	0 %	50 %
2017	Lesson 1	50 %	0 %	50 %
	Lesson 2	50 %	0 %	50 %
	Lesson 3	0 %	50 %	50 %
	Lesson 4	0 %	55 %	45 %

In the Table 6, we present the data for the lesson we observed in Branka’s classroom. We observed the same lesson themes in 2017, as we observed in 2013. In Branka’s case, a greater change in her mobilization of the textbook between 2013 and 2017 can be detected in terms of offloading and improvising. In 2013 she offloaded two lessons (Lesson 1 and Lesson 2) on the textbook. The structure of the lessons, chosen activities and homework corresponded to the lesson plans in the teacher guide. In 2017, Branka also improvised in those lessons using her personal resources: she created guided discovery worksheets which followed Geogebra applet. In the interview, she explained that new teacher guides offer various guide discovery activities so she created similar for the observed topics. Lessons observed in 2013 and 2017 differed in terms of chosen methods and chosen exercises. For instance, Lessons 3 and Lesson 4 had the same structure and amount of mathematical content in 2013 and 2017, but the chosen exercises differed. The teacher adapted both times exercises from the textbook, and each time the adaptation was different. In 2013 Lesson 1 and Lesson 2 were organized as teaching

angles with parallel and perpendicular arms using heuristic conversation, and then exercising the aforementioned topic. But in 2017, students investigated the angles with parallel arms in Lesson 1 using pair work and in Lesson 2, they investigated the angles with perpendicular arms.

In the interviews, Branka stated that she follows the textbook to certain extent, using worked examples from the textbook, exercises, title and definitions. Sometimes she teaches new content as it is presented in the textbook, and sometimes she does it differently, depending on whether the pedagogy behind it is appropriate.

In two lessons in 2013 and 2017 (Lesson 3 and Lesson 4), Branka made worksheets with exercises resembling exercises in the textbook; one for practicing rationalization of denominator, the other was preparation for the upcoming exam in the topic *Squaring and taking square root*. Branka explained that she sometimes makes worksheets resembling exercises from the textbook so students have more material for practicing at home:

“I made these worksheets for the average students. I did not want to use tasks from the textbook [...] to leave them something for practicing at home. Then they know the level I want them to learn.” [Year, 2013]

In both interviews, she indicated the national curriculum outlines (MZOS, 2006) as the starting point for her lesson which leads her to adjusting, adapting or adopting selected activities.

“Given the learning outcomes that we have to achieve, I direct and adapt activities and exercises toward them, and that’s why I can’t use someone else’s lesson plan.” [Year, 2013]

In the case of using written exams or short written assessments from the teacher guides, both teachers expressed negative opinions in 2013. Dunja explained:

“I always write my own exams. . . Each year I put something new in, or I throw something out. Different generations [of students] don’t learn everything in the same way. So I focus on what they found more difficult to master.” [Year 2013]

Branka’s response was similar, but she also explained that she writes differentiated exams according to students’ abilities, and she organizes revision for the exam accordingly. They were both of the same opinion in 2017.

6. Discussion and conclusions

6.1. The teacher guide

The analysis of the teacher guides shows that both editions have the same structure, but the new edition is much extended with additional activities and modern approaches such as discovery learning. While in most lessons the old teacher guide encourages following the textbook content, the new guide, in addition to textbook use, suggests numerous other activities. These activities are given in the teacher

guide and are intended to be used directly from the guide in classroom practice, without the textbook as mediator.

In terms of the “voice”, the analysis of old teacher guides showed that guides are talking through the teacher, directing teacher’s actions in the classroom. The new guides possess more educative features, but still talk through the teachers. Both guides place emphasis on the teacher’s actions, what the teacher should do and how to employ students in the classroom, rather than communicating with teachers about the central mathematical ideas in focus. These findings are not entirely in line with the national requirements that a teacher guide “does not prescribe the procedures or limit the teacher’s creativity while planning the teaching process” (Official Gazette of the Republic of Croatia 59, 2003, Article 1).

More educative features must be included in the teacher guides for their greater change. The authors of such materials should include, for instance, anticipated students thinking – what students are likely to think and what they find confusing. One could argue that experienced teachers can foresee students’ misconceptions, but what about novice and inexperienced teachers? Also, do we expect that teachers always have or remember such knowledge for every mathematical topic?

6.2. Mobilization of resources

This longitudinal study showed that teachers’ classroom practice is quite stable; it did not change significantly with the new teacher guides. The only change noticed is in Branka’s classroom. In 2013 she adapted and offloaded from the textbook, but barely improvised. The new edition of the teacher guide with a variety of activities inspired her to decrease offloading and increase improvising (Table 6). Dunja’s mobilization did not vary significantly across the observational cycles. This finding is in line with a result of the large-scale questionnaire about the use of mathematics textbooks (Glasnović Gracin, 2011): the teachers involved stated that they do not change their teaching practice when they change the textbook. It seems that teachers position themselves as having authority over the textbook and accompanying teacher guide in the classroom.

As experienced teachers, Dunja and Branka mobilized the official resources depending on the goal they wanted to achieve and considering students’ best interest. Their interaction with the resources can be described as a dynamic interplay between personal beliefs and the characteristics of the resources, showing that the process of teaching is indeed a design process (Brown, 2009). The lessons in 2017 can be seen as improved version of the lessons in 2013. The fact that same lessons themes differed in 2013 and 2017 shows that teachers designed lessons in 2017 with respect to what they have learned from prior enactments. This outcome can be denoted as learned adaptations (Choppin, 2011), which involve an understanding of how curriculum resources can be used to design instruction with respect to particular instructional outcomes. According to Choppin (*ibid*), teachers’ understanding of used resources does not develop only from reading the resource materials, but also from applying systematic inquiry in their own classrooms. Teachers in our study learned from their enacted lesson, taking into account positive and negative

outcomes, and as a consequence, they improved their ability of lesson designing. This is also supported with the attitude toward the teacher guide. Even though Branka leaned more on the old teacher guide, the new teacher guide became a resource of additional activities. Dunja retained the same attitude toward new as she had for the old teacher guide.

Through the years, between 2013 and 2017, with various influences of formal and informal professional learning, the teachers in the study enlarged their knowledge base-their personal resources. However, the question remains if more educative teacher guide would promote greater change in the teachers' utilization of curriculum resources. And this opens the door for further research.

References

- [1] ADLER, J. (2012). Knowledge resources in and for school mathematics teaching. in G. Gueudet, B. Pepin, & L. Trouche (Eds.), *From text to 'lived' resources: Mathematics curriculum materials and teacher development*, (pp. 3–22), Dordrecht: Springer.
- [2] AHL, L., GUNNARSDÓTTIR, G. H., KOLJONEN, T. & PÁLSDÓTTIR, G. (2015). How teachers interact and use teacher guides in mathematics – cases from Sweden and Iceland. *Nordic Studies in Mathematics Education*, 20 (3–4), 179–197.
- [3] AHL, L., KOLJONEN, T. & HOELGAARD, L. (2014). How are mathematics teacher guides used for support and inspiration in teaching? in H. Silfverberg, T. Kärki & M. Hannula (eds.), *Proceedings of Nordic research in mathematics education*, (pp. 153–162), Turku: University of Turku, Department of Teacher Education.
- [4] BALL, D. L., & COHEN, D. K. (1996). Reform by the book: What is: or might be: the role of curriculum materials in teacher learning and instructional reform? *Educational Researcher*, 25(9), 6–14.
- [5] BROWN, M. (2009). *The Teacher-Tool Relationship: Theorizing the Design and Use of Curriculum Materials*. in J. T. Remillard, B. A. Herbel-Eisenmann & G. M. Lloyd (Eds.), *Mathematics teachers at work: connecting curriculum materials and classroom instruction*, (pp. 17–36), New York: Routledge.
- [6] CHOPPIN, J. (2011). Learned adaptations: Teachers' understanding and use of curriculum resources. *Journal of Mathematics Teacher Education*, 14(5), 331–353.
- [7] COHEN, L., MANION, L., MORRISON, K. (2007). *Research methods in education*. Abingdon: Routledge.
- [8] DAVIS, E. A., & KRAJCIK, J. S. (2005). Designing educative curriculum materials to promote teacher learning. *Educational Researcher*, 34(3), 3–14.
- [9] FAN, L. (2013). Textbook research as scientific research: towards a common ground on issues and methods of research on mathematics textbooks. *ZDM – Mathematics Education*, 45(5), 765–777.
- [10] FAN, L., ZHU, Y. & MIAO, Z. (2013). Textbook research in mathematics education: development status and directions. *ZDM – Mathematics Education*, 45(5), 633–646.
- [11] GLASNOVIĆ GRACIN, D. & DOMOVIĆ, V. (2009). Upotreba matematičkih udžbenika u nastavi viših razreda osnovne škole. *Odgojne znanosti*, 11, 297–317, in Croatian.

- [12] GLASNOVIĆ GRACIN, D. (2011). *Requirements in mathematics textbooks and PISA assessment* (Doctoral dissertation). Klagenfurt: University of Klagenfurt.
- [13] GLASNOVIĆ GRACIN, D., & JUKIĆ MATIĆ, LJ. (2016). The role of mathematics textbooks in lower secondary education in Croatia: An empirical study. *The Mathematics Educator*, 16(2), 29–56.
- [14] GREVHOLM, B. (2014). Frågor om läroboken i matematik – vilka är de och finns det några svar? [Questions about the mathematics textbook – what are they and are there any answers?]. in K. Wallby, U. Dahlberg, O. Helenius, J. Häggström & A. Wallby (Eds.), *Nämna Tema 10 Matematikundervisning i praktiken* (pp. 147–160), Gothenburg: National Centre for Mathematics Education.
- [15] GUNNARSDÓTTIR, G. H. & PÁLSDÓTTIR, G. (2014). How do teachers use teacher guides in mathematics? in H. Silfverberg, T. Kärki & M. S. Hannula (Eds.), *Proceedings of Nordic research in mathematics education*, (pp. 195–204) Turku, Finland: The Finnish Research Association for Subject Didactics.
- [16] HEMMI, K., KOLJONEN, T., HOELGAARD, L., AHL, L., & RYVE, A. (2013). Analyzing mathematics curriculum materials in Sweden and in Finland: Developing an analytical tool. in B. Ubuz, C. Haser, & M. A. Mariotti, (Eds.), *Proceedings of the Eighth Congress of the European Society for Research in Mathematics Education*, Ankara, Turkey: Middle East Technical University and ERME.
- [17] HERBEL-EISENMANN, B. A. (2007). From the intended curriculum to the written curriculum: Finding the “voice” of a mathematics textbook. *Journal for Research in Mathematics Education*, 38(4), 344–369.
- [18] HEYMANN, H. W. (1996). *Allgemeinbildung und Mathematik*. Weinheim: Beltz Verlag.
- [19] HOELGAARD, L., HEMMI, K. & RYVE, A. (2014). Teaching by the book: What kind of classroom practice do three different teacher guides for year 1 promote? in H. Silfverberg, T. Kärki & M. Hannula (eds.), *Proceedings of Nordic research in mathematics education*, (pp. 163–172), Turku: University of Turku, Department of Teacher Education.
- [20] JOHANSSON, M. (2006). *Teaching mathematics with textbooks. A classroom and curricular perspective* (Doctoral dissertation). Luleå: Luleå University of Technology.
- [21] MAYRING, P. (2000). Qualitative content analysis. *Forum: Qualitative Social Research*, 1(2), retrieved from <http://www.qualitative-research.net/index.php/fqs/article/view/1089/2385>.
- [22] MILES, M. B., & HUBERMAN, A. M. (1994). *Qualitative data analysis: An expanded sourcebook*. London: Sage.
- [23] MZOS [Ministarstvo znanosti, obrazovanja i športa Republike Hrvatske] (2006). *Nastavni plan i program*. Zagreb, in Croatian.
- [24] MZOS [Ministarstvo znanosti, obrazovanja i športa Republike Hrvatske] (2010). *Nacionalni okvirni kurikulum*. Zagreb, in Croatian.
- [25] NICOL, C. C., & CRESPO, S. M. (2006). Learning to teach with mathematics textbooks: How pre-service teachers interpret and use curriculum materials. *Educational Studies in Mathematics*, 62(3), 331–355.

- [26] ONWUEGBUZIE, A. J., & COLLINS, K. M. T. (2007). A typology of mixed methods sampling designs in social science research. *The Qualitative Report*, 12(2), 281–316, retrieved September 30, 2016, from <http://www.nova.edu/ssss/QR/QR12-2/onwuegbuzie2.pdf>.
- [27] PEPIN, B. & HAGGARTY, L. (2001). Mathematics textbooks and their use in English, French and German classrooms: a way to understand teaching and learning cultures. *ZDM – Mathematics Education*, 33(5), 158–175.
- [28] PEPIN, B., GUEUDET, G., & TROUCHE, L. (2013). Re-sourcing teachers' work and interactions: a collective perspective on resources, their use and transformation. *ZDM – Mathematics Education*, 45(7), 929–943.
- [29] REMILLARD, J. T. (2000). Can curriculum materials support teachers' learning? Two fourth-grade teachers' use of a new mathematics text. *The Elementary School Journal*, 100(4), 331–350.
- [30] REMILLARD, J. T. (2005). Examining key concepts in research on teachers' use of mathematics curricula. *Educational Research*, 75(2), 211–246.
- [31] REMILLARD, J. T., & BRYANS, M. B. (2004). Teachers' orientations toward mathematics curriculum materials: Implications for teacher learning. *Journal for Research in Mathematics Education*, 35(5), 352–388.
- [32] REMILLARD, J. T., & REINKE, L. (2012). *Complicating scripted curriculum: Can scripts be educative for teachers?* Paper presented at the AERA annual meeting, Vancouver, Canada.
- [33] REMILLARD, J. T., VAN STEENBRUGGE, H., & BERQUIST, T. (2014). A cross-cultural analysis of the voice of curriculum materials. in K. Jones, C. Bokhove, G. Howson & L. Fan (Eds.), *Proceedings of the International Conference on Mathematics Textbook Research and Development*, (pp. 395–400), Southampton: University of Southampton.
- [34] REMILLARD, J. T. (2012). Modes of engagement: Understanding teachers' transactions with mathematics curriculum resources. in G. Gueudet, B. Pepin, & L. Trouche (Eds.), *From text to 'lived' resources: Mathematics curriculum materials and teacher development*, (pp. 105–122), Netherlands: Springer.
- [35] REZAT, S. (2014). Teacher guides as instruments for teaching mathematics: a case study. in K. Jones, C. Bokhove, G. Howson and L. Fan, Lianghuo, *Proceedings of the International Conference on Mathematics Textbook Research and Development*, (pp. 401–406) Southampton, UK: University of Southampton.
- [36] SALDAÑA, J. (2003). *Longitudinal qualitative research*. California: AltaMira Press.
- [37] VALVERDE, G. A., BIANCHI, L. J., WOLFE, R. G., SCHMIDT, W. H., & HOUANG, R. T. (2002). *According to the Book: Using TIMSS to investigate the translation of policy into practice through the world of textbooks*. Dordrecht: Kluwer.
- [38] VAN STEENBRUGGE, H., & BERGQVIST, T. (2014). *Mathematics curriculum programs as tools for design: an analysis of the forms of address*. Paper presented at the AERA annual meeting, Philadelphia.
- [39] ZHU, Y. & FAN, L. (2002). Textbook use by Singaporean mathematics teachers at lower secondary school level. in D. Edge & Y. B. Har (Eds.), *Mathematics education for a knowledge-based era*, (Vol. 2., pp. 194–201), Singapore: AME.

- [40] Narodne novine (The Official Gazette of the Republic of Croatia) (2001). *Zakon o udžbenicima za osnovnu i srednju školu*. in: *Narodne novine* (The Official Gazette of the Republic of Croatia), 117 (Dec 24th, 2001).
- [41] Narodne novine (The Official Gazette of the Republic of Croatia) (2003). *Zakon o osnovnom školstvu*. in: *Narodne novine* (The Official Gazette of the Republic of Croatia), 69 (Apr 23rd, 2010).
- [42] Narodne novine (The Official Gazette of the Republic of Croatia) (2010). *Zakon o udžbenicima za osnovnu i srednju školu*. in: *Narodne novine* (The Official Gazette of the Republic of Croatia), 27 (Mar 2nd, 2010).

Teacher guides

- [1] GOLEŠ, B., & LOBOR, Z. (2008). *Matematika 5, Priručnik za učiteljice/učitelje za peti razred osnovne škole*. Zagreb: Profil.
- [2] DRAŽENović-ŽITKO, V. & MARIĆ, M. (2008). *Matematika 6, Priručnik za učiteljice/učitelje za šesti razred osnovne škole*. Zagreb: Profil.
- [3] GOLAC-JAKOPOVIĆ, I., & VUKOVIĆ, M. (2008). *Matematika 7, Priručnik za učiteljice/učitelje za sedmi razred osnovne škole*. Zagreb: Profil.
- [4] NEMETH, T., & STAJČIĆ, G. (2008). *Matematika 8, Priručnik za učiteljice/učitelje za osmi razred osnovne škole*. Zagreb: Profil.
- [5] GOLEŠ, B., & LOBOR, Z. (2014). *Matematika 5, Priručnik za učiteljice/učitelje za peti razred osnovne škole*. Zagreb: Profil.
- [6] DRAŽENović-ŽITKO, V. & MARIĆ, M. (2014). *Matematika 6, Priručnik za učiteljice/učitelje za šesti razred osnovne škole*. Zagreb: Profil.
- [7] GOLAC-JAKOPOVIĆ, I., & VUKOVIĆ, M. (2014). *Matematika 7, Priručnik za učiteljice/učitelje za sedmi razred osnovne škole*. Zagreb: Profil.
- [8] NEMETH, T., & STAJČIĆ, G. (2014). *Matematika 8, Priručnik za učiteljice/učitelje za osmi razred osnovne škole*. Zagreb: Profil.

Contact addresses:

Ljerka Jukić Matić
Department of Mathematics
University of Osijek
Trg Ljudevita Gaja 6, 31000 Osijek, Croatia
e-mail: ljukic@mathos.hr

Dubravka Glasnović Gracin
Faculty of Teacher Education
University of Zagreb
Savska 33, 10000 Zagreb, Croatia
e-mail: dubravka.glasnovic@ufzg.hr

Utjecaj priručnika za učitelje matematike na nastavu matematike

Ljerka Jukić Matić¹ i Dubravka Glasnović Gracin²

¹Odjel za matematiku, Sveučilište u Osijeku, Osijek, Hrvatska

²Učiteljski fakultet, Sveučilište u Zagrebu, Zagreb, Hrvatska

Sažetak. Udžbenici i pripadni priručnici za učitelje prepoznati su kao važni i utjecajni resursi u nastavi matematike. Učitelji se u velikoj mjeri oslanjaju na udžbenik prilikom planiranja, ali i samog izvođenja nastave: osmišljavaju nastavu prema strukturi udžbenika, podučavaju nove sadržaje prema udžbeniku i koriste udžbenik kao izvor za vježbanje i zadavanje domaće zadaće. Ova studija istražuje kakvu ulogu ima priručnik za nastavu matematike u nastavnoj praksi učitelja i kako priručnik utječe na samo korištenje udžbenika. Studija također istražuje kakav odnos imaju učitelji s udžbenikom ako se priručnik promijenio u svom sadržaju i strukturi. Iako su rezultati studije pokazali relativnu stabilnost nastavne prakse, otkrili smo da postoji edukativni utjecaj priručnika na učitelje; naime priručnik je potaknuo korištenje aktivnih nastavnih metoda u učionici.

Ključne riječi: nastavna praksa, longitudinalna studija, učitelj, udžbenik, priručnik za nastavu matematike

Redesigning a contextual textbook task with an exponential-type function using *a posteriori* analysis of the prospective mathematics teachers' work

Željka Milin Šipuš¹, Aleksandra Čižmešija¹ and Ana Katalenić²

¹Faculty of Science, University of Zagreb, Croatia

²Faculty of Education, University of Osijek, Croatia

Abstract. An exponential function is one of the elementary functions in mathematical modelling and a common part of the upper secondary mathematics curriculum. A horizontal asymptote is a prominent feature of an exponential function graph. We have performed a comprehensive study within the Anthropological Theory of the Didactics (ATD) on asymptotes and asymptotic behaviour in the context of upper secondary mathematics education in Croatia. Therein, we administered three questionnaires with prospective mathematics teachers. One of the tasks from the questionnaires was *a priori* designed to explore the role of an asymptote in graphing and describing an exponential function. In this paper, we present results of an *a posteriori* analysis of students' work on the modified contextual textbook task with an exponential-type function. We discuss the affordances of the textbook versus redesigned task and provide suggestions for task selection and design to promote coherency and discourse in students' available mathematical knowledge.

Keywords: Anthropological Theory of the Didactics, *a posteriori* analysis, contextual task, exponential function, function graph, task design

1. Introduction

Contextual tasks are common items in mathematics textbooks. They are used to motivate, exercise or produce new knowledge and skills at all levels of mathematics education. An exponential function is used to model different contexts, such as population growth or radioactive decay, but the bounded growth is rarely present in the textbook for upper secondary mathematics education in Croatia. As a part of a broader study, we engaged university students, who are prospective mathematics teachers, to solve a modified textbook task that was a contextual task with bounded exponential growth.

Our broader study was aimed to investigate the asymptotes and asymptotic behaviour as a body of knowledge in upper secondary mathematics education in Croatia. It followed the framework of the Anthropological Theory of the Didactics (ATD). An *a posteriori* analysis of students' work in the task mentioned above showed opportunities for task (re)design to create a theoretically based, paradigmatically different activity with a contextual task.

In the following section, we present references for results and notions used in the analysis. We draw on the literature review to pose our research questions. In the third section, devoted to context and methodology, we outline the setting of the broader study and present the data relevant for this analysis. The same section includes a thorough *a priori* analysis of the textbook task and a modified task. In the fourth section, we present the results of the analysis complemented with students' work in figures. The last two sections include discussion and guidelines for further task design along with observations relevant for mathematics education.

2. Literature review

Mathematical tasks have a significant role in teaching and learning mathematics. Mathematics teachers worldwide and in Croatia confide in textbooks as the main source of the mathematical tasks and activities that they use in the classroom (Glasnović Gracin & Jukić Matić, 2016; Jukić Matić & Glasnović Gracin, 2016). In this paper, we investigate and discuss the issues and potentials of a contextual textbook task. Roth (1996) distinguished three issues of context that a mathematical task could bear: (1) all the given or implied information needed to solve or understand a task; (2) a real-world phenomenon that is modelled with some mathematical body of knowledge; (3) any setting that provides a situation to practise some mathematical body of knowledge. The latter presumes an actual, effective use of mathematics in everyday and professional life. Textbook tasks, commonly called "word" or "textual" problems, are mainly contextual in the sense that some additional meaning drawn from the real world is given to a formal, mathematical body of knowledge. In mathematics education, such tasks are used to motivate students for learning (doing) mathematics and to engage their problem-solving skills and creativity (Gravemeijer & Doorman, 1999; Verschaffel, Depaepe, & Dooren, 2014).

An exponential function is an elementary function and it is a common part of mathematics curricula in upper secondary education. Introduction and development of this body of knowledge are founded on the algebra of powers, approximate or digital calculations and graphing (Čižmešija, Katalenić, & Milin Šipuš, 2017; Confrey, 1991; Winsløw, 2013). The studies revealed that students are expected mainly to manipulate and evaluate algebraic expressions and that there is a lack of technologically available discourse about the extension from integers to real number exponents (Čižmešija *et al.*, 2017; Confrey, 1991; Winsløw, 2013).

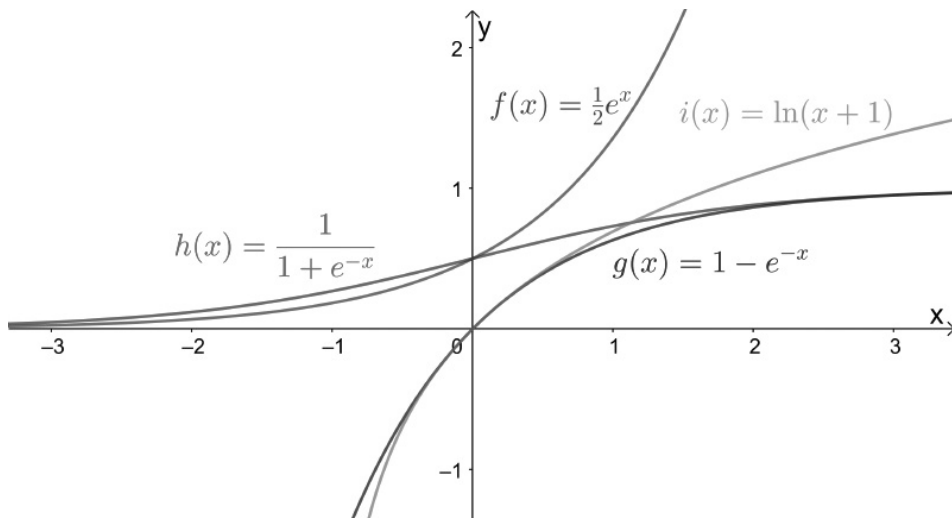

Figure 1. Graphical representations of different exponential models (exponential growth – function f ; bounded exponential growth – function g ; logistic function – function h ; logarithmic growth – function i).

A general exponential function has an unbounded growth that is faster than the growth of any power function. Exponential growth or decay is often used in mathematical modelling. Other important exponential models are bounded exponential growth and logistic function that are used to model population growth with some fixed capacity. These models are increasing functions bounded from above by their horizontal asymptote. Even though the graphs of a bounded exponential growth and logistic function are similar to the graph of a logarithmic function on the first sight, they are fundamentally different since a logarithmic function is increasing (though slow) unboundedly (Figure 1).

Mathematical experts easily recognize and classify many elementary or composite functions as those mentioned above, whereas for students it is difficult to recognize, interpret and manipulate all aspects of elementary functions and other mathematical objects (Duval, 1993; Kop, Janssen, Drijvers, & van Driel, 2017; Vandebrouck, 2011). Duval (1993) extensively elaborated how students should engage with different registers of representations when doing mathematics, such as *numerical*, *graphical*, *algebraic*, *symbolic* and *linguistic* registers; and with three

kinds of activities within registers, that are *formation*, *treatment* and *conversion*. Vandebrouck (2011) introduced three perspectives of a function that complement different representations of functions. Punctual or *point-wise* perspective depends only on the value of the function at a single point. *Global* perspective includes function properties that are valid on intervals. Unlike the global perspective that spans universally over points, *local* perspective involves function properties valid in a neighbourhood of a point. Perspectives and registers of representations of a function are related in the following manner: point-wise properties need to be (continuously) interiorized globally to be able to transfer them to local perspective and the comprehensive process of building global perspective of a function is formed primarily on graphical and symbolic representations of a function (Vandebrouck, 2011).

Students' mathematical experience should include activities in multiple registers of representations to enhance the global perspective of functions (Ellis & Grinstead, 2008; Gagatsis & Elia, 2005; Glazer, 2011; Mudaly & Rampersad, 2010) which in return enables students to manipulate with functions as mathematical objects (Baker, Hemenway, & Trigueros, 2001; Gagatsis & Elia, 2005). Duval (1993) named the conversion process starting from the linguistic register and having the treatment (of the problem) done within symbolic, mathematical register as the "mathematization". This process includes observing, recognizing and comprehending the structures and relations that are expressed linguistically and converting those to proper mathematical notions and corresponding expressions. Duval's "mathematization" applies to contextual tasks as the one considered in this paper.

2.1. Task design and research questions

Contextual tasks are commonly found as the "end of the lesson" tasks. Therein tasks are intended to demonstrate the usefulness of the mathematical object and to provide a different setting to exercise mathematical procedures (Barquero, Bosch, & Gascón, 2010; Confrey, 1991; Gravemeijer & Doorman, 1999). The expectation to transparently use some of the (recently) obtained mathematical knowledge to solve a (generally simplified) real-life or contextual problem is named "applicationism" (Barquero *et al.*, 2010). A mathematical task can have learning potential, opportunities and affordances, different from pedagogical potentials intended or assumed by the author or designer of the task (Kieran, Doorman, & Ohtani, 2015; Watson & Thompson, 2015). Interventions in the nature and content of the task can improve its learning opportunities and affordances within the same mathematical context (Watson & Thompson, 2015). However, within the ATD there is a paradigmatic shift about the pedagogical purpose of a mathematical task.

A mathematical body of knowledge is a product of human activity made to solve a problem or answer a question. The path that a researcher goes through to find an appropriate solution includes studying the problem, researching other bodies of knowledge, transposing some knowledge to the given context and creating new knowledge to answer the question. The ATD postulates that students should

acquire knowledge, new to their mathematics education, in the same manner as do the researchers and scientists (Chevallard, 2005, 2012). The suggested approach to learning is called study and research path (SRP). The paradigmatic shift that ATD suggests is to change the mathematics curriculum from a list of objects to be covered to a set of generating questions that induce SRP (Barquero *et al.*, 2010; Chevallard, 2005, 2007, 2012). Contextual tasks, in the ultimate practitioner meaning by Roth (1996), give *raison d'être* of mathematical knowledge and preferably open paths for new questions.

A task design process can follow a general cycle: design – experiment – revision, but the principles of task design depend on the chosen theoretical framework (Kieran *et al.*, 2015; Ruthven, Laborde, Leach, & Tiberghien, 2009). The overall design process should be established in a well organised, coherent and comprehensive initial design and take account of the mathematical body of knowledge, suitable context, educational setting, and other (Ruthven *et al.*, 2009). The ATD provides and suggests many tools that enable theoretically justified design of an SRP, such as praxeology, reference epistemological model (REM) and hierarchy of levels of didactic codetermination (Kieran *et al.*, 2015; Winsløw, 2010; Winsløw, Barquero, Vleeschouwer, & Hardy, 2014). Following the theoretical guidelines, we explore how the nature and the content of the contextual task relate to its learning and pedagogical potentials by considering the following research questions:

- What function properties and features of the model, observed from the point-wise, local and global perspective, have students presented in their answers to the question?
- What activities with the properties of the function and features of the model, observed from the different registers of representation, have students presented in their answers to the question? To be more specific, how have students engaged in the treatment of the properties of the function and the features of the model in graphical, numeric, symbolic and other registers of representation? How have they engaged in the conversion between the linguistic and graphical register or between other registers of representation?

Information obtained from this analysis can be used for further (re)design of the task and to develop a coherent and purposeful study and research path.

3. The context and methodology

3.1. Research setting

We have performed a comprehensive study within the ATD on asymptotes and asymptotic behaviour in the context of upper secondary mathematics education in Croatia (Katalenić, 2017). The study included a praxeological analysis of textbooks for upper secondary mathematics education in Croatia, three questionnaires conducted with university students who are prospective mathematics teachers and

interviews with mathematicians who are both scientists and university educators. We have continuously revised and coordinated the results of the research process with the REM that we proposed.

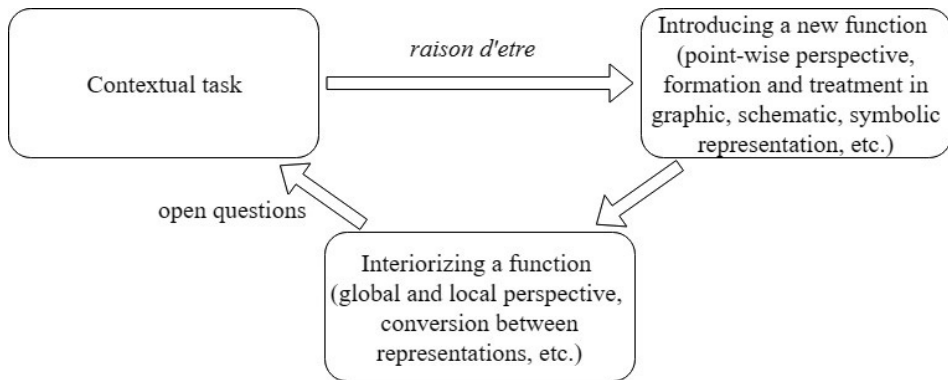

Figure 2. The relations between contextual tasks and functions as a body of knowledge in the REM.

The elementary functions are introduced as isolated items in mathematics curriculum, sometimes related to a mathematical model of some real-life setting (Čižmešija *et al.*, 2017; Serrano, Bosch, & Gascón, 2018). In the proposed REM, we suggest introducing functions when solving some real-life question and using the same context for different types of functions. In that way, the contextual task gives *raison d'être* of a function and developing the function as a new body of knowledge follows the interiorization process described by Vandebrouck (2011). This new body of knowledge is then transposed to answer new questions (Figure 2).

The questionnaires in the study were administered to the whole cohort of the prospective mathematics teachers in the final year of their university education (21 – 23 years of age). The purpose of the questionnaires was to elicit the presence and the state of the asymptote as a body in students' available knowledge. We composed mainly open-ended mathematical tasks and queries to explore different aspects of asymptote as a body of mathematical knowledge. Some of the questions were common or modified tasks from the textbooks for the upper secondary mathematics education. One of those tasks was *a priori* designed to explore the role of an asymptote in graphing and describing an exponential function. Every student who participated in the first questionnaire ($N = 47$) answered this question. We interpreted students' answers as praxeological work through the Vandebrouck's perspectives and Duval's representations.

3.2. A priori analysis of the task

For the purpose of this paper, we outline some features of the ecology of the task, while the detailed textbook analysis can be found in Čižmešija, Katalenić, & Milin Šipuš (2017). There are over one hundred contextual tasks in the textbook section

with exponential and logarithmic functions. The vast majority of those tasks are one or two-step evaluation tasks. We found several tasks on determining the range or to graph the given model. The textbook includes modelling problems mainly as introductory examples. Corresponding formulas derive from the stable quotient between variables. Around half of the contextual tasks in the textbook use the model of exponential growth – e.g. population growth, and around a quarter use the model of exponential decay – e.g. radioactive decomposition. Only a few tasks use the model of bounded exponential growth. We have chosen one of the latter for a questionnaire item in our study. The original and modified versions of the textbook task are given below (Table 1).

The textbook task is located in the exercise block at the end of the textbook section with exponential and logarithmic functions. There are no other instructions, suggestions or discussion for the task. The solution block of the textbook section contains two calculated values. We found that graphing praxeologies in the textbook mainly refer to the exponential functions of the type $a \mapsto a^x$ or $a \mapsto a^{-x}$, $a > 1$, and never to the exponential function of the type $f(x) = b - a^{-x}$ that represents a bounded exponential growth. Common graphing technique in the textbook is plotting points and common discourse about function graph and function behaviour is focused on function monotonicity and graph symmetry at the expense of asymptotic behaviour (Čižmešija *et al.*, 2017).

Table 1. The original textbook task and a modified task for questionnaire.

The textbook task in the authors' translation from Croatian (Gusić, Mladinić, & Pavković, 2008)

It is expected that the percentage of viewers, who will respond to the commercial message for a new product after t days, behaves according to the formula $o(t) = 0.7 - e^{-2t}$.

- (a) What is the percentage of viewers who will respond after 10 days, and what is it after 20 days?
- (b) Graph the function that represents the relationship between the time and percentage of viewers who will respond to the commercial message.
- (c) What is the largest percentage [of viewers] expected to respond?
- (d) Answer the same question if the function given is:
 - a. $o(t) = 0.7 - e^{-4t}$
 - b. $o(t) = 0.9 - e^{-0.1t}$

The modified task from the questionnaire in the authors' translation from Croatian

It is expected that the percentage (expressed as a decimal) of viewers, who will respond to the commercial message for a new product after t days, behaves according to the formula $o(t) = 0.7 - 2^{-t}$.

- (a) Represent the given relationship $o(t)$ graphically.
- (b) What is the expected percentage of viewers who will respond to the commercial message after 7 days?
- (c) Describe the behaviour of the expected percentage of viewers who will respond to the commercial message as days pass.

The chosen textbook task, as well as other tasks in the textbook, is contextual in the simplest sense of the term. A mathematical expression embeds in the real-life situation by providing context to the function values changing over time. Solving and answering the first question of the task does not require reasoning about the context of the situation. The graph of the relationship should comply with the context in the sense that values at stake cannot be negative. The third question of

the task has the largest potential to engage in reasoning about the given model. A meaningful answer emerges from recognizing asymptotic, limiting behaviour of the function that models the given context.

The methodology and the purpose of our broader study had constrained the task (re)design (Katalenić, 2017). We aimed to study textbooks as an institution of knowledge to be taught, whence interventions on the textbook task needed to be minimal. The questionnaires were extensive in order to comprehend various aspects and content that the body of knowledge on asymptote covers. Requirements on the tasks, that were not decisive for eliciting students' available knowledge relevant for the explored body of knowledge, needed to be simplified or reduced. In the case of the chosen textbook task, we had changed the formula from $0.7 - e^{-2t}$ to $0.7 - 2^{-t}$, since the latter was judged more familiar and easier for the point-wise evaluation and algebraic manipulation. Further, we maintained the graphing request and changed the request to evaluate the model. In the modified task, the function value for $t = 7$ and the function limit differ in thousandths.

The major intervention in the task was to replace the question that addresses the largest expected value with a question about the behaviour of the model. We preferred an open task, to give students an opportunity to state conceptions and ideas they find relevant, which would enable an insight into their description of the asymptotic behaviour of the given function. A detailed analysis of the state of the asymptote in students' graphing praxeologies is a part of an ongoing study.

4. Results

We observed that, apart from the graphing *praxis*, the students' work differentiates in several features that inform us about their discourse of model and function recognition, interpretation and representation. Those features correspond to a global, local or point-wise perspective of a function as described in Table 2. All features of the students' productions were analysed and organized according to the perspectives of a function and situated within the graphical, numerical, symbolic or discursive, that is linguistic with the formal mathematics, register of representation.

Table 2. Features of students' graphed model arranged according to the perspectives of a function.

Global properties	Local properties	Point-wise properties
<ul style="list-style-type: none"> ● concave, convex graph or graph in an unspecified shape ● increasing/decreasing graph ● bounded/unbounded graph 	<ul style="list-style-type: none"> ● behaviour at infinity – unavailable or approaching the number 0.7 ● behaviour around distinct points – continuous or endpoint of the domain 	<ul style="list-style-type: none"> ● values at distinct or plotted points of the graph – the ordinate value for independent variables $x = 0$ or $x = 1$, and the value of y-intercept

4.1. The global perspective of the function

Observing from the global perspective of the function and referring to the graphical and discursive registers, we can categorize students' representations of the model

with the following labels (Table 3):

1. bounded exponential growth – the produced graph is concave, the values of the function are increasing and bounded from above by some fixed number,
2. bounded growth – the shape of the produced graph is unspecified, the values of the function are increasing and bounded from above by some fixed number (Figure 3),
3. “logarithmic” growth – the produced graph is concave, the values of the function are increasing and not bounded, that is, the graph resembles the logarithmic function graph above the x -axis.

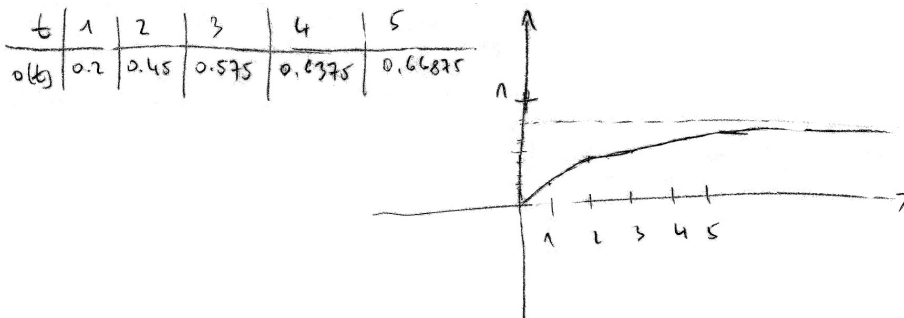

Figure 3. Representation of the model that is bounded from above by the horizontal asymptote with unspecified global shape and zero of the function at the origin.

Other representations include graphs of an exponential decay where a student claimed that the values “will decrease as days go by, but it will never reach 0.7”, or an exponential growth where a student claimed that an increase in the values is “not linear but exponential”, and lines and curves that did not fit any of the above categories.

Table 3. Frequencies of the observed features in the students’ representations of the model from the global and local perspective of a function.

Type of graph	Zero at $t \approx 0.5$	Endpoint at 1	Endpoint at 0	Zero at origin	No endpoint	Σ
Bounded exponential growth toward 0.7	2	8	6	1	5	22
Bounded growth toward 0.7	1	2	1	3	1	8
“Logarithmic growth”	2		3		1	6
Bounded exponential growth			2			2
Other	1	2	2		4	9
Σ	6	12	12	6	11	47

Majority of the students represented the function by a global shape of a concave, increasing graph. Students' representations differ with respect to the boundedness and the horizontal asymptote of the function (Table 4). Those representations intertwine the global and local perspectives of the function, and they are accessed from the students' graphs and descriptions.

Table 4. Frequencies of the observed features in students' graphical and discursive representation of the function.

Graph	Description of values				
	Increasing with some limit value	Limit value 0.7	Increasing only	Other	Σ
Bounded from above by an asymptote	14	5	2	1	22
Ends at a particular point	4	3	3		10
Unbounded from above	2	1	10		13
Other		1		1	2
Σ	20	10	15	2	47

Students who graphed a curve that ends at some particular point, whence the behaviour at infinity is graphically unavailable, wrote that the values are increasing or approaching the number 0.7, or both. For example, one student wrote (Figure 4):

“Until the 3rd day that percentage jumps quickly, it increases, but after the 4th day, the percentage increases slowly. That is, after the 4th day, that percentage will be constant and equal just about 70%.”

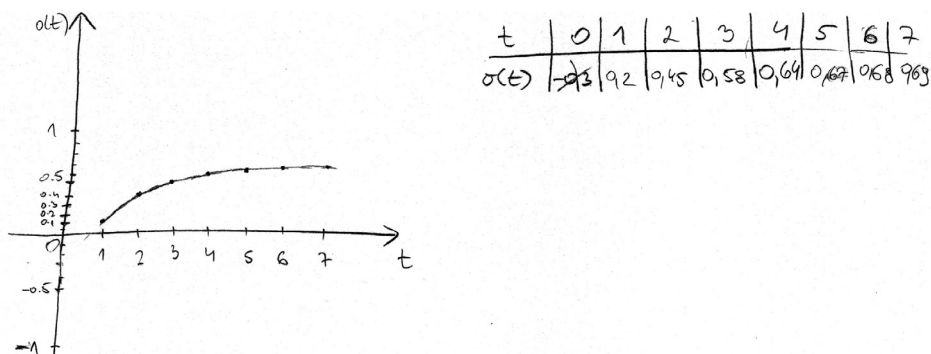

Figure 4. Representation of the model that ends at the point $t = 7$ with the endpoint of the domain at $t = 1$.

Students have complemented the graphical representation of an unbounded function with two different discourses. To support the representation, for this purpose, named “logarithmic growth”, we found that a student wrote that the values

Students used the following models of limit: dynamic and static model, model of limit as a bound or as stabilization of values and formal limit. Majority of students used the model of limit as a bound and dynamic model to describe the function limiting behaviour (Table 5). Among students who used any model to describe limiting behaviour, the share of those who drew a horizontal asymptote is largest in the group of students who used the model of limit as a bound, followed by the group of students who used the formal limit. The smallest such share, less than half of the students involved, is in the group of students who used the model of limit as stabilization of values.

Table 5. Frequencies of different models of limit that students used compared to the corresponding number of students who graphed a horizontal asymptote.

Model of limit	Number of students	
	Total	Horizontal asymptote
Bound	18	15
Dynamic	17	10
Formal limit	9	6
Stabilization of values	5	2
Static	4	2

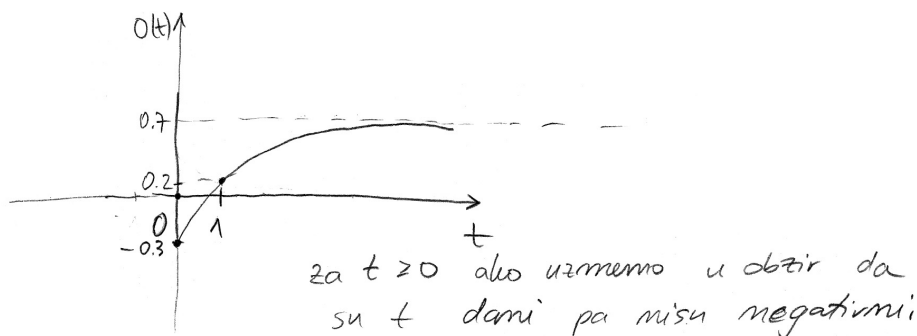

Figure 7. Representation of the model that is concave, increasing and bounded from above by the horizontal asymptote, with the endpoint of the domain at $t = 0$ and discourse on the model domain.

From the local perspective of a function, students' representations differ by their choice of the endpoint and the zero of the function. In the students' productions, the numbers $t = 0$, $t = 1$ and the zero of the function $t = -\log_2 0.7 \approx 0.5$, are either endpoints of the domain or the function is continuous at these points – in the sense that both left and right sided limits are available (Table 3). Students justified their choice for the endpoint of the domain by referring to the linguistic register. They interpreted which value the independent variable t , as a measure for “a day”, could obtain. For some students, “days” must be nonnegative whence the endpoint is in $t = 0$ (Figure 7), while others claim the changes “start after the first day” whence the endpoint is $t = 1$ (Figure 8). Some students have graphed

the model so that it had an endpoint and a zero of the function at the origin (Figure 3). Among the students who graphed the model with the endpoint at the zero of the function, some have neglected the part of the graph initially drawn under the abscissa axis with the claim that it makes “no sense because the percentage is pos. record” (Figure 5). A student crossed out the negative value of the function at $t = 0$ in the table of values but erased the part of the graph (continuously) from $t = 0$ to $t = 1$ (Figure 4).

4.3. The point-wise perspective of a function

From the point-wise perspective of a function, students mainly engaged in function evaluation within the numerical register. Majority of students calculated (correctly) function values at $t = 1$, $t = 0$ and other points. Some students argued that the graph is a dot plot since the independent variable stands for “days”, whence t has integer values. Students evaluated the function to find the expected percentage of viewers who will respond to the commercial message after 7 days. They presented the calculated values as a correct decimal number or a fraction, as a rounded decimal number or percentage or as a decimal approximation or approximate percentage.

The point-wise perspective of a function interfered with other registers of representation. Some students engaged with the *praxis* of finding zeros of the function in the algebraic register, however, none of them wrote an approximate value of the zero, while some of them graphed that zero approximately at 0.5 (Figure 5). A student noticed that the value of the fraction 2^{-8} is very small, hence the function value at $t = 8$ is approximately 70 %. Several other students made similar arguments in the symbolic register in their description of the model (Figure 8).

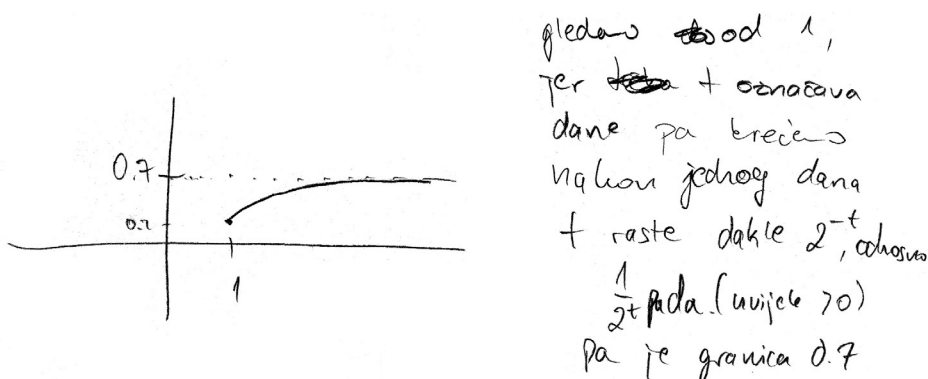

Figure 8. Representation of the model that is concave, increasing and bounded from above by the horizontal asymptote, with the endpoint of the domain at $t = 1$ and discourses on the model domain and range.

5. Discussion and conclusion

5.1. Discussing the students' work through the lenses of the perspectives of a function

Considering the features of the students' graphical representation, their work in this task has lacked the mathematical expertise with elementary functions. There were several issues with the produced graphs regarding the global graph shape. If the drawn graph ends at some particular point, then the local and global perspectives of the function, that is, behaviour at infinity, graph shape and boundedness, are unavailable. If the drawn graph has an unspecified graph shape, due to the imprudent connecting of the plotted points, then the interiorization process of the concavity as a global property of the exponential function of the type $f(x) = b - a^{-x}$, is not accomplished. The predominance of the point-wise over the global perspective of a function was notable, for example, in the case when the graph was the dot plot and even when the graph presented the bounded exponential growth (Figure 3 and Figure 8). The drawn graphs resembling the logarithmic growth might indicate the lack of experience with different types of exponential functions, especially with the bounded exponential growth.

The local and point-wise perspectives of the students' graphs revealed issues with the asymptotic behaviour, zeros and endpoint of the function. The lack of the discourse about the asymptotic behaviour and the previous work with standard types of exponential function found in mathematics textbooks (and education), could have conditioned that students omitted to draw a horizontal asymptote, and even that they drew an exponential growth. Furthermore, the asymptote misconception, recognized from the students' drawing of a curve and its asymptote with a fixed distance between them, was manifested with other functions in other studies (Katalenić, 2017; Öçal, 2017).

The issues students have shown with the zeros of the function and the endpoint of the domain could be due to a complex *praxis* of finding the zeros compared to the evaluation of the function in other points, or a naive conception of drawing a curve through the origin reported in other studies (Glazer, 2011). Due to the nature and the content of the task, some issues in the different perspectives can be affected by the conversion from linguistic to graphical register.

5.2. Discussing the students' work through the lenses of the registers of representations

In their work, students had to convert between the linguistic and symbolic register and coordinate numerical, algebraic, symbolic, graphical and discursive registers. The context of the task may have prompted students that the values are increasing, but it also may have caused a misinterpretation of the domain and range of the function restricted by the model. Having "days" as the independent variable could have induced the students' point-wise perspective of the model and choosing $t = 0$ or $t = 1$ as the endpoint of the domain. There is evidence in the students' work

that the latter misinterpretation emanates from the two-step restriction on the model values (both time and percentage are nonnegative values), the complexity of the *praxis* of finding the zeros of the function and the familiarity with models that have similar restrictions.

Students perceived the function limiting behaviour better in the discursive than in the graphical register. The treatment within the numerical register did not seem to be decisive in recognizing the limiting behaviour. The discursive representation of the function values as “stabilizing” appeared to be weakly related to the graphical (and symbolic) representation of the horizontal asymptote. This is adverse to the results of a study performed by Kidron (2011), where a student uncovered the formal definition of a horizontal asymptote building on the stabilization of values in the numerical register. Adding on, even though the asymptotic misconception is evident only in the graphical representation, we believe that it is conditioned by the lack of coordination between the discursive, symbolic and numerical registers when interiorizing the local property of the asymptotic behaviour.

The task provided opportunities to engage with different representations of the model. Students were more confident with treatment within each register than with conversion or the coordination between registers of representation. Such observations imply the need for including corresponding requests in the task or to purposefully train students in such activities as proposed by Gagatsis & Elia (2005). Our findings are in line with other studies that suggest the reinforcement of the treatment within discursive register and coordination of other registers with numerical register from the local and global perspective (Baker *et al.*, 2001; Ellis & Grinstead, 2008; Glazer, 2011).

6. Guidelines for further design

The pedagogical purpose and learning opportunities of the original textbook task are abstruse. The absence of tasks and discourse about function behaviour in the textbook indicate that the pedagogical purpose of the task as a standalone exercise task is questionable. However, considering the features of students’ work in the question, the learning potential of the task is significant as it engages different aspects of students’ praxeological equipment with exponential functions. Some of them are graphing praxeology, the *praxis* of finding zeros of the function, purposeful evaluation *praxis*, and discourse about the domain, range and restriction on values, interiorization of *logos* about graph shape, boundedness and limiting behaviour as global and local properties of bounded exponential growth. In order to actualize the learning potentials of the task, the teacher must critically evaluate the designers’ intentions with a task (Watson & Thompson, 2015) and formally assess students’ work to gain insight into their activities with different registers (Duval, 1993).

Rich learning opportunities of the task are aligned with the idea of an SRP that any mathematical activity should include a wide range of praxeologies and open

the paths for new mathematical knowledge (Barquero *et al.*, 2010). The pedagogical purpose of an SRP is to pose (generating) question that engages students in progress of queries throughout which they produce a new body of knowledge or *raison d'être* emerges for a new body of knowledge. The context of a mathematical task should be familiar to students, reflect on real practices and provide meaningful treatment with the mathematical content of the task (Confrey, 1991; Roth, 1996). We direct our further work towards finding appropriate questions and context that could generate models with bounded exponential or logistic growth.

References

- [1] BAKER, B., TRIGUEROS, M., & HEMENWAY, C. (2001). On transformation of functions. In R. Speiser, C. A. Maher, & C. N. Walter (Eds.), *Proceedings of the twenty-third annual meeting of the North American Chapter of the International Group for the Psychology of Mathematics Education* (Vols. 1–2) (pp. 91–98), Columbus, OH: ERIC Clearinghouse for Science, Mathematics, and Environmental Education.
- [2] BARQUERO, B., BOSCH, M., & GASCÓN, J. (2010). The ‘ecology’ of mathematical modelling: Constraints to its teaching at university level. In V. Durand-Guerrier, S. Soury-Lavergne, & F. Arzarello (Eds.), *Proceedings of the Sixth Congress of the European Society for Research in Mathematics Education* (pp. 2146–2155), Lyon France: Institut national de recherche pédagogique.
- [3] CHEVALLARD, Y. (2006). Steps towards a new epistemology in mathematics education. *Proceedings of the Fourth Congress of the European Society for Research in Mathematics Education*, 21–30, Sant Feliu de Guíxols, Spain.
- [4] CHEVALLARD, Y. (2007). Readjusting Didactics to a Changing Epistemology. *European Educational Research Journal*, 6(2), 131–134.
- [5] CHEVALLARD, Y. (2015). Teaching Mathematics in tomorrow’s society: a case for an oncoming counter paradigm. In *The proceedings of the 12th international congress on mathematical education* (pp. 173–187). Springer, Cham.
- [6] ČIŽMEŠIJA, A., KATALENIĆ, A., & MILIN ŠIPUŠ, Ž. (2017). Asymptote as a body of knowledge to be taught in textbooks for Croatian secondary education. In Ž. Kolar-Begović, R. Kolar-Šuper, & L. Jukić-Matić (Eds.), *Mathematics education as a science and a profession*, pp. 127–147, Osijek: Element.
- [7] CONFREY, J. (1991). The Concept of Exponential Functions: A Student’s Perspective. In L. P. Steffe (Ed.), *Epistemological Foundations of Mathematical Experience*, pp. 124–159, New York: Springer.
- [8] DUVAL, R. (1993). Registres de représentation sémiotique et fonctionnement cognitif de la pensée [Registers of semiotic representation and cognitive functioning of thinking]. *Annales de La Didactique et de Sciences Cognitives*, 5(1), 37–65.
- [9] ELLIS, A. B., & GRINSTEAD, P. (2008). Hidden lessons: How a focus on slope-like properties of quadratic functions encouraged unexpected generalizations. *The Journal of Mathematical Behavior*, 27(4), 277–296.

- [10] GAGATSIS, A., & ELIA, I. (2005). A review of some recent studies on the role of representations in mathematics education in Cyprus and Greece. *Proceedings of the Fourth Congress of the European Society for Research in Mathematics Education*, 102–111. Saint Feliu de Guixols, Spain: ERME.
- [11] GLASNOVIĆ GRACIN, D., & JUKIĆ MATIĆ, L. (2016). The Role of Mathematics Textbooks in Lower Secondary Education in Croatia: An Empirical Study. *The Mathematics Educator*, 16(2), 31.
- [12] GLAZER, N. (2011). Challenges with graph interpretation: a review of the literature. *Studies in Science Education*, 47(2), 183–210.
- [13] GRAVEMEIJER, K., & DOORMAN, M. (1999). Context Problems in Realistic Mathematics Education: A Calculus Course as an Example. *Educational Studies in Mathematics*, 39(1), 111–129.
- [14] GUSIĆ, J., MLADINIĆ, P., & PAVKOVIĆ, M. (2008). *Matematika 2, 2. dio, udžbenik sa zbirkom zadataka za 2. razred opće, jezične i klasične gimnazije*. Zagreb: Školska knjiga.
- [15] JUKIĆ MATIĆ, L., & GLASNOVIĆ GRACIN, D. (2016). The use of the textbook as an artefact in the classroom. *Journal Für Mathematik-Didaktik*, 37(2), 349–374.
- [16] KATALENIĆ, A. (2017). *Asimptota i asimptotsko ponašanje – didaktička transpozicija objekta znanja u gimnazijskom obrazovanju u Republici Hrvatskoj [Asymptote and asymptotic behavior – didactic transposition in general secondary education in Croatia]* (Doctoral thesis). Faculty of Science, Department of Mathematics, Zagreb.
- [17] KIDRON, I. (2011). Constructing knowledge about the notion of limit in the definition of the horizontal asymptote. *International Journal of Science and Mathematics Education*, 9(6), 1261–1279.
- [18] KIERAN, C., DOORMAN, M., & OHTANI, M. (2015). Frameworks and Principles for Task Design. In A. Watson & M. Ohtani (Eds.), *Task Design In Mathematics Education*, pp. 19–81, Cham: Springer International Publishing.
- [19] KOP, P. M. G. M., JANSSEN, F. J. J. M., DRIJVERS, P. H. M., & VAN DRIEL, J. H. (2017). Graphing formulas: Unraveling experts' recognition processes. *The Journal of Mathematical Behavior*, 45, 167–182.
- [20] MUDALY, V., & RAMPERSAD, R. (2010). The role of visualisation in learners' conceptual understanding of graphical functional relationships. *African Journal of Research in Mathematics, Science and Technology Education*, 14(1), 36–48.
- [21] ÖÇAL, M. F. (2017). Asymptote Misconception on Graphing Functions: Does Graphing Software Resolve It? *Malaysian Online Journal of Educational Technology*, 5(1), 21–33.
- [22] ROTH, W.-M. (1996). Where Is the Context in Contextual Word Problems?: Mathematical Practices and Products in Grade 8 Students' Answers to Story Problems. *Cognition and Instruction*, 14(4), 487–527.
- [23] RUTHVEN, K., LABORDE, C., LEACH, J., & TIBERGHIE, A. (2009). Design Tools in Didactical Research: Instrumenting the Epistemological and Cognitive Aspects of the Design of Teaching Sequences. *Educational Researcher*, 38(5), 329–342.
- [24] SERRANO, L., BOSCH, M., & GASCÓN, J. (2018). An overview of “bridging courses” from the ATD perspective. Presented at *The 6th International Conference on the Anthropological Theory of the Didactic*, Grenoble, France.

- [25] VANDEBROUCK, F. (2011). Perspectives et domaines de travail pour l'étude des fonctions [Perspectives and working domains for functions' studies]. *Annales de Didactiques et de Sciences Cognitives*, 16, 149–185.
- [26] VERSCHAFFEL, L., DEPAEPE, F., & DOOREN, W. V. (2014). Word Problems in Mathematics Education. In S. Lerman (Ed.), *Encyclopedia of Mathematics Education*, pp. 641–645, Dordrecht: Springer.
- [27] WATSON, A., & THOMPSON, D. R. (2015). Design Issues Related to Text-Based Tasks. In A. Watson & M. Ohtani (Eds.), *Task Design In Mathematics Education*, pp. 143–190, Cham: Springer International Publishing.
- [28] WINSLØW, C. (2010). Anthropological theory of didactic phenomena: some examples and principles of its use in the study of mathematics education. Presented at the *Annual Conference of the Finnish Association for Research in Mathematics and Science Education*.
- [29] WINSLØW, C. (2013). The Transition from University to High School and the Case of Exponential Functions. *Proceedings of the Eighth Congress of the European Society for Research in Mathematics Education*, 2476–2485. Antalya, Turkey.
- [30] WINSLØW, C., BARQUERO, B., VLEESCHOUWER, M. D., & HARDY, N. (2014). An institutional approach to university mathematics education: from dual vector spaces to questioning the world. *Research in Mathematics Education*, 16(2), 95–111.

Contact addresses:

Aleksandra Čizmešija
Faculty of Science, University of Zagreb
Bijenička cesta 30, 10000 Zagreb, Croatia
e-mail: cizmesij@math.hr

Ana Katalenić
Faculty of Education, University of Osijek
Cara Hadrijana 10, 31000 Osijek, Croatia
e-mail: akatalenic@foozos.hr

Željka Milin Šipuš
Faculty of Science, University of Zagreb
Bijenička cesta 30, 10000 Zagreb, Croatia
e-mail: milin@math.hr

Redizajniranje kontekstualnog udžbeničkog zadatka s funkcijom eksponencijalnog tipa pomoću *a posteriori* analize radova studenata nastavničkog studija matematike

Željka Milin Šipuš¹, Aleksandra Čižmešija¹ i Ana Katalenić²

¹Prirodoslovno-matematički fakultet, Sveučilište u Zagrebu, Hrvatska

²Fakultet za odgojne i obrazovne znanosti, Sveučilište u Osijeku, Hrvatska

Sažetak. Eksponencijalna funkcija je jedna od temeljnih funkcija u matematičkom modeliranju i uglavnom je dijelom kurikulumu srednjoškolskog matematičkog obrazovanja. Horizontalna asimptota je istaknuto svojstvo grafa eksponencijalne funkcije. Proveli smo opsežnu studiju unutar Antropološke teorije didaktike o asimptoti i asimptotskom ponašanju u kontekstu srednjoškolskog matematičkog obrazovanja u Hrvatskoj. Dio te studije čine upitnici s budućim učiteljima matematike. Jedno od pitanja iz upitnika je *a priori* dizajnirano za ispitivanje uloge asimptote u crtanju i opisivanju eksponencijalne funkcije. U ovom radu, predstavljamo rezultate *a posteriori* analize studentskih uradaka na izmijenjenom udžbeničkom zadatku s funkcijom eksponencijalnog tipa. Raspravljamo o svojstvima udžbeničkog i redizajniranog zadatka te donosimo prijedloge za izbor i dizajn zadataka koji doprinose razvijanju koherentnosti i diskursa u matematičkom znanju studenata.

Ključne riječi: antropološka teorija didaktike, *a posteriori* analiza, dizajn zadataka, eksponencijalna funkcija, graf funkcije, kontekstualni zadatak

Investigating adaptive reasoning and strategic competence in Croatian mathematics education: The example of quadratic function

Matea Gusić

Faculty of Teacher Education, University of Zagreb, Zagreb, Croatia

Abstract. Since the 1980s many mathematics educators have emphasized that being able to use computational procedures accurately and quickly, or reproduce large quantities of knowledge, isn't sufficient for students to be mathematically proficient. The development of students' reasoning and problem-solving skills, as well as the ability to connect and communicate mathematical ideas came into focus. One of the frameworks which considers a more comprehensive approach to mathematics learning is *mathematical proficiency* by Kilpatrick, Swafford and Findell. Mathematical proficiency proposes five equally important and mutually interdependent strands. This paper aims to investigate two of the strands: *adaptive reasoning* and *strategic competence* in Croatian mathematics education regarding quadratic functions. The objective is to gain insight into curriculum requirements and students' skills, explore indicators of adaptive reasoning and strategic competence and thus reach a deeper understanding of the situation. One of the most commonly used textbooks in high school mathematics in Croatia has been analysed with the purpose of determining the extent and the nature to which textbooks enable opportunities for the development of these strands regarding quadratic functions. A case study with three second-grade gymnasium students was conducted to gain insight into the adaptive reasoning and strategic competence skills activated while solving quadratic function tasks.

Keywords: mathematical proficiency, adaptive reasoning, strategic competence, quadratic function, textbook analysis, case study

1. Introduction

Until the 1980s the learning of mathematics was mostly connected to students' ability to use computational procedures accurately and quickly, and the ability to reproduce large quantities of knowledge. Then a shift towards reasoning, problem solving, connecting and communicating mathematical ideas took place (Kilpatrick, Swafford & Findell, 2001). This shift did not mean that knowledge was no longer important. Anyone lacking a grasp of facts, procedures, definitions and concepts is clearly restricted in dealing with mathematics. The shift meant that merely having knowledge isn't enough, that being proficient in mathematics signifies much more than being able to reproduce content (Schoenfeld, 2007). In this sense, the mathematical proficiency of a person could be described as what one knows, can do, and is disposed to do in mathematics. Although knowledge does have a central role in doing mathematics, an individual's ability to tackle problems using appropriate problem-solving strategies, to use their knowledge and to have positive beliefs and disposition about mathematics are also critically important (Schoenfeld, 2007).

Kilpatrick et al. (2001) define mathematical proficiency as a comprehensive view of successful mathematics learning. Mathematical proficiency has five, equally important and mutually interdependent components, or strands: conceptual understanding, procedural fluency, strategic competence, adaptive reasoning, and productive disposition. The strands represent different aspects of a complex whole, which enable the development of mathematical proficiency. Therefore, achieving students' mathematical proficiency requires focusing on all five strands. *Conceptual understanding* is a comprehension of mathematical concepts, operations, and relations. *Procedural fluency* is skill in carrying out procedures flexibly, accurately, efficiently and appropriately. *Strategic competence* is the ability to formulate, represent, and solve mathematical problems. *Adaptive reasoning* is the capacity for logical thought, reflection, explanation, and justification. This kind of reasoning is a much broader notion than proof and other forms of deductive reasoning. It includes different forms of informal explanations as well as intuitive and inductive reasoning based on pattern, analogy and metaphor. *Productive disposition* is defined as the habitual inclination to see mathematics as sensible, useful, and worthwhile, coupled with a belief in diligence and one's own efficacy.

Research has shown that rule-based teaching doesn't provide students with opportunities to create meaning for the rules, just when to use them. This can lead to forgetting, unsystematic errors, and poor strategic decisions (Kilpatrick et al., 2001). On the contrary, students who learn mathematics in more broad-based curricula show reasonably good results on tests of skills and do much better on assessments of conceptual understanding and problem solving (Groves, 2012). From which can be concluded that increasing opportunities for the development of conceptual understanding, as well as adaptive reasoning and strategic competence skills, can only be beneficial.

This paper will focus on two of these strands: adaptive reasoning and strategic competence. The importance of mathematical proficiency is recognised, and included in curricular documents, by some countries (e.g. Australia and Singapore).

Current Croatian curricular documents, including textbooks, do not put emphasis on adaptive reasoning or strategic competence explicitly. Furthermore, adaptive reasoning and strategic competence in the field of quadratic function have not been studied in Croatia so far. The aim of this paper is to gain insight into the development of adaptive reasoning and strategic competence in the field of quadratic functions. In order to achieve this, indicators of adaptive reasoning and strategic competence are explored, and some phenomena that might enable deeper understanding of the situation are identified. Related to this aim, two research questions have been formed: Which characteristics of adaptive reasoning, and to what extent, can be identified in the field of quadratic function? Which characteristics of strategic competence, and to what extent, can be identified in the field of quadratic function?

In the first section of this paper, the theoretical perspective regarding adaptive reasoning and strategic competence will be presented. In the following section, tasks regarded as potentially promoting adaptive reasoning and strategic competence will be defined. Then, the methodology and the results of the study will be presented, followed by the discussion, which aims to respond to the above-stated research questions.

2. Adaptive reasoning and strategic competence

2.1. Adaptive reasoning in mathematics education

Adaptive reasoning refers to the capacity to think logically about the relationships among concepts and situations. One uses it to navigate through the many facts, procedures, concepts, and solution methods and to see that they all fit together in some way, that they make sense (Kilpatrick et al., 2001, p. 129). According to Kilpatrick (2011), the term adaptive reasoning includes more than just logical and deductive reasoning. The term also involves other kinds of reasoning, such as inductive or plausible reasoning, informal and intuitive explanations based on pattern, analogy, and metaphor. One of the manifestations of adaptive reasoning is the students' ability to justify their work in the sense of offering a sufficient reason or suggesting the source of reasoning, and to have experience of doing so in many different problems (Kilpatrick et al., 2001). It is important to stress that to be considered as adaptive reasoning must be correct and valid, and the student has to be able to justify it (Kilpatrick et al., 2001).

The Australian Curriculum (ACARA, n.d.) for mathematics connects mathematical reasoning with the capacity of logical thought and a set of skills, such as analysing, proving, evaluating, explaining, deducing, justifying and generalising. Students are reasoning mathematically when they:

1. explain their thinking;
2. deduce and justify strategies used or reached conclusions;

3. adapt the known to the unknown or transfer knowledge from one context to another;
4. prove claim to be true or false, and
5. compare and contrast related ideas and explain their choices.

Boesen, Lithner and Palm considered two possible types of students' reasoning in problem solving situations: *imitative* and *creative mathematically founded* reasoning. Imitative reasoning is considered as using memorization or well-rehearsed procedures, while creative mathematically founded reasoning is defined as "novel reasoning with arguments to back it up and anchored in appropriate mathematical foundations" (as cited in Breen and O'Shea, 2010, p. 43). Hence, creative mathematically founded reasoning can be considered as adaptive reasoning, while imitative reasoning, which uses so called "lower level skills, such as memorization and the routine application of algorithms or procedures" (Breen and O'Shea, 2010, p. 39), doesn't fit the description of adaptive reasoning.

There are three necessary conditions for students to be able to reason adaptively: students have to have a sufficient knowledge base, tasks need to be understandable and motivating and the context familiar and comfortable (Kilpatrick et al., 2001).

In the line with the presented literature review regarding adaptive reasoning in mathematics education, in this paper, indicators of adaptive reasoning are behaviours such as: providing intuitive explanations, justifications of one's own work or reached conclusions and transfer of knowledge. Transfer of knowledge is particularly important for the concept of function, since it is connected to multiple representations. For example, the interpretation of meaning of the same function concept in different representations (e.g. from verbal description "maximal value of given quadratic function is 9", one deduces that ordinate of vertex of parabola is 9, and also that for the given function $f(x) = a(x - x_0)^2 + 9$ is true). Adaptive reasoning is also indicated with the ability to justify or prove a general argument, meaningful navigation through many procedures and concepts and with correct and valid inductive and deductive reasoning. The list of indicators of adaptive reasoning considered in this paper is presented in Appendix A.

2.2. Strategic competence in mathematics education

Strategic competence refers to the ability to formulate mathematical problems, represent them and solve them. This strand is similar to what has been called problem solving and problem formulation in the literature of mathematics education and cognitive science (Kilpatrick et al., 2001, p. 124).

According to Butler, strategic learning involves "a recursive cycle of cognitive activities including analysing tasks; selecting, adapting, or even inventing strategies; monitoring performance; and shifting approaches as required" (as cited in Özdemir and Pape, 2012, p. 156).

Özdemir and Pape (2012) define strategic competence in the sense of the self-regulated learning theory. Self-regulated learning strategies are “actions directed at acquiring information or skill that involve agency, purpose (goals), and instrumentality self-perceptions by a learner” (Zimmerman and Martinez-Pons, 1986, p. 615). Strategic competence is defined as students’ efforts to regulate their learning behaviours as they participate within classroom practices. Therefore, strategic competence includes knowing and employing strategies to analyse and complete tasks and activities or to solve problems with the goal of learning mathematics content (Özdemir and Pape, 2012, p. 154). Self-regulated learners are considered strategically competent, because they demonstrate the use of cognitive, metacognitive as well as elaboration and organisational strategies. *Cognitive strategies* are considered as seeking, organizing and transforming information, as well as rehearsing and memorizing acquired knowledge or skills. *Metacognitive strategies* include the monitoring of one’s own work: goal setting, planning and regulating. And *elaboration and organizational strategies* refer to the reorganization and reconnection of ideas with the goal of reaching deeper understanding. Less strategically competent learners demonstrate only the use of basic rehearsal strategies, such as copying, and highlighting, that enable only selecting and acquiring information, but not comprehension at a more conceptual level (Özdemir and Pape, 2012).

Pape and Wang (2003) identified twelve categories of strategic behaviour that students demonstrate in mathematical classroom practice. In this paper only five categories, those that students demonstrate in the individual problem-solving process, are considered. Applicable categories of strategic behaviour that indicate strategic competencies are:

1. *Self-evaluating*, meaning self-initiated checking of the quality and correctness of their work (e.g. checking the answers, redoing the problems, reviewing taken steps);
2. *Organizing and transforming*, meaning organization and representation of a given problem with aim of achieving understanding or facilitation of a given problem (e.g. using manipulative materials or visual aids for understanding, formation of a mental model, breaking down the model, writing down the steps) or to reach a deeper understanding;
3. *Goal-setting and planning*, meaning the planning of the problem-solving process, including conscious choosing of the most appropriate strategy;
4. *Seeking information*, meaning searching for further task information that could be useful in problem solving (e.g. multiple reading of the task, indication of key words, returning to the problem);
5. *Keeping records and monitoring*, meaning regulating one’s own work (showing and labelling each step, rechecking calculation) to assure that correct work and results are recorded.

Kilpatrick et al. (2001) state that the student’s first step, when presented with a problem, is to represent it mathematically (numerically, symbolically, verbally, or

graphically). This requires the student to understand the situation, and to construct a mathematical representation of it, including key features and ignoring irrelevant ones. Constructing a mental problem model (not necessarily a visual picture, but any form of mental representation that maintains the structural relations among the variables in the problem) is considered a more proficient approach to problem solving (Kilpatrick et al., 2001). Therefore, it is an indicator of strategic competence, which is in the accordance with the “organizing and transforming” strategic behaviour.

Strategic competence is indicated when a student consciously replaces procedures that have been helpful at the beginning of his learning, or that they have more experience with, with more efficient, but maybe cognitively more complex ones (Kilpatrick et al., 2001). Ostler (2011) stresses the importance of problems in school mathematics that provide more than one possible approach. These problems have a strong influence on strategic thinking. Strategic behaviour is indicated when a student considers efficiency when choosing strategy, and does not just apply recently learned or the most familiar skills. This is in accordance with the “goal-setting and planning” category of strategic behaviour. Strategic thinking can also be activated in a situation where the student is presented with multiple solutions of the same problem, using different solving strategies, and left to select the most efficient method for similar kinds of tasks (Ostler, 2011).

In the line with the presented literature review regarding strategic competence in mathematics education, in this paper, indicators of strategic competence are the five categories of behaviours defined by Pape and Wang (2003) previously mentioned and the ability to formulate problems, as defined by Kilpatrick et al. (2001). The list of indicators of strategic competence considered in this paper is presented in Appendix A.

3. Adaptive reasoning and strategic competence in tasks

Research has shown that the types of tasks assigned to students highly influence the kinds of thinking and processes in which they engage, their level of engagement, and, thus, the learning outcomes achieved (Breen and O’Shea, 2018, p. 1). Therefore, it seems necessary to consider what kind of tasks promote the activation of adaptive reasoning and strategic skills.

There are three main types of school algebra activities: *representational* activities, *transformational* (rule-based) activities, and *generalizing and justifying* activities (Kilpatrick et al., 2001). Transformational activities, being linked to the changing the form of expression, and using the rules for manipulation of algebraic expressions, such as factoring and solving equations, are considered as procedural activities. That is, activities that do not promote adaptive reasoning or strategic competence. Generalizing and justifying, as activities that include problem solving, modelling, justifying, proving, and predicting, are considered as activities that promote all the strands of mathematical proficiency, especially adaptive reasoning

(Kilpatrick et al., 2001). Hence, all the activities requiring explanations, justifications, proving, predicting or modelling, are considered as promoting adaptive reasoning. Representational activities of algebra involve translating verbal information into symbolic expressions. For example, generation of rule or formula of the function governing numerical relationship (given with or without context), as well as functions describing geometrical patterns and numerical sequences (Kilpatrick et al., 2001). These activities require conceptual understanding as well as the strategic competence of formulating and representing (Kilpatrick et al., 2001). Since representational activities include multiple representation, they are promoting transfer of knowledge, i.e. adaptive reasoning. Hence, representational activities are considered as promoting both adaptive reasoning and strategic competence.

Breen and O'Shea (2018) state six types of activities that promote effective mathematical thinking: generating examples, analyzing reasoning, evaluating mathematical statements, conjecturing and/or generalizing, visualizing and using definitions. Sangwin characterises tasks that require students to construct an instance, criticize a fallacy or to prove, show and justify a general argument as tasks promoting adaptive learning (as paraphrased in Breen and O'Shea, 2018). Stein, Grover and Henningsen identify tasks that show potential for multiple representations, the existence of multiple solution-strategies, and the extent to which the task demands explanations and/or justifications to be tasks that promote thinking, reasoning and sense making (as paraphrased in Breen and O'Shea, 2018).

Kilpatrick et al. (2001) stress the importance of non-routine problems for the development of adaptive reasoning and strategic competence. While routine problems only require reproductive thinking, because a learner can rely on their past experience to solve a problem, non-routine problems require learners to understand the problem and invent a way to solve it. Authors (e.g. Yeo, 2007; Breen and O'Shea, 2010) characterize routine tasks as those that can commonly be found in textbooks. Yeo (2007) argues that although a routine task for some students presents merely the application of procedural skill learned earlier, for low ability students, or those unfamiliar with the required procedure, the task could present a true mathematical problem. Likewise, a task that requires the student to use a problem-solving strategy, and is therefore characterized as a mathematical problem, if familiar can be perceived as a known procedural task.

It is difficult to predict what type of task will provoke strategic behavior in terms of self-regulated learning, such as monitoring, using visual aids or consideration of key words. Therefore, only tasks that satisfy the "goal-setting and planning" category, i.e., that provide opportunity for students to choose from several task-solving strategies, will be categorized as potentially promoting strategic competence. Other categories can be considered while observing students in the problem-solving activity. Tasks that satisfy the "goal-setting and planning" are those defined as *open answer* and *open method* tasks. Yeo (2017) in his proposal of the five-dimensional framework for characterizing task openness defines both of these tasks. An open method task refers to multiple methods of solution, and open answer task refers to multiple solutions. In this sense, a task is characterized as open answered if it is not possible to determine all correct answers. An open method task is a task that can be correctly solved by using multiple methods. Yeo (2017, p. 8) considers a task

to be method-closed “if there is only one method or if the method involves only a routine application of known procedures”. Choosing a more proficient procedure in a task with multiple methods is an indication of strategic thinking (Ostler, 2011). Therefore, tasks that have multiple procedural methods will also be considered as promoting strategic competencies, providing that at least one of the procedures is more proficient in the sense of functions. Being presented with a method-open task doesn’t guarantee that students will present strategic competence skills. Yeo (2017) states that students usually use one method that they are familiar with while solving mathematical problems. Further, it is not uncommon for teachers to present only one problem-solving method, therefore denying the opportunity for the development of broader strategic competence skills. Kilpatrick’s et al. (2001) definition of strategic competence implies formulating, representing and solving mathematical problems. Hence, mathematical tasks with context, modelling tasks as well problem posing tasks are considered as promoting strategic competence.

4. Methodology

With the intention of perceiving the aim of the study from more than one standpoint, appointed research questions were answered using triangulation (Cohen, Manion and Morrison, 2009). To address curriculum appointed requirements one of the most commonly used textbooks was analyzed. In order to gain a deeper understanding of students’ adaptive reasoning and strategic competences and identifying phenomena (Cohen et al., 2009) a case study in the form of observations and interviews was conducted.

4.1. Textbook analysis

In this study, a textbook (Dakic and Elezovic, 2015) was analyzed in order to identify tasks which promote adaptive reasoning or strategic competence. In addition to being one of the most commonly used textbooks in the second grade of a general gymnasium, it is the textbook used in the mathematics class of the case study participants. Altogether, 158 tasks from the unit “Second degree polynomial and its graph” were analyzed. Examples (tasks showing all the steps of the solution), and tasks dealing with quadratic inequalities and intersection of a line and parabola were not included in the analysis. Each task was examined to identify the required categories (promoting adaptive reasoning or strategic competence) based on their fitness into instrument (Table 1). Or were otherwise categorized as promoting none of the above. These categories are in accordance with the Kilpatrick et al. (2001) theory of mathematical proficiency, and their dimensions are derived from the analysis of literature regarding adaptive reasoning and strategic competence in mathematics education (Breen and O’Shea 2010, 2018; Kilpatrick et al., 2001; Ostler, 2011; Özdemir and Pape, 2012; Pape and Wang, 2003; Yeo, 2007). Because of the focus on meaning in the context of tasks, for their examination a qualitative approach was needed (Cohen et. al, 2009). For this purpose, a qualitative content analysis method was used (Mayring, 2000).

Table 1. Instrument for textbook analysis.

ADAPTIVE REASONING	
Dimensions	Details and codes
Transfer of knowledge activities	Promoting interpretation of the concept in different representations [ToK1] Generation of example [ToK2]
Representational activities	Generating function equation from verbal description [R]
Analyzing reasoning activities	Requirements to justify correctness or falsity of their own or given reasoning [AR]
Activities of evaluating mathematical statements	Requirements to justify correctness or falsity of a given statement [ES]
Activities of proving, showing or justifying general argument	Requirements to prove, show or justify a general argument [P]
Problem-solving and modeling activities	Tasks requiring problem solving or modeling [M]
Activities promoting inductive reasoning	Requirements to make a conclusion from observation of given pattern, or table of values [IR]
Activities promoting plausible reasoning	Requirements to make a conclusion upon given information to decide a next step, usage of certain property or formula [PR]
STRATEGIC COMPETENCE	
Dimensions	Details and codes
Goal setting and planning activities	Open method tasks [OM] Open answer tasks [OA]
Representational activities	Generating function equation from verbal description [R]
Problem solving and modeling	Tasks requiring problem solving or modeling [M]
Problem generation activities	Requirements to formulate a problem with given characteristics [PG]

4.2. Case study

The case study involved three female students in the second grade of a general gymnasium. The participants were selected based on ability: a high, an average and a low achiever, with the additional criterions of attending the same school and being taught by the same mathematics teacher. The participants had learned and been tested on the topic of quadratic function two months prior to the interview.

Participant A is a high-achieving student in mathematics, who had excellent grades in elementary school and is getting excellent grades in secondary school, including in quadratic function. Participant B is an average-achieving student in mathematics. Although this participant achieved high grades in elementary school, she is struggling somewhat with high school mathematics. She initially failed the test on quadratic function but retook it and passed with a very good grade. Participant C is a low-achieving student in mathematics, with a pass level grade in

secondary education so far. This participant failed the quadratic function test and had not yet retaken the test at the time of the interview. Insight into the participants' mathematical efficiency and grades was gained through conversation with their mathematics teacher.

In this study, qualitative methods of observations and a semi-structured interview have been used. At the beginning of the interview the participants were asked to define (or describe) a function, and to state everything they connect with the notion of quadratic function. The aim of these questions was to get a general understanding of the students' concept formation. The participants were then presented with four tasks (Appendix B) and were observed in their problem solving attempts. All four tasks promote both adaptive reasoning and strategic competence. Task 1 was chosen because of its categorisation as a known and familiar quadratic function task. It was taken directly from the mathematics textbook used by the participants in class. Task 2 is a problem-solving and modelling task. Although the presentation of the task is characterised as unfamiliar to participants, it requires the reading of features from a coordinate system, and is therefore familiar. This task was chosen because of its direct requirement to explain and justify the given answer. It was given in two variations, the first variation is characterised as having higher expectations and was therefore presented only to the high-achieving participant. Task 3 is an example of a generation task. It was chosen because of its characterisation as an unfamiliar task, requiring a high level of adaptive reasoning, and as an open answer task, also promoting strategic competence. Task 4 is a representational activities task that can commonly be found in textbooks, it is given with a minor modification, which is estimated not to have changed the familiarity of the task.

After each task, the interviewer asked the participant some questions regarding their problem-solving strategy and reasoning, and about their usual behaviour when presented with a mathematical task. The topic of the interview was prepared in advance and was guided by the table of indicators of adaptive reasoning and strategic competence (Appendix A). Some questions arose from the observations of the students' problem-solving processes and were also addressed during the interview.

The transcripts of the interviews and the observation notes were analysed using the same method as for the textbook analysis, qualitative content analysis (Mayring, 2000). The students' answers to the interview questions as well as their observed actions as they attempted to solve the problems were coded according to the presence of indicators of adaptive reasoning or strategic competence (Appendix A).

5. Results

The results of textbook analysis and case study investigation are presented in two sections, according to the research questions.

5.1. Results of adaptive reasoning in quadratic function

The textbook analysis showed that 58.22 % of the 158 tasks examined promote adaptive reasoning. The classification of tasks regarding the dimensions of adaptive reasoning are given in Table 2. The majority of tasks promoting adaptive reasoning, 46.76 %, are from the dimension requiring plausible reasoning. These are tasks that require students to make a conclusion upon given information to decide the next step, and the use of a certain property or formula. Only 19.57 % of the tasks from the category of adaptive reasoning promote the transfer of knowledge in terms of promoting interpretation of the concept in different representations. The tasks from dimensions of analyzing reasoning, evaluating statements, promoting inductive reasoning or transfer of knowledge in terms of generating examples, are not represented in the analyzed unit.

Table 2. Requirements in adaptive reasoning in the unit “Second degree polynomial and its graph”.

	TOK 1	TOK 2	R	AR	ES	P	M	IR	PR
frequencies	18	0	15	0	0	3	13	0	43
% in all unit tasks	10.23	0.00	8.52	0.00	0.00	1.70	7.39	0.00	24.43
% in adaptive reasoning category	19.57	0.00	16.30	0.00	0.00	3.26	14.13	0.00	46.74

Legend: ToK1, ToK2: Transfer of knowledge activities; R: representative activities; AR: analysing reasoning activities; ES: activities of evaluating mathematical statements; P: proving of general argument; M: problem solving and modelling; IR: activities promoting inductive reasoning; PR: activities promoting plausible reasoning.

During the observations of the task-solving activity, and in the participants' answers to the questions in the interview, some indicators of adaptive reasoning behaviour were exhibited. It is important to note that neither the given tasks nor the interview questions were constructed in such a way as to stimulate the emergence of dimensions proving, showing or justifying a general argument, justifying the correctness or falsity of a statement or reasoning (other than their own) or inductive reasoning. Consistent indications of the dimensions of adaptive reasoning were observed only in the case of the high-achieving participant. While with the average- and low-achieving participants indicators of a deficiency of adaptive reasoning dimensions emerged. All three participants demonstrated a high level of memorization in problem solving attempts, indicating a lack of adaptive reasoning. The results will be presented according to the dimensions of adaptive reasoning.

5.1.1. Providing explanations and justifications for one's own work

The average- and low-achieving participants demonstrated only intuitive explanations of their work. And this was almost exclusively for Task 2 (Appendix B). Reasoning was indicated by statements such as: “*This is true, because I read it from the graph*”, or by offering an explanation of the choice of procedure: “*I wrote*

the data which is known and the formula for the area of a rectangle. And I tried to solve this and find one unknown”.

The high-achieving participant’s work was reasoned within quadratic function theory, and was not only intuitive. For example: “ a_2 can’t be zero because then I wouldn’t have a second degree polynomial, thus this is [meaning a_1] the only solution”, or “this part [indicating the information about the perimeter of the rectangle in Task 4] should actually be important, because it is a constant part of this function”.

5.1.2. Plausible reasoning

With the average- and low-achieving participants, indicators of plausible reasoning appeared only in the form of the correct interpretation of the context in the graph reading activity. The high-achieving participant demonstrated consistency in this dimension, such as noticing known data or a calculated value and making a conscious decision to use it in a certain way.

The lack of this dimension is related to the situation where a participant is unable to recognise the usefulness of given data. This was indicated with statements such as: “*It seems like there is some data missing in the task*”, “*If the vertex of parabola was given, or for example just picture [indicating the graph of the function], I could solve it*” or with the action of randomly substituting given data with factors of quadratic function formula.

5.1.3. Transfer of knowledge

This dimension was indicated when participants showed signs of interpretation of the concepts in the different function representation. For example, connecting the information “the maximum value is 9” with the formula for the y-coordinate of the vertex of parabola, or with the appearance of the parabola (the opening of the parabola is downward). These indicators were noticeable only in the high-achieving participant. The average and low-achieving participants demonstrated some basic interpretation of the contextually given data in the graph reading activity.

The lack of transfer of knowledge was indicated with statements such as: “*If f is a second degree polynomial with the maximum value of 9, I don’t know how to write this*”. The ability to produce an example of a quadratic function with the given characteristic (Task 3, Appendix B) was not demonstrated by either participant.

5.1.4. Meaningful navigation through many procedures, concepts and solution methods

This dimension was demonstrated only by the high-achieving participant, and it was evident throughout the entire problem-solving process. Indicators of this are continuous contemplation about the concepts given in the task, and all according

properties or formulas, as well as their meaning in different function presentation. This meaningful navigation is especially noticeable in the interaction between the dimension of transfer of knowledge and plausible reasoning.

5.2. Results of strategic competence in quadratic function

The textbook analysis showed that only 46 out of 158 tasks in the unit examined, i.e. 29.11 %, promote strategic competence. The classification of tasks regarding the dimensions of strategic competence are given in Table 3. The most prevalent dimensions of strategic competence are open-method activities, representational activities, and problem-solving and modelling activities, with 36.96 %, 32.61 % and 28.26 % respectively. That is, tasks with the possibility of reaching a solution in a more proficient way, translating verbal information into symbolic (generation of function equation) and problem-solving and modelling tasks, mostly with context. There is only one open-answer task, which requires students to compare graphs of quadratic function, without specifying the requirements of comparison. Tasks from the dimension of problem generation are not represented in the analyzed unit.

Table 3. Requirements in strategic competence in the unit “Second degree polynomial and its graph”.

	OM	OA	R	M	PG
frequencies	17	1	15	13	0
% in all unit tasks	10.76	0.63	9.49	8.23	0.00
% in strategic competence category	36.96	2.17	32.61	28.26	0.00

Legend: OM: open-method task; OA: open-solution task; R: representative activities; M: problem solving and modelling; PG: problem generation activities.

During the observations of the task-solving activity and in the participants' answers to the questions in the interview, some indicators of strategic behaviour were exhibited. Neither the given tasks nor the interview questions were constructed in such a way as to stimulate the emergence of the problem generation dimension. Some indications of the dimensions of organising and transforming, seeking information and goal-setting and planning, were observed in all the participants. However, the presence of keeping records and monitoring and self-evaluating were observed only in the high-achieving participant. The results will be presented according to the dimensions of strategic competence.

5.2.1. Organizing and transforming

Some basic organizing indicators, such as writing down known data or quadratic function formula (unrelated to needing to use it), are indicated in all participants. The high-achieving participant showed indicators of representing a problem symbolically, with a table of values or graph, as well as attempts to clarify and represent a given problem verbally.

5.2.2. Seeking information

With the average- and low-achieving participants the dimension of seeking information was indicated only in terms of re-reading the task. Some deficiencies in seeking information were observable in the form of the inability to independently notice key words or specific task requirements. The high-achieving participant showed behaviour such as searching through key words and connecting them to all known formulas or properties and returning to the task formulation whenever an obstacle was encountered.

5.2.3. Goal setting and planning

A high level of memorization and application of quadratic function formula is involved in the participants' strategic behaviour. This is indicated by statements such as: *"Maybe I don't remember, but I don't think we've done this type of task"*, *"Just a moment, let me remember how this goes"*, or *"Usually I read the task and write down formulas"*. This type of behaviour is exhibited particularly in the average- and low-achieving participants. A consistent strategy in goal setting and planning of quadratic function tasks was noticeable in the high-achieving participant. Although there were some indicators of inventing and adjusting strategies in the task-solving process, the major goal was always the same. The approach to the problem was always algebraic, with the aim of finding three pairs of values and placing them into the general form of a quadratic function formula.

5.2.4. Keeping records and monitoring

Indicators of this dimension are related to rechecking calculations in the process of solving tasks. These actions were indicated by statements such as: *"I have a feeling I did something wrong"*, *"Did I calculate this correctly?"*, or *"This doesn't really make sense"*, followed by checking the work done so far.

5.2.5. Self-evaluation

Indicators of this dimension are related to participants checking the correctness of the final answer or their own work. The checking of the correctness of the answer is indicated by statements such as: *"I hope this is correct"* or *"I think this is good enough"*, signifying that there is no need to continue working on a problem or seeking a more proficient solution. Two phenomena occurred in this dimension. One is a deciding point for checking the correctness of the solution, and the other is reflection on the work. The former is connected to a subjective evaluation of the solution being "nice enough". And the latter indicates the memorization of approaches seen in the mathematics classroom, and remembering them being the only way of considering the possibility of more efficient approaches.

6. Discussion and conclusions

Textbooks are the most frequently used resources in lesson preparation, therefore, their examination could potentially provide a broader and deeper picture of both curriculum requirements and classroom practices (Glasnovic Gracin, 2018). Although analysis of textbooks, as a curriculum requirement and influencer of classroom practice can be considered in relation to the participants' demonstrated skills, it cannot be considered as the only indicator. In this discussion, some connections between the results of the textbook analysis and the adaptive reasoning and strategic competence skills demonstrated have been indicated.

The study of adaptive reasoning and strategic competence in the field of quadratic function has revealed that the analyzed textbook does not provide a high amount of tasks which potentially promote adaptive reasoning or strategic competence. As much as 41.77 % of all the tasks examined do not promote either adaptive reasoning or strategic competence. These are either procedural tasks, or tasks requiring basic levels of conceptual knowledge (e.g. definition, formula) but without the activation of adaptive reasoning skills, or the possibility of activating strategic behaviour. This implies that a large amount of the tasks in the examined textbook are merely procedures or exercises. That is to say, the textbook does not provide satisfactory conditions for the development of quadratic function in terms of adaptive reasoning and strategic competence.

6.1. Discussion on adaptive reasoning

The study revealed that the examined textbook does not provide a full range of task types that could promote adaptive reasoning. Tasks from the dimensions of analyzing reasoning, evaluating statements, promoting inductive reasoning or transfer of knowledge in terms of generating examples, are not represented at all. The most frequent task type is from the dimension of activities promoting plausible reasoning (46.74 %). This is in accordance with the results of the case study, which showed that the most activated indicator with the high-achieving participant is regarding plausible reasoning. This was confirmed even in her explanation of her usual practice when dealing with a problem: "I try to find all the possible variants by looking at what is given in the task". Activation of plausible reasoning was most observed in a situation where the participant wasn't sure of the course of the task-solving process in advance (Task 4). In this situation, plausible reasoning was indicated with the interaction of transfer of knowledge, as the participant presented the given data in a different function representation, and used plausible reasoning to adjust the method used to reach a solution.

The higher rate of the appearance of indicators of transfer of knowledge is in accordance with the textbook analysis, given that this dimension is the second most frequent. However, the case study only showed the activation of basic indicators, such as interpretation of information "maximum value" as vertex of parabola (both in terms of formula and influence on the opening of parabola). None of

the indicators of higher-level transfer of knowledge (such as those stated in Appendix A) were demonstrated. The average-achieving participant demonstrated the ability to reach a conclusion if provided with external intervention, such as the interviewer indicating some key words or using analysis to guide toward some partial conclusions. The inability of participants to reach a conclusion on their own was the most prominent indicator of the lack of adaptive reasoning. Although the average-achieving participant, unlike the low-achieving participant, demonstrated some indicators of adaptive reasoning, it was only with external intervention. Thus, both of these participants demonstrated the same, low level of adaptive reasoning. It can be concluded that in the case of these participants, adaptive reasoning skills regarding quadratic function are not developed.

The high-achieving participant demonstrated the existence of the dimensions of adaptive reasoning at some level. This participant showed signs of trying to make sense, and a high level of plausible reasoning, but her transfer of knowledge was on a basic level and, when in doubt, resorted to intuitive and not concept-based choices and explanations. Thus, although she is characterized as a high-achieving student, it can be concluded that her adaptive reasoning skills regarding quadratic function are average.

6.2. Discussion on strategic competence

The study revealed that the examined textbook does not provide a satisfactory amount of tasks that could promote strategic competence. The results showed that only one task is classified as an open-answer task, and that tasks requiring generation of a problem with given characteristics are not represented at all. The most commonly represented type of tasks promoting strategic competence are open-method tasks (36.96 %). However, in the case study, no diversity of methods was noticed. As stated by Yeo (2017), being presented with a method-open task does not guarantee that a student will present strategic competence skills. Students show a tendency to use the method that they are most familiar with, or is the only method that has been demonstrated in their mathematics lessons. This assertion was confirmed not only with the consistency in the approach (algebraic) to quadratic function tasks, but also in the explanation of why another approach (e.g. graphical) was not used: “*We didn’t really do it [referring to other approaches] in class and, generally, I prefer solving mathematical equations than reading graphs*”.

It can be concluded that the participants’ goal setting and planning skills, as well as skills of organizing and transforming are basic. The results demonstrate that the dimension of organizing and transforming is mostly indicated by writing down given data and attempting to represent a problem symbolically (using function formula). This activity was, with the average- and low- achieving participants, combined with the goal-setting dimension which indicated a high level of memorization. Özdemir and Pape (2012) state that less strategically competent learners demonstrate only the use of basic rehearsal strategies, such as copying, and highlighting, that enable only selecting and acquiring information, but not comprehension. Memorization is considered to be a lower level reasoning skill (Breen and

O'Shea, 2010, p. 39) and therefore an indicator of a lack of strategy. Thus, it can be concluded that the average- and low-achieving participants are strategically less competent.

The high-achieving participant demonstrated a high level of seeking information skills, as well as monitoring of her own work. One of Özdemir and Pape's (2012) 12 categories of strategic behavior is "seeking social assistance", meaning seeking help from a teacher, parents or peers. This dimension was not part of the research instrument because of the postulation of the research for examining the independent work of students. Nevertheless, the average-achieving participant demonstrated a high level of activation of seeking social assistance. This was indicated by frequent pauses during the problem-solving activity, where after writing a formula or conclusion the participant looked at the interviewer seeking confirmation. A further indication came in the form of many questions seeking clarification of the requirements, such as: "What would the dependence of rectangle area of the length of one of its sides mean?"

6.3. Discussion on the connection between adaptive reasoning and strategic competence

Strategic competence is closely connected not only to adaptive reasoning, but also to conceptual understanding and a high level of procedural fluency. Ostler (2011) states that adaptive reasoning and strategic competence are highly interdependent and that those two strands represent different aspects of a more comprehensive kind of mathematic teaching and learning. Students use reasoning to determine the legitimacy of a chosen strategy, or the most strategically appropriate procedure. Also, by practicing strategic competence to choose among effective procedures, students develop procedural fluency (Kilpatrick et al., 2001). The results confirmed the interdependence between adaptive reasoning and strategic competence. All tasks classified as promoting strategic competence are also classified as promoting adaptive reasoning. Which means that as much as 48.91 % of the tasks promote adaptive reasoning. The connection between adaptive reasoning and strategic competence was observed particularly in the case study, where a lack of indicators of a higher level of transfer of knowledge prevented the participants from using more efficient problem-solving strategies, resulting in the use of more complex and time-consuming procedural techniques.

The connection between conceptual reasoning and adaptive reasoning as well as strategic competence was particularly highlighted in this study. Presenting the interdependence between strands of mathematical proficiency, Kilpatrick et al. (2001) state mutually supportive relations between strategic competence conceptual understanding, as the development of strategies for solving non-routine problems depends on understanding involved quantities and their relationships. They also state that for students to understand reasoning or algorithm, they need experience in explaining and justifying them in many different problems, indicating the connection between conceptual knowledge and adaptive reasoning. Also, that one of the conditions for a student to reason adaptively is having a sufficient

knowledge base. This was confirmed by the case study. The participants who demonstrated a lack of basic quadratic function concept formation, in the sense of not knowing what the concept of function is, not being familiar with the quadratic function formula, or some quadratic function (or function in general) properties, were unable to demonstrate any adaptive reasoning other than intuitive explanations and connections based on memorization, while their strategies were dependent exclusively on putting given quantities into formula. If not able to use this strategy, participants demonstrated lacking of any other attempt to solve the given task or drawing the conclusion that some data must be missing. The separation of adaptive reasoning and strategic competence from other strands of mathematical proficiency is considered to be a shortcoming of this study. In his work about mathematical proficiency and means assessment, Burkhardt (2007, p. 79) states: “assess valued components of mathematical proficiency, not just its separate components”. The indicated correlation between strands of mathematical proficiency in this study has confirmed the validity of Burkhardt’s statement.

6.4. Conclusion

To conclude, the study of adaptive reasoning and strategic competence in the field of quadratic function in a Croatian general gymnasium shows that the analyzed textbook does not provide a large number of tasks potentially promoting adaptive reasoning or strategic competence. This implies that a large proportion of the tasks in the textbook are merely procedures or exercises. The study also revealed that the textbook does not provide a full range of task types that could promote adaptive reasoning and demonstrates a serious lack of open-answered tasks as well as activities requiring the generation of a problem with given characteristics. The participants’ skills regarding adaptive reasoning are in accordance with the textbook analysis, with the highest indicators of plausible reasoning. While it can be concluded that the adaptive reasoning skills of the average- and low-achieving participants’ are not developed, the high-achieving participant demonstrated average skills, particularly in terms of the interaction between the dimensions of transfer of knowledge and plausible reasoning. Nevertheless, a high level of memorization, an indicator of a lack of adaptive reasoning, was identified in all three participants. The participants’ strategic competence is in general underdeveloped, relying mostly on memorization and algebraic approaches, which, in the field of quadratic function, could be regarded as being less proficient.

References

- [1] *Australian Curriculum (n.d.)*. Retrieved from <https://www.australiancurriculum.edu.au/f-10-curriculum/mathematics/key-ideas/>.
- [2] BREEN, S., AND O’ SHEA, A. (2010). Mathematical thinking and task design. *Irish Mathematical Society Bulletin*, 66, 39–49.

- [3] BREEN, S., AND O'SHEA, A. (2018). Designing Mathematical Thinking Tasks. *PRIMUS*, 28, 1–12, doi : 10.1080/10511970.2017.1396567.
- [4] BURKHARDT, H. (2007). Mathematical Proficiency: What Is Important? How Can It Be Measured? in A. Burkhardt, H. (2004), in: Schoenfeld, A. (Ed.), *Assessing Mathematical Proficiency*, Cambridge: Cambridge University Press, pp. 77–97.
- [5] COHEN, L., MANION, L., AND MORRISON, K. (2009). *Research methods in education* (6th ed.). London: Routledge.
- [6] DAKIC, B. AND ELEZOVIC, N. (2015). *Matematika 2, udžbenik i zbirka zadataka za 2. razred gimnazija i tehničkih škola, 1. dio*. Zagreb: Element.
- [7] GLASNOVIC GRACIN, D. (2018). Requirements in mathematics textbooks: a five-dimensional analysis of textbook exercises and examples. *International Journal of Mathematical Education in Science and Technology*, 49(7), 1003–1024.
- [8] GROVES, S. (2012). Developing Mathematical Proficiency in the Australian Context. *Journal of Science and Mathematics Education in Southeast Asia*, 35(2), 119–145.
- [9] KILPATRICK, J., SWAFFORD, J. AND FINDELL, B. (2001). *Adding it up*. Washington, D.C.: National Academy Press.
- [10] KILPATRICK, J. (2011). Slouching toward a National Curriculum. *Journal of Mathematics Education at Teachers College*, 2(1), 8–17.
- [11] MAYRING, P. (2000). *Qualitative content analysis*. Retrieved from: <http://www.qualitative-research.net/index.php/fqs/article/view/1089/2385>.
- [12] OSTLER, E. (2011). Teaching Adaptive and Strategic Reasoning through Formula Derivation: Beyond Formal Semiotics. *International Journal of Mathematics Science Education*, 4(2), 16–26.
- [13] ÖZDEMİR, İ. AND PAPE, S. (2012). Supporting students' strategic competence: a case of a sixth-grade mathematics classroom. *Mathematics Education Research Journal*, 24(2), 153–168.
- [14] PAPE, S. J., AND WANG, C. (2003). Middle school children's strategic behavior: Classification and relation to academic achievement and mathematical problem solving. *Instructional Science*, 31, 419–449.
- [15] SCHOENFELD, A. (2007). What is Mathematical Proficiency and How Can it Be Assessed? In: Schoenfeld, A. (Ed.), *Assessing Mathematical Proficiency*, Cambridge: Cambridge University Press, pp. 59–73.
- [16] YEO, J. (2007). *Mathematical Tasks: Clarification, classification and choice of suitable tasks for different types of learning and assessment*. Singapore: National Institute of Education.
- [17] YEO, J. B. W. (2017). Development of a framework to characterize the openness of mathematical tasks. *International Journal of Science and Mathematics Education*, 15, 175–191, doi : 10.1007/s10763-015-9675-9.
- [18] ZIMMERMAN, B. AND MARTINEZ-PONS, M. (1986). Development of a Structured Interview for Assessing Student Use of Self-Regulated Learning Strategies. *American Educational Research Journal*, 23, 614–628.

Appendix A.

Indicators of adaptive reasoning and strategic competence

INDICATORS OF ADAPTIVE REASONING	INDICATORS OF STRATEGIC COMPETENCE
<p>Reflection on own's work:</p> <ul style="list-style-type: none"> ● providing intuitive explanations and justifications of one's own work: <ul style="list-style-type: none"> ○ reasoning or reached conclusion; ○ the legitimacy of chosen strategy; ○ chosen procedure; ● comparing and contrasting related ideas <p>Reflection on given problem and ideas:</p> <ul style="list-style-type: none"> ● showing, justifying or proving general argument; ● proving or justifying correctness/falsity of a given statement; ● proving or justifying correctness/falsity of given reasoning <p>Transfer of knowledge:</p> <ul style="list-style-type: none"> ● interpreting a function throughout different representations; ● producing examples; <p>Inductive reasoning</p> <ul style="list-style-type: none"> ● making conclusions from observation of a given pattern, or table of values <p>Plausible reasoning</p> <ul style="list-style-type: none"> ● making conclusions upon given information to decide a next step, usage of certain property or formula <p>Meaningful navigation through many procedures, concepts and solution methods</p>	<p>Self-evaluating:</p> <ul style="list-style-type: none"> ● self-initiated checking of the quality and correctness of one's own work; ● checking the answers; ● redoing the problems; ● reviewing taken steps <p>Organizing and transforming</p> <ul style="list-style-type: none"> ● organization and representation of a given problem with the aim of: <ul style="list-style-type: none"> ○ achieving (or reaching deeper) understanding; ○ facilitation of a given problem; ● representing a problem numerically, symbolically, verbally or graphically; ● using manipulative materials or visual aids for understanding; ● formation of a mental model; ● breaking down the model (writing down the steps) <p>Goal-setting and planning</p> <ul style="list-style-type: none"> ● the planning of the problem-solving process; ● conscious choosing appropriate, more efficient, or cognitively complex strategy <p>Seeking information</p> <ul style="list-style-type: none"> ● searching for further task information that could be useful in problem solving; ● an indication of key words; ● returning to the problem <p>Keeping records and monitoring</p> <ul style="list-style-type: none"> ● regulating one's work; ● showing and labeling each step (work and solutions recorded); ● rechecking calculation. <p>Formulation of mathematical problems</p>

Appendix B.

Case study tasks with proposed indicators of higher-level adaptive reasoning and strategic competence

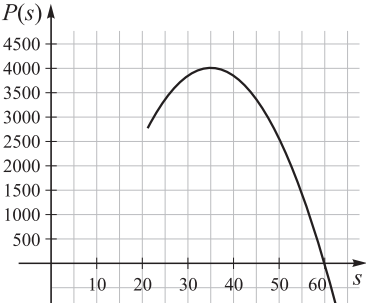
TASK	CODE	INDICATORS OF ADAPTIVE REASONING	INDICATORS OF STRATEGIC COMPETENCE
<p>TASK 1 (Dakic and Elezovic, 2015, p. 80) Determine a second degree polynomial f with maximum value 9 and $f(2) = f(0) = 8$.</p>	[TOK1] [OM]	<ul style="list-style-type: none"> • interpretation of “maximum value 9” as y coordinate of the vertex of the parabola; • from $f(2) = f(0) = 8$ activation of symmetric property of quadratic function; conclusion: x coordinate of the vertex of parabola equals 1; • using properties to justify chosen reasoning/procedure 	<ul style="list-style-type: none"> • representing problem graphically or with the mental model (both include symmetric property of quadratic function); • using more efficient strategy for determination of polynomial: choosing equation of quadratic function in vertex form
<p>TASK 2 [VARIATION 1] It is known that a profit is a quadratic function of a selling price. Part of the graph of the profit function $P(s)$ is given.</p> <p>Determine:</p> <ol style="list-style-type: none"> the selling price for which the maximum profit is achieved. the profit achieved for selling price of $s = 20$ €. the selling price for which there will be no profit. <p>REMARK: explain and justify given answers.</p> 	[M]	<ul style="list-style-type: none"> • transfer contextually given data (e.g. selling price and profit) to the graph of quadratic function (arguments and function value); • use plausible reasoning for graph reading activity; • apply knowledge about symmetric property to predict the behavior of missing part of the graph; • justify answers using the function definition and function (or quadratic function) properties 	<ul style="list-style-type: none"> • use given context to facilitate graph reading activity; • search for indication of key words; • a strategy based on quadratic function graph, not a general interpretation of a graph

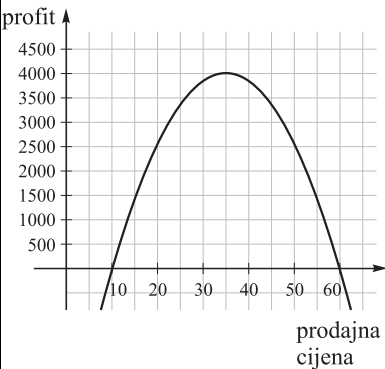
<p>TASK 2 [VARIATION 2] The graph representing how the profit depends on the selling price of the product is given. Determine: a) the selling price for which the maximum profit is achieved. b) the selling price for which the company will be at a loss. c) the selling price for which the profit will be equal.</p> <p>REMARK: explain and justify given answers.</p> 	<p>[M]</p>	<ul style="list-style-type: none"> • transfer contextually given data (e.g. selling price and profit) to the graph of quadratic function (arguments and function value); • use plausible reasoning for graph reading activity; • apply knowledge about symmetric property to answer (and justify) selling prices with equal profit; • justify answers using the definition and properties of functions 	<ul style="list-style-type: none"> • use given context to facilitate graph reading activity; • search for indication of key words; • a strategy based on quadratic function graph, not a general interpretation of a graph
<p>TASK 3 State an example of quadratic function with minimal value 3.</p>	<p>[TOK2] [OA]</p>	<ul style="list-style-type: none"> • using conceptually based plausible reasoning to determine sufficient condition to state example of quadratic function with required characteristics; • justify reached conclusion and choice of strategy using arguments based on the concept of quadratic function 	<ul style="list-style-type: none"> • a strategy based on conceptual knowledge and good time management (no calculations) e.g. $f(x) = x^2 + 3$, or $f(x) = a(x - x_0)^2 + 3$ (a and x_0 replaced with arbitrary real numbers)
<p>TASK 4 Determine a function representing how the area of a rectangle depends on the length of one of its sides if the perimeter of a rectangle is 12 cm.</p>	<p>[R]</p>	<ul style="list-style-type: none"> • reason about the functional relationship of the area of a rectangle and the length of its sides; • transfer knowledge from geometrical concepts to functional relationships 	<ul style="list-style-type: none"> • strategy directed from thinking about geometrical concept to the meaning of functional dependency; • inventing and adapting strategies, shifting approaches if

Contact address:

Matea Gusić
Faculty of Teacher Education
University of Zagreb
Savska cesta 77, Zagreb, Croatia
e-mail: matea.gusic@ufzg.hr

Istraživanje prilagodljivog rasuđivanja i strateških kompetencija u hrvatskom matematičkom obrazovanju: Primjer kvadratne funkcije

Matea Gusić

Učiteljski fakultet, Sveučilište u Zagrebu, Zagreb, Hrvatska

Sažetak. Od osamdesetih godina 20. stoljeća ističe se da brzo i točno izvođenje procedura te reprodukcija velikih količina podataka, nisu dovoljni za razvoj matematički kompetentnog učenika. Naglasak se prebacuje na razvoj rasuđivanja, vještine rješavanja matematičkih problema te sposobnost povezivanja i komuniciranja matematičkih ideja. Primjer teoretskog okvira koji razmatra cjeloviti pristup nastavi matematike, naziva "matematičke kompetencije" (*Mathematical proficiency*), ponudili su Kilpatrick, Swafford i Findell. Navedeni okvir predlaže pet jednako važnih i međusobno povezanih dimenzija. Ovaj rad prikazuje istraživanje dviju dimenzija okvira, prilagodljivo rasuđivanje i strateške kompetencije u učenju i poučavanju sadržaja iz kvadratnih funkcija u Republici Hrvatskoj. Cilj istraživanja je dobivanje predodžbe u indikatore i razvijenost vještina prilagodljivo rasuđivanja i strateških kompetencija. Analizom jednog od najzastupljenijih matematičkih udžbenika za opće gimnazije dobiven je uvid u kurikularne zahtjeve u vidu opsega i vrste zadataka koji potencijalno promoviraju istraživane dimenzije. Studija slučaja, u kojoj su sudjelovale tri učenice drugog razreda opće gimnazijskog programa, omogućila je uvid u aktivaciju vještina prilagodljivog rasuđivanja i strateških kompetencija prilikom rješavanja zadatka iz kvadratne funkcije.

Cljučne riječi: matematičke kompetencije, prilagodljivo rasuđivanje, strateške kompetencije, kvadratna funkcija, analiza udžbenika, studija slučaja

Treatment of initial multiplication in textbooks from Croatia and Singapore

Tihana Baković¹, Goran Trupčević*¹ and Anđa Valent²

¹ Faculty of Teacher Education, University of Zagreb, Croatia

² Zagreb University of Applied Sciences, Croatia

Abstract. In this paper, we aim to partially characterize the way of teaching mathematics, specifically the initial learning of multiplication in the Croatian education system.

Because teaching is a socio-cultural phenomenon, in describing it, it is necessary to step out of the cultural frame, since only then one can notice some of its attributes that from the inside appear to be self-evident.

For this reason, we compared the treatment of initial multiplication learning, including the multiplications table, in textbooks from Croatia and Singapore. In the analysis of the textbooks we used an adapted framework from Charalambous, Delaney, Hsu and Mesa (2010) that looks at a textbook as an environment for construction of knowledge of a single mathematical concept.

Keywords: mathematics textbooks, analysis of concept construction, initial multiplication

1. Research question

One of the main findings of TIMSS video analysis of classroom teaching in Japan, Germany and the United States was that teaching is a cultural activity (Stiegler and Hiebert, 1999). Although teaching methods among teachers from one country may vary, these variations are far less than those between teaching methods from one country to another. Hence one can speak of a cultural code of teaching that is passing through generations of teachers of one teaching tradition. A confirmation for this can be found in the introductory part of the Croatian mathematics curriculum (MZOŠ, 2006, p. 238): “In the existing elementary school, mathematics is a

*Corresponding author.

subject with long-lasting tradition and well-defined content, and no major interventions are required in current programs. Therefore, the existing programs formed the starting basis in the design of the mathematics curriculum.”

Since 2014 Croatian educational system is going through a process of curricular reform. The first drafts of new curriculums were released in 2016, which was followed by the expert discussion. One of the frequent complaints concerned learning of the multiplications table. The original proposal has predicted that the multiplications table should be taught in the 2nd grade, but its automation should be postponed to the 3rd grade. A large number of primary education teachers have asked for this learning outcome to be returned to the 2nd grade, which was ultimately accepted.

This large number of complaints lead us to believe that learning multiplications table presents one of those deeply engraved practices of Croatian mathematics teaching tradition. Therefore, it would be interesting to inspect this practice more closely.

Because of the cultural determinacy of teaching one needs to step out of a teaching tradition in order to study it. International comparative analyses are one way of making this stepping out. In the present study our goal is to examine Croatian tradition of teaching initial multiplication and we do this by comparing Croatian and Singapore textbooks. Within the TIMSS Mathematical Framework (Valverde et al., 2002) textbooks are conceived as part of the potentially implemented curriculum – they are mediators between what is supposed to happen and what actually happens inside classrooms. Numerous studies, both in Croatia and in other countries, have confirmed great impact textbooks have on the actual teaching (Pepin & Haggarty, 2001; Haggarty & Pepin, 2002; Fan & Kaeley, 2000; Glasnović Gracin & Domović, 2009; Domović, Glasnović Gracin & Jurčec, 2012; Glasnović Gracin & Jukić Matić, 2016). For this reason, we believe that through comparing Croatian and Singapore textbooks we will be able to describe important features of Croatian tradition of teaching initial multiplication.

We have chosen Singapore textbooks as a standard upon which we reason about Croatian textbooks and Croatian mathematics education because:

- Croatia and Singapore are far apart geographically,
- Croatia and Singapore are far apart judged by the results on international comparative studies,
- Singapore education system is changing more often than the Croatian education system, which hasn't changed much during the last 30 years,
- Singapore mathematics teaching is well known for some of its distinct features like concrete-pictorial-abstract approach, Singapore bar model method, etc.
- availability of Singapore textbooks.

2. Croatian and Singapore Mathematics Curriculum

Current Croatian national curriculum mathematics was published in 2006 and it is supposed to be replaced with the new one in the process of curricular reform.

It is divided into two parts: the introductory part and the list of themes for each year of study, together with students learning achievements. In the introductory part the curriculum states that the main objective of mathematics teaching is

“the acquisition of basic mathematical knowledge needed to understand phenomena and laws in nature and society, acquisition of basic mathematical literacy and development of abilities and skills of mathematical problem solving” (MZOŠ, 2006, p. 238).

This is further divided into the following student expectations:

- “learn to mathematically express themselves in writing and orally,
- develop skills of writing, reading, and comparing numbers,
- knowing how to apply the acquired mathematical knowledge in everyday life,
- develop abilities and skills of (solving) basic mathematical problems needed for further education,
- recognize mathematics as a useful and necessary part of science, technology and culture,
- develop abilities of abstract and logical thinking and precise formulation of terms,
- develop a sense of responsibility and critics towards his work and work of others,
- develop ability to work independently, responsibility for work, accuracy, neatness, systematicity, precision and conciseness in writing and oral expression” (MZOŠ, 2006, p. 238).

The curriculum also “highlights the application of math at which it should be looked at as a practical, useful subject that students need to understand and that can be applied to various problems in their environment” (MZOŠ, 2006, p. 238).

Themes of beginning multiplication are placed in the second grade, after addition and subtraction of numbers up to 100. It starts with multiplication and commutativity law for which it is expected from students “to understand multiplication as addition of equal addends, to use mathematical notation for multiplication” and “to understand and apply commutativity law for multiplication” (MZOŠ, 2006, p. 240). This is followed by multiplication tables of 2, 5, 3 and 4, multiplication by 1 and 0, and multiplication tables of 10, 6, 7, 8 and 9 and the corresponding learning achievements are to master procedures of multiplication by these numbers (MZOŠ, 2006). It ends with the theme of the multiplication table. Division is introduced after multiplication by 2 and 5 and from that point on multiplication and division themes are intertwined.

Current Singapore Mathematics Syllabus (MOE, 2012) started its implementation in 2013. It is much more elaborated than the Croatian curriculum.

The main goal of the Singapore mathematics syllabus is “to ensure that all students will achieve a level of mastery of mathematics that will serve them well in life, and for those who have interest and ability, to pursue mathematics at the highest possible level” (MOE, 2012, p. 7).

Mathematics framework of the Singapore mathematics syllabus places mathematical problem solving in the central place, from which other five major components emerge: mathematical concepts and skills, mathematical processes and metacognition, and attitudes towards mathematics.

Syllabus also gives guidance on learning experiences, principles of teaching and phases of learning and on assessment that supports teaching and learning. As it is established in the mathematical framework, learning mathematics is not just learning concepts and skills, but also developing attitudes, thinking processes and metacognitive skills. Therefore, it is important for students to be given proper experiences that will help them in that. Later in the syllabus for each topic it is given the list of corresponding learning experiences. Besides these topic-specific experiences, curriculum also lists some generic ones: “taking notes and organizing information; practicing mathematical skills; using feedback from assessment to improve learning; solving novel problems using a repertoire of heuristics; discussing articulating and explaining ideas to develop reasoning skills; and carrying out a modelling project” (MOE, 2012, p. 20).

As the guiding principles of teaching curriculum emphasizes subordination of teaching to learning and learning to problem solving; student-centered approach which engages students in active and reflective learning; and the usage of ICT skills. Curriculum envisages three phases of learning (and instruction): readiness, engagement and mastery. Readiness phase considers student’s prior knowledge, motivating contexts and a learning environment that promotes interactions between students and teacher and among students, and has established procedures for organizing students and managing resources. The engagement phase is organized around three pedagogical approaches: activity-based learning, teacher-directed inquiry and direct instruction. These three approaches are not mutually exclusive and could all be used within a single lesson. Mastery is the final phase in which students learning is consolidated and extended. It includes: motivated practicing, reflective review and extended learning.

The syllabus also emphasizes the integration of assessment with teaching and learning. Therefore, it gives primacy to formative and diagnostic assessment instead of summative assessment, and it lists the following strategies as examples: questioning, mathematical discussions, providing timely feedback, self-assessment, using rubrics...

In the last part of the syllabus a list of themes for each year is given, accompanied by the appropriate learning experiences. The learning of multiplication starts in the first year with the introduction of the concept of multiplication and the symbol “ \times ”, multiplying within 40 and solving simple word problems with pictorial

representation. This should be acquired through learning experiences of making equal groups using concrete objects and counting the total number by repeated addition and using language such as ‘2 groups of 5’ and ‘2 fives’. Along with multiplication the concept of division is also introduced, and multiplication topics are usually followed by division topics in the first year and the years to follow.

In the second year students learn multiplication tables of 2, 3, 4, 5 and 10, relationship between multiplication and division, multiply within the multiplication tables solve simple word problems and mentally calculate within the multiplication tables. This should be achieved through making multiplication stories by working in groups and writing appropriate multiplication equation and creating word problems for other groups to solve; through using concrete objects and pictorial representations to illustrate the concept of multiplication; by exploring number patterns in the multiplication tables through activities such as coloring the hundred chart; and solving non-routine problems by using heuristics such as ‘act it out’ and ‘draw a diagram’ and sharing ideas with their peers. Mastery of multiplication facts is achieved through using multiplication fact-cards and through playing games, including applets and digital games.

In the third year this is extended to multiplication tables of 6, 7, 8 and 9. In this grade students should also learn to solve 2-step word problems involving all 4 operations.

3. Methodology

After comparing the content of both curricula, we found that the multiplication table in Croatian schools is studied in the second grade, and in Singapore from the first to the third grade.

In this preliminary study we have included one series of Croatian textbooks (CT) and one series of Singapore textbooks (ST). These are:

1. MIKLEC, D., PRTAJIN, G., & JAKOVLJEVIĆ ROGIĆ, S. (2015). *Moj sretni broj 2*. Zagreb: Školska knjiga.
2. FOONG, P.Y., CHANG S.H., LIM L.G.P., & WONG O.H. (2017). *Primary mathematics 1B*. Singapore: Shinglee.
FOONG, P.Y., LIM L.G.P., & WONG O.H. (2017). *Primary mathematics 2A*. Singapore: Shinglee.
FOONG, P.Y., CHANG S.H., LIM L.G.P., & WONG O.H. (2017). *Primary mathematics 3A*. Singapore: Shinglee.

In the analysis of textbooks we used an adapted framework from Charalambous, Delaney, Hsu and Mesa (2010). In our analysis we have included all lessons concerning multiplication upon the multiplications table. Each lesson is divided into smaller segments – blocks, and each block has been analyzed through several categories – *block type, social form of work, context, use of concrete materials, images, representations, construct and multiplication strategies*.

The first category – *block type* refers to the form used to address students – that is, whether it is a solved example, an exercise, an activity...

Social form of work category refers to a social context in which students work – whether it is individual work, work in pairs or in groups. We have only categorized those blocks where the social context was clear, while other blocks were labeled "unclear".

In the *context* category, we are assessing whether the content of the task is related to a non-mathematical context or if it is exclusively intra-mathematical content. Non-mathematical context can be realistic – connected with a real-life problem, or authentic – related to student's personal experience or their environment.

Use of concrete materials category refers to the use of manipulative materials and, if so, which ones (e.g. Unifix cubes, chips, ...).

Visual features of blocks were assessed through two categories – *images* and *representations*. *Images* identifies whether there is an image present, and, if there is one, is it mathematically relevant to the block content. *Representations* classifies the ways in which the multiplication is represented, whether through an image, or a table, or some action. These include: set representation (image of objects grouped into sets), linear representation (objects grouped in an array), number line, area representation (objects grouped into rows and columns), counting, multiplications table and bar model representation.

Construct refers to the way that the meaning of multiplication is constructed – equal groups (3 groups, each containing 4 objects, is a total of 3 times 4 objects), repeated addition (3 times 4 equals $4 + 4 + 4$), area (arrangement of 3 rows and 4 columns), scaling (including multiplicative comparison – 12 is 3 times bigger than 4), number line (3 times 4 means move 3 times by 4 units), counting (4, 8, 12), combinatorial (4 different objects of one kind can be combined with 3 different objects of another kind in 12 different ways).

The last category, *multiplication strategy*, refers to a use of some strategies to carry out a multiplication. This includes the use of properties of multiplication (e.g. commutativity, distributivity), use of counting, multiplications table, addition/subtraction of one more (computations such as $9 \cdot 5 = 10 \cdot 5 - 5$), and doubling/halving strategy (computations such as $4 \cdot 8$ is twice more than $2 \cdot 8$, which is equal to $16 + 16$).

4. Results

4.1. Textbook structure comparison

Singapore textbooks are divided into chapters that are further divided into lessons. At the beginning of each chapter there is a chapter opener – a motivational exercise that introduces students to the chapter. The first lesson in the chapter starts with a recap exercise that is always accompanied by a mathematically relevant image

and representation. All lessons are further structured in the same way: a lesson begins with a motivational task that introduces questions that will be further considered within the lesson. New concepts are introduced through three to four solved examples.

IN FOCUS



What is the total number of frogs?

LET'S LEARN

1. 1 tank has 6 frogs.



1 group of 6
 $1 \times 6 = 6$







2 groups of 6
 $2 \times 6 = 12$

are 12 frogs altogether.

2.

Make groups of 6 using .

	$1 \times 6 = 6$
	$2 \times 6 = 12$
	$3 \times 6 = 18$
	$4 \times 6 = 24$
	$5 \times 6 = 30$
	$6 \times 6 = 36$
	$7 \times 6 = 42$
	$8 \times 6 = 48$
	$9 \times 6 = 54$
	$10 \times 6 = 60$

MULTIPLICATION AND DIVISION 60

3. Count in sixes.



6, 12, 18, 24, 30, 36, 42, 48, 54, 60

4.



$7 \times 6 = ?$

$5 \times 6 = 30$
 $7 \times 6 = 30 + 12$
 $= 42$

$2 \times 6 = 12$

5.



$2 \times 6 = \square$

$10 \times 6 = 60$
 $8 \times 6 = 60 - \square$
 $= \square$

61 CHAPTER 3

PRACTICE

1. A flower has 6 petals.



$6 \times \square = \square$

8 flowers have petals altogether.

2. Complete the multiplication table.

$1 \times 6 = \square$	$6 \times 6 = \square$
$2 \times 6 = \square$	$7 \times 6 = \square$
$3 \times 6 = \square$	$8 \times 6 = \square$
$4 \times 6 = \square$	$9 \times 6 = \square$
$5 \times 6 = \square$	$10 \times 6 = \square$

3. What are the missing numbers?
6, 12, , 24, 30, 36, , 48, , 60

Complete Worksheet 1A Page: 53-56

MULTIPLICATION AND DIVISION 62

63 CHAPTER 3

Figure 1. Lesson from Singapore textbook: Multiplication table of 6.

The first example is completely solved and in each of the following examples the level of details is gradually diminishing. All examples are realistic, accompanied by mathematically relevant images and there is a clear multiplication construct. In lessons on multiplication table of a certain number, there is a clear pattern in sequencing of blocks – lesson starts with a realistic example, followed by activities of (re)constructing multiplication table with the help of some manipulatives and skip-counting. For multiplication by numbers 6, 7, 8 and 9, there are also examples of using distributive property for multiplication. Some lessons contain activities that are carried out in pairs or groups and which students perform with manipulatives. A lesson ends with two to four exercises, of which only the last one or two tasks is possibly without an image present and with intra-mathematical context.

Every chapter ends with a non-routine question requiring higher cognitive processes, math journal and a self-assessment block which is in line with the curriculum guideline that formative assessment should be integrated into learning process.

Croatian textbook is divided into lessons. Each lesson spans over two pages. The first page starts with one or two repetition exercises that are not accompanied by an image and the context is intra-mathematical. This is followed by a fully solved example. The example is realistic, accompanied by a mathematically relevant image and there are usually two or three representations and constructs. After the solved example, there is usually a block containing a multiplication table.

MNOŽENJE BROJA 6

ZNAM

Dopuni: $6 \cdot \square = 18$, $\square \cdot \square = 48$, $\square \cdot 60$

Pomnoži: $2 \cdot 6 = \square$, $6 \cdot 1 = \square$, $5 \cdot 0 = \square$
 $6 \cdot 3 = \square$, $4 \cdot 6 = \square$, $3 \cdot 8 = \square$

Koliko je stabala u cvatu?
 $6 + 6 + 6 + 6 = 24$

Vidim 6 stabla u 4 reda.
 $6 \cdot 6 = 36$

U cvatu su 24 stabla.
 $6 + 6 + 6 + 6 = 24$, $4 \cdot 6 = 24$

PRVI FAKTOR	1	2	3	4	5	6	7	8	9	10
DRUGI FAKTOR	6	6	6	6	6	6	6	6	6	6
UMNOŽAK	6	12	18	24	30	36	42	48	54	60

1. Napiši jednakosti zbrajanja i množenja.
 $\square + \square + \square = \square$, $\square + \square + \square + \square + \square = \square$
 $\square \cdot \square = \square$, $\square \cdot \square = \square$

2. Izračunaj.
 $6 \cdot 4 = \square$, $1 \cdot 6 = \square$, $\square = 6 \cdot 6$, $\square = 6 \cdot 2$
 $5 \cdot 6 = \square$, $8 \cdot 6 = \square$, $\square = 10 \cdot 6$, $\square = 9 \cdot 6$
 $6 \cdot 3 = \square$, $6 \cdot 9 = \square$, $\square = 7 \cdot 6$, $\square = 6 \cdot 8$

3. Napiši jednakost množenja sa zadanim faktorima, zatim zamijeni mjesta faktorima i ponovno pomnoži.
 $1 \cdot 6 = \square$, $4 \cdot 6 = \square$, $9 \cdot 6 = \square$, $6 \cdot 8 = \square$
 $\square \cdot \square = \square$, $\square \cdot \square = \square$, $\square \cdot \square = \square$, $\square \cdot \square = \square$
 $\square \cdot \square = \square$, $\square \cdot \square = \square$, $\square \cdot \square = \square$, $\square \cdot \square = \square$

4. Faktori su 6 i 5. Izračunaj umnožak. Dobiiveni umnožak uvečaj za 6.
 RAČUN: _____ RAČUN: _____

5. Napiši brojeve u obliku umnoška, tako da je jedan faktor 6.
 $6 \rightarrow \square$, $12 \rightarrow \square$, $18 \rightarrow \square$
 $24 \rightarrow \square$, $30 \rightarrow \square$, $36 \rightarrow \square$
 $42 \rightarrow \square$, $54 \rightarrow \square$, $60 \rightarrow \square$

Figure 2. Lesson from Croatian textbook: Multiplication table of 6.

The second page of a lesson consists of exercises, usually five or six. In a typical lesson, only the first exercise, and sometimes also the last one (word problem),

has a realistic context. Majority of exercises have an intra-mathematical context. The number of exercises with realistic context reduces from the beginning towards the end of the textbook. Representations and constructs are usually indicated only for the first one or two exercises.

4.2. Images and representations

In ST 82 % of blocks has images that are mathematically relevant. This is in line with the emphasis that Singapore mathematics syllabus puts on pictorial representations. Among these, set representations are present in 38 % of blocks, area representations in 30 % and linear representations in 21 % of blocks. There are no blocks with number line representations of multiplication – this is because the number line is introduced later in the Singapore mathematics syllabus. Besides pictorial representations there are also some non-pictorial representations present – multiplication tables in 14 %, counting in 8 % and a 100-chart in 2 % of blocks. There are also 2 % of blocks in which the Singapore bar model for multiplication was introduced in solving word problems. The 100-chart corresponds to the requirement of the syllabus for opportunities in which students find patterns in multiplication tables, while the bar model facilitates usage of diagrams in solving non-routine problems.

In CT 26 % of blocks has mathematically relevant images. These are equally distributed between number line representations (13 %), set representations (12 %) and area representations (11 %). In 2 % of blocks there are also linear representations present. Such small numbers shouldn't surprise because the Croatian curriculum doesn't mention use of pictures in the process of learning. Of non-pictorial representations there is only multiplications table which occurs in 12 % of blocks.

4.3. Constructs

In ST construct is evident in almost all the blocks – 109 out of 132 blocks (83 %). Although in some blocks multiple constructs are present, in most of the cases a single block often has only one construct. On the other hand, in CT construct is evident a lot less i.e. in a total of 42 out of 107 blocks (39 %). While the solved example in the first part of a lesson refers to several constructs, later exercises often have no evident constructs.

The dominant construct in ST is equal groups which is present in 67 % of blocks, followed by area (13 %), repetitive addition (7 %), counting (7 %) and scaling (5 %). The most common construct in CT is repetitive addition (29 %), followed by equal groups (16 %), number line (13 %) and area (9 %), while scaling and counting appear in only few blocks.

4.4. Multiplication strategies

Singapore textbooks display a whole range of different multiplication strategies – counting appears in 10 % of blocks, commutativity in 8 %, adding/subtracting one more in 5 %, distributivity in 5 % and multiplication by 1 in 1 % of blocks. Multiplication tables appear in 14 % of blocks and memorization techniques appear in 2 % of blocks. In total, 30 % of blocks promote some kind of multiplication strategy. This corresponds to topics of ‘multiplying within multiplications table’ and ‘mental calculations’ in Singapore mathematics syllabus. Modelling by a bar model, which is more of a problem solving than a multiplication strategy, appeared in 2 % of blocks.

In CT commutativity is promoted in 17 % and multiplication by 1 and 0 in 7 % of blocks. Multiplication tables appear in 14 % of blocks and memorization techniques appear in 2 % of blocks. Counting appears in 7 % of blocks, but in a different way than in ST. While in ST there are activities which link skip counting explicitly to multiplication, in CT counting appears in introductory activities of the kind ‘Fill in the missing numbers: 0, 5, 10, –, –, 25,...’.

4.5. Social forms of work and use of concrete materials

In CT the expected social form of work is individual for 75 % of blocks, and for the other 25 % the social form of work is unclear. This ratio corresponds to a big number of exercises compared to a small number of solved examples. Work in pairs or groups is not promoted in any block neither was the use of concrete materials.

In ST there is more solved examples and less exercises within a lesson, hence the social form of work is unclear for 57 % of blocks and for the remaining blocks, 38 % refers to individual work and 5 % to work in pairs or in groups. Use of concrete materials is promoted in 17 % of blocks. This corresponds to the attention that Singapore syllabus places on activity-based learning during the engagement phase, implying that students should have opportunities to explore and learn mathematical concepts by working with concrete materials, individually or in groups.

5. Conclusion

The analysis shows that in Croatia initial learning of multiplication relies on practice to a great extent. Students do not have support in underlying constructs or representations, nor are they encouraged to develop different strategies of computing. Although the multiplications table as a representation is equally present in Singapore and Croatian textbooks, for the above reasons it is expected that Croatian students will use it more frequently as something that should be memorized.

In our further research, we intend to include in the analysis one more series of Croatian and Singapore textbooks and to also include the accompanying workbooks. We believe that in this way we will get a more complete picture of teaching of initial multiplication in Croatia.

References

- [1] CARPENTER, T. P., FENNEMA, E., LOEF FRANKE, M., LEVI, L. & EMPSON, S. B. (2015). *Children's Mathematics, Cognitively Guided Instruction*. Portsmouth, NH: Heinemann.
- [2] CHARALAMBOUS, C. Y., DELANEY, S., HSU, H.-Y., & MESA, V. (2010). A Comparative analysis of the addition and subtraction of fractions in textbooks from three countries. *Mathematical Thinking and Learning, 12*(2), 117–151.
- [3] DOMOVIĆ, V., GLASNOVIĆ GRACIN D., & JURČEC, L. (2012). Uporaba matematičkih udžbenika s obzirom na inicijalno obrazovanje učitelja. *Sociologija i Prostor, 193*(2), 237–256.
- [4] FAN, L., & KAELEY, G. S. (2000). The influence of textbooks on teaching strategies: An empirical study. *Mid-Western Educational Researcher, 13*(4), 2–9.
- [5] FOONG, P.Y., CHANG S.H., LIM L.G.P., & WONG O.H. (2017). *Primary mathematics 1B*. Singapore: Shinglee.
- [6] FOONG, P.Y., LIM L.G.P., & WONG O.H. (2017). *Primary mathematics 2A*. Singapore: Shinglee.
- [7] FOONG, P.Y., CHANG S.H., LIM L.G.P., & WONG O.H. (2017). *Primary mathematics 3A*. Singapore: Shinglee.
- [8] GLASNOVIĆ GRACIN, D., & DOMOVIĆ, V. (2009). Upotreba matematičkih udžbenika u nastavi viših razreda osnovne škole. *Odgovorne znanosti, 18*(2), 45–65.
- [9] GLASNOVIĆ GRACIN, D., & JUKIĆ MATIĆ, LJ. (2016). The Role of Mathematics Textbooks in Lower Secondary Education in Croatia: An Empirical Study. *The Mathematics Educator, 16*(2), 31–58.
- [10] HAGGARTY, L., & PEPIN, B. (2002). An Investigation of Mathematics Textbooks and Their Use in English, French and German Classrooms: Who Gets an Opportunity to Learn What? *British Educational Research Journal, 28*(4), 567–590.
- [11] MIKLEC, D., PRATAJIN, G., & JAKOVLJEVIĆ ROGIĆ, S. (2015). *Moj sretni broj 2*. Zagreb: Školska knjiga.
- [12] Ministarstvo znanosti obrazovanja i športa (2006). *Nastavni plan i program za osnovnu školu*. Zagreb: MZOŠ.
- [13] Ministry of Education Singapore (2012). *Mathematics Syllabus: Primary one to Six*. Singapore: MOE.
- [14] PEPIN, B., & HAGGARTY, L. (2001). Mathematics textbooks and their use in English, French and German classrooms: A way to understand teaching and learning cultures. *ZDM: The International Journal on Mathematics Education, 33*(5), 158–175.
- [15] STIEGLER, J. & HIEBERT, J. (1999). *The teaching gap: Best Ideas from the World's Teachers for Improving Education in the Classroom*. New York: The Free Press.
- [16] VALVERDE, G. A., BIANCHI, L. J., WOLFE, R. G., SCHMIDT, W. H., & HOUANG, R. T. (2002). *According to the book: Using TIMSS to investigate the translation of policy into practice through the world of textbooks*. Dordrecht: Kluwer.

Contact addresses:

Tihana Baković
Faculty of Teacher Education, University of Zagreb
Trg Matice Hrvatske 12, 44500 Petrinja, Hrvatska
e-mail: tihana1310@gmail.com

Goran Trupčević
Faculty of Teacher Education, University of Zagreb
Trg Matice Hrvatske 12, 44500 Petrinja, Hrvatska
e-mail: goran.trupcevic@ufzg.hr

Anđa Valent
Zagreb University of Applied Sciences
Konavoska 2, 10000 Zagreb, Hrvatska
e-mail: avalent@tvz.hr

Obrada početnog množenja u udžbenicima iz Hrvatske i Singapura

Tihana Baković¹, Goran Trupčević¹ i Anđa Valent²

¹ Učiteljski fakultet, Sveučilište u Zagrebu, Hrvatska

² Tehničko veleučilište u Zagrebu, Hrvatska

Sažetak. U ovom ćemo radu djelomično okarakterizirati način podučavanja matematike, posebice početnog učenja množenja u hrvatskom obrazovnom sustavu. Budući je podučavanje socio-kulturalni fenomen, kako bi ga se opisalo, potrebno je iskoračiti iz danog kulturalnog okvira jer tek tada možemo uočiti neke njegove atribute koji se iznutra čine očiglednima. Zbog toga smo usporedili tretman početnog učenja množenja, uključujući tablicu množenja, u udžbenicima iz Hrvatske i Singapura. U analizi udžbenika koristili smo prilagođeni okvir Charalambous, Delaney, Hsu i Mesa (2010) koji na udžbenik gleda kao na okruženje za konstrukciju znanja o pojedinom matematičkom konceptu.

Ključne riječi: matematički udžbenici, analiza formiranja koncepta, početno množenje

What types of knowledge do mathematics textbooks promote?

Amanda Glavaš¹, Azra Staščik² and Ljerka Jukić Matić³

¹Mechanical Engineering School Osijek, Croatia

²Elementary school Dobriša Cesarić Osijek, Croatia

³Department of Mathematics, University of Osijek, Croatia

Abstract. This paper reports a study on the type of mathematical tasks and their overall representation in mathematics textbooks. The aim of the study was to investigate the ratio of tasks according to the main classification on procedural and conceptual tasks according to the type of knowledge one accessed to obtain a solution. The study provides further insight into the classification of each type of tasks by categories established by the researcher according to Rittle – Johnson and Schneider (2015) categorization. The study was conducted on two out of three mathematics textbooks approved by the Ministry of Science and Education of Republic of Croatia and covered two chapters from two different mathematics domains. The findings showed that procedural tasks were vastly present in investigated textbooks, unlike conceptual tasks. Based on these findings we argue for an increase of conceptual tasks in mathematics textbooks. Our argument stems from previous studies which advocate a balance of procedural and conceptual knowledge in teaching and learning mathematics. Further, we find the results disappointing since numerous studies show that textbooks play one of the main and almost central role in teachers' lesson preparation, as well as in the selection of tasks used during teaching phase and practicing phase of the lesson.

Keywords: procedural tasks, conceptual tasks, textbooks, teaching mathematics, textbooks' analysis

1. Introduction

Mathematics education traditionally places a strong emphasis on textbook use. Textbooks, in a printed or digital form, are still one of the most used resources in mathematics education (Fan, Zhu & Miao, 2013) and heavily influence educational practice (Lepik, Grevholm & Viholainen, 2015). They can be seen as a potentially

implemented curriculum i.e. as a mediator between general intentions and classroom instruction, turning policy into pedagogy (Valverde, Bianchi, Wolfe, Schmidt & Houang 2002). They also affect teacher's work in a number of different ways; teachers use them for planning and enacting a lesson (Pepin & Haggarty, 2001, Jablonka & Johansson, 2010, Glasnović Gracin & Jukić Matić, 2016).

Textbooks are important for students' learning also. Studies that examined how mathematics textbooks influence instruction generally agree that textbooks have a significant influence on students' opportunities to learn mathematics (Stylianides, 2009). The textbook, which teacher uses, influences on what students learn, how they learn, and the cognitive level at which they learn (Grouws et al., 2013; Stein, Remillard & Smith, 2007).

The analysis of textbook can help us understand policy documents, such as national curriculum, and how they are manifested in the classroom by textbooks (McDonnell, 1995). In Croatian context, Glasnović Gracin (2018) analyzed textbook activities in most commonly used lower secondary mathematics textbook. The results showed that there is an emphasis on algorithms, while argumentation and interpretation activities, reflective thinking and open-ended problems are underrepresented. This picture of mathematics as a set of algorithms reveals a more traditional than a contemporary view of mathematics. The content analysis also showed that the requirements of the intended curriculum match the ones in the textbooks (Glasnović Gracin, 2018), thus the Croatian mathematics textbook can be perceived as a conveyor of the curriculum (Fan et al., 2013).

The aforementioned considerations, describing the multifaceted role of the textbooks, incited us to investigate Croatian upper secondary mathematics textbook through the lens of opportunities to learn.

2. Theoretical background

2.1. The textbooks and opportunities to learn

Opportunities to learn (OTL) can be used as a measure of whether students had the opportunity to study a particular topic or to learn how to solve a particular type of problem (Jäder, Lithner & Sidenvall, 2015). Törnroos (2005) pointed out that this definition, although simple, can be interpreted in several ways. One approach is to evaluate the opportunity to learn in terms of how much emphasis a topic receives in written resources, for example in a curriculum or a textbook. Other interpretations may consider an opportunity to learn as the time devoted to a topic during instruction i.e. as the length of time that a teacher has planned to spend discussing the topic, as the time a teacher actually spends teaching it, or as the time students are truly engaged in learning it.

Schmidt et al. (2001) have shown that there is a clear relationship between textbooks and students' achievement. They analyzed the United States TIMSS 1995 eighth grade data and found a direct relationship between the amount of space allocated to covering a topic and students' achievement on that topic.

Similar findings were reported by Törnroos (2005). He examined the influence of nine mathematics textbooks series used in the classes of the TIMSS 1999 sample in Finland on students' achievement in the TIMSS mathematics test. It turned out that the number of learning opportunities, which textbook provided specifically for the content of TIMSS items, was significantly positively correlated with students' performance in the TIMSS test. Furthermore, Hadar (2018) reports that students have higher scores on a standardized national exam if they are using the textbook which provides the opportunity to engage in tasks demanding higher levels of understanding.

From this aspect, a textbook analysis presents a first step in understanding what happens in the mathematics classrooms and what students take as relevant and necessary knowledge to acquire. The activities that students are presented within the classroom and as well as their experiences give students the idea of what qualifies as mathematical knowledge.

2.2. Types of knowledge

Concept – process approach is a relevant and widely accepted theoretical framework in mathematics education research (Haapasalo & Kadjevich, 2000, Star, 2005). Conceptual knowledge provides an understanding of the principles and relations between pieces of knowledge in a certain domain, and procedural knowledge enables us to quickly and efficiently solve problems (Hiebert & Lefevre, 1986). According to Haapasalo & Kadjevich (2000), the above definition of procedural and conceptual knowledge may lead to the conception that procedural knowledge is dynamic and conceptual knowledge static. Their definition also highlights the dynamic nature of conceptual knowledge. Procedural knowledge is dynamic utilization of algorithms or procedures within representation forms, and conceptual knowledge denotes the ability to browse through a network consisting of concepts, rules, algorithms, procedures and even solved problems in various representation forms. Furthermore, they underline conceptual knowledge as knowledge which enables conduction of cognitive processes on the higher level of knowledge such as classification, categorization, specialization, generalization, induction, deduction, analysis, synthesis, abstraction and analogy. In other words, the ability to elaborate, connect, organize or apply facts and pieces of information we define as a functional structure of conceptual knowledge. On the other hand, procedural knowledge is defined as the ability to execute procedures or sequenced action to solve a problem given (Rittle-Johnson & Schneider, 2015). It is expected to develop this kind of knowledge through solving practice, therefore, is related to a certain set of problems.

Star (2005) claimed that using the terms conceptual and procedural knowledge confuses knowledge types with knowledge quality. He offered new a definition in which conceptual knowledge could be better understood in terms of “knowledge of concepts and principles” and procedural knowledge in terms of “knowledge of procedures”. Star argued that both conceptual and procedural knowledge may be deep and superficial. He opposed the notion that procedures are understood only

when conceptual knowledge become involved. His definitions identify flexibility as a crucial component of deep procedural knowledge. This denotes knowledge of multiple methods for solving a class of problems and the ability to choose the most appropriate among the method for the given problem.

Depending on the type of knowledge which tasks demands for solving, we can classify tasks as being either conceptual or procedural. Conceptual tasks would be tasks that require conceptual knowledge in order to come to a solution, and procedural would be those that demand procedural knowledge. However, often a classification of tasks is not so obvious, and tasks must be examined in relation to the solver and certain context. According to Rittle-Johnson & Schneider (2015), one of the most critical features of conceptual tasks is that they often present novelty to participants, so participants have to browse through existing knowledge and derive an answer from their conceptual knowledge, instead of implementing a known procedure for solving the task. They argue that procedural task always requires solving routine problems, and we usually measure the result according to the accuracy of the answers or procedures. It is possible that procedural tasks include near transfer problems. Those are “familiar problems with an unfamiliar problem feature that require either recognition that a known procedure is relevant or small adaptations of a known procedure to accommodate the unfamiliar problem feature” (Rittle-Johnson and Schneider, 2015, p.1123). This means that the problem itself is familiar to a participant, but there is an unfamiliar problem feature.

In order to advance mathematical competences, it is very important to develop both conceptual and procedural knowledge equally. Rittle-Johnson & Schneider point out that mathematical competence develops when one acquires both conceptual and procedural knowledge. Moreover, they claim that the relations between conceptual and procedural knowledge are often bidirectional and iterative. Additionally, NCTM (2000) proposes an equal representation of conceptual and procedural knowledge as a key for all levels of learning.

2.3. Research questions

In this study, an opportunity to learn was approached as the proportion of textbooks dedicated to procedural and conceptual tasks. Therefore, we formed the following research questions:

- a) What opportunities to learn do textbooks provide in relation to procedural and conceptual tasks and to what extent?
- b) Is there any difference in the distribution of conceptual and procedural tasks among different mathematical domains (numbers and geometry)?
- c) What are the differences between analyzed textbooks according to the types of tasks?

3. Methodology

3.1. Sample

The content analysis was conducted on primary sources, two out of three mathematics textbooks approved by the Ministry of Science and Education of Republic of Croatia. Aforementioned textbooks are provided by two different publishers (codes D and K) and intended for the first grade of upper secondary school. We chose one chapter from the domain of numbers and algebra (chapter Real numbers) and the other one from the domain of geometry (chapter Congruence and similarity). The chapter Real numbers includes topics on whole numbers, integers, rational numbers, real numbers, percentage, arithmetic mean and intervals. The chapter Congruence and similarity includes topics on congruence of segment and angles, congruence of triangles, geometrical proportion and Theorem of Thales, similarity of triangles, homothetic transformation and Theorem of Euclid. The study was conducted on two different mathematical domains to ensure the randomness of the sample and prevent it to be influenced by the specificity of content (Mužić, 1982). This is also in line with Schimdt et al. (2001) who claim that the study of specific mathematics topics is very valuable in investigating students’ opportunities to learn.

3.2. Analytical framework

The content analysis was based on Rittle-Johnson’s and Schneider’s (2015) characterization of procedural and conceptual tasks. Before the content analysis took place, an initial examination of tasks contained in both textbooks was carried out. First examinations prompted establishing rough categories by which tasks could have been classified. Next, categories were proposed by the first and second author among themselves. Finally, reaching consensus, categories were set and then detail examination took place. In addition, a table was designed in accordance with the research aim containing categories for each type of tasks (Table 1). That established qualitative as well as quantitative potentials and this way we wanted to ensure consistency between two independent researchers. Meaning, the researcher had to classify each examined task in one of the categories established and agreed on in advance.

Table 1. The table used for tasks analysis

Task	Researcher 1							Note	Task	Researcher 2							Note	
	Procedural			Conceptual						Procedural			Conceptual					
	P1	P2	P3	C1	C2	C3	C4			P1	P2	P3	C1	C2	C3	C4		

The task was categorized as *procedural* if it possessed one of the following features:

- P1: “algorithms – a predetermined sequence of actions that will lead to the correct answer when executed correctly” (Rittle-Johnson & Schneider, 2015, p. 1119) and application of definitions and formulas

Example (Textbook K):

Calculate: $\frac{0.8 - \frac{4}{3}}{\frac{3}{2} \cdot 0.4}$

- P2: the type of task already solved as a worked example in the textbook

Example (Textbook K):

The solved example on how to construct a triangle when we know the length of all 3 sides, $a = 5$ cm, $b = 6$ cm, $c = 4$ cm is given in the textbook. Afterwards, the task follows:

“Construct triangle whose sides are $a = 6.5$ cm, $b = 7.3$ cm, $c = 5.2$ cm”.

- P3: the tasks which include near transfer problems

Example (Textbook D):

Task 1. 200 000 pieces of bricks are needed for construction. If the waste represents 4.5% of the total amount, how many pieces do we need for the construction?

Task 2. (near transfer): One has to pay 600 HRK for the transport of goods, which is 1.5% of the goods value. What is the value of goods?

The task was categorized as *conceptual* if it possesses one of the following features:

- C1: make a categorical choice (e.g. judge the correctness of an example procedure or answer and explanation)

Example (Textbook K):

Does a triangle given by $a = 12$ cm, $b = 14$ cm, $\alpha = 75^\circ$ exist?

- C2: encode key features (“Success reconstructing examples from memory (...) with the assumption that greater conceptual knowledge helps people notice key features and chunk information, allowing for more accurate recall.” (Rittle-Johnson and Schneider, 2015, p.1121))

Example (Textbook D):

The lengths of the triangle sides are 4, 13 and 15. Length of altitude on the shortest side of a similar triangle equals 18. What are the sizes of the sides of the similar triangle?

- C3: finding proof or formula

Example (Textbook D):

Prove that altitudes on two legs of isosceles triangles are congruent.

- C4: invent principle-based shortcut procedures

Example (Textbook D):

What is the last digit of product $1 \cdot 3 \cdot 5 \cdot \dots \cdot 99$?

3.3. Data analysis

After each researcher categorized tasks independently, the data were compared to find opposite judgments and to discuss them. In cases we could not agree to which category certain task should be assigned, we decided to eliminate them from further analysis.

This process provided triangulation. Triangulation can be defined as the utilization of two or more procedures while data collecting (Cohen, Manion & Morrison, 2007). In our research, we used investigator triangulation to overcome the weakness or intrinsic biases and the problems that come from single method and single observer. Each researcher has an individual style which provides more reliable and valid data.

4. Results

4.1. Tasks requirements

Results show that the vast number of tasks in textbooks are procedural tasks. If we count the number of tasks from both textbooks, there are in total 1037 tasks. Among them, there are 895 procedural tasks and 142 conceptual tasks, which means 86% of all tasks are procedural and 14% are conceptual (as shown in Figure 1).

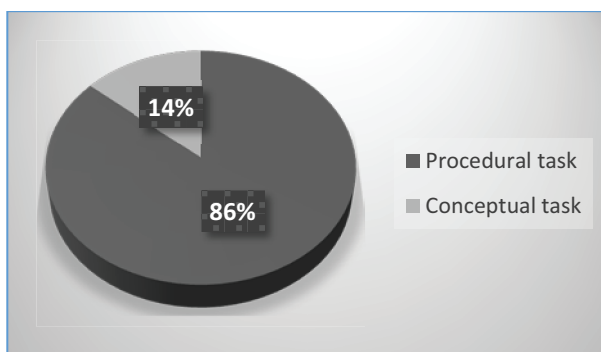

Figure 1. Distribution of tasks in two textbooks

Figure 2 shows the distribution of procedural tasks in categories described in the previous section. Category P1 includes tasks which require algorithms, application of formulas and definitions and they represent almost half (48.7%) of all procedural tasks. Category P2 includes tasks which have a similar counterpart as the worked example given in the textbook. This category contains 21.7% of all procedural tasks. Category P3 includes tasks which require near transfer in the procedure. This category contains 29.6% of all procedural tasks.

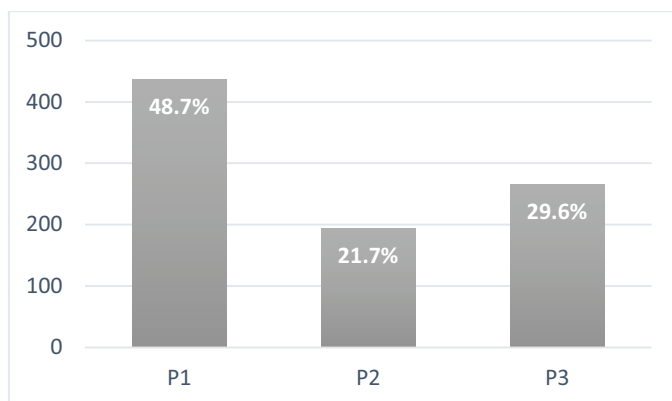

Figure 2. Distribution of procedural tasks among three subcategories

Distribution of conceptual tasks among four subcategories is shown in Figure 3. As can be seen, the most frequent conceptual tasks belong to the category C2 (43.8%) which require encoding key features. On the other hand, tasks that belong to the category C3, where finding proof or formula is needed, represent 25.5% of all conceptual tasks. Least represented conceptual tasks belong to the category C1 (making a categorical choice) with 17.6% and category C4 (the invention of the principle-based procedure) with 13.1% of all conceptual tasks.

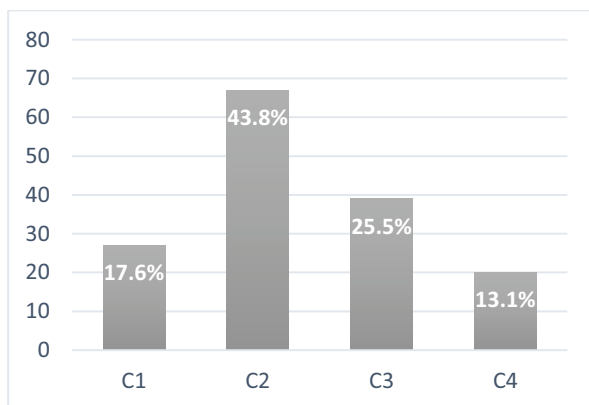

Figure 3. Distribution of conceptual tasks among three subcategories

Data shown in Figure 4 present joint distribution of procedural and conceptual tasks from both textbooks among different mathematical domains (numbers and geometry). There are 5 times more conceptual tasks in textbook chapters dealing with geometry, i.e. Congruence and similarity (26%) than in textbook chapters dealing with numbers, i.e. Real numbers (5%).

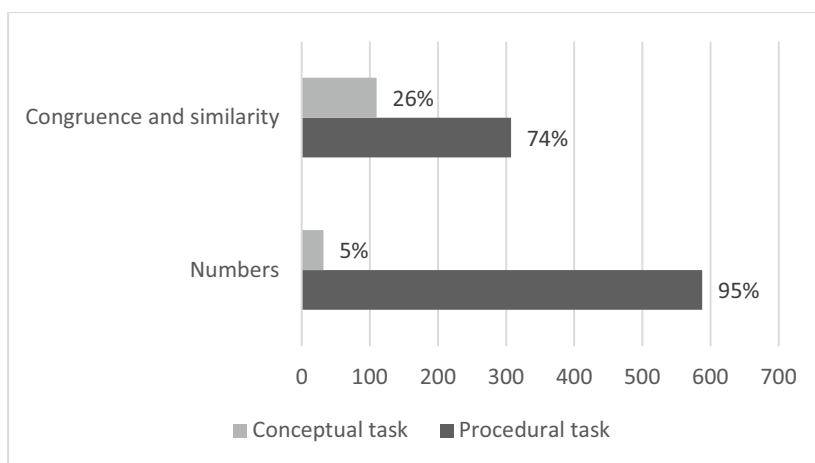

Figure 4. Distribution of tasks among mathematical domains

4.2. Textbook differences

To be classified in the category of procedural or conceptual tasks, the task has to be examined in the context of the unit, other tasks, shown examples, given background of theory, etc. While doing the research, we found several same tasks in both textbooks, but they are categorized in different categories, or even as a different type of task. For instance, the task from one textbook is categorized as conceptual and from the other one as procedural. Example of such a task is: “*Prove that triangles are congruent if they are matching in two angles and one altitude.*” In Textbook K it is conceptual (C3), but in Textbook D it is a procedural task (P2) because the same example (with different labels) is solved in the textbook. Furthermore, one task can be both, procedural and conceptual and it depends on how it is solved. For example, in Textbook K: “*Diagonals of quadrilateral divide it into 4 congruent triangles. Which quadrilateral it is?*” This task is placed in exercises and follows the task given before: “*Prove that diagonals of rhombus divide it into 4 congruent triangles.*” So, this can be near transfer procedural task if that task is already solved, otherwise, it is conceptual (C3). In that case, researchers assumed the tasks in part of exercise had been solved, therefore it is classified as a procedural task.

Another example is the following task: “*If you know that $\frac{1}{3} = 0.\dot{3}$, what is $\frac{1}{30}$?*” This task can be conceptual (C4) and procedural (P1). If a student makes a connection between these two fractions and creates short-based procedure on how to calculate it, then it is conceptual. However, if the student applies procedure on how to transform fraction into a decimal number, then it is a procedural task (P1). Therefore, the task can be solved relying only on the procedure, without linking particular concepts. In what way the task will be solved, and consequently classified, depends on the level of knowledge student possesses on a particular subject.

Figure 5 shows the distribution of conceptual and procedural tasks in each textbook. In Textbook K there are more procedural tasks (91%) than in Textbook D (78%).

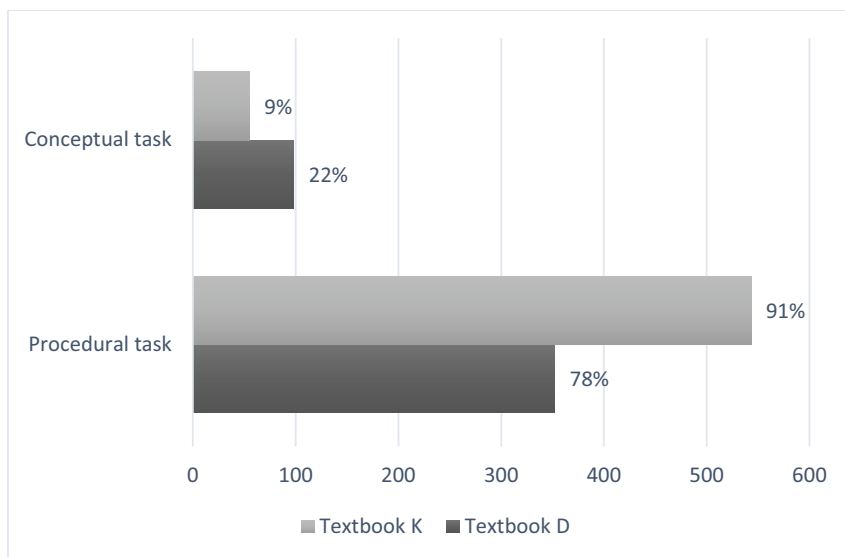

Figure 5. Comparison of tasks in textbooks

5. Discussion and conclusion

Procedural and conceptual knowledge are important for building strong mathematical competence (Hiebert, 2003). To obtain that competence, students need opportunities to learn. The textbook, as the most used resource for teaching and learning, certainly provides this opportunity. Shield and Dole (2013) argue that a textbook analysis is the first level of finding out what opportunities to learn are available to students. The results of our textbook analysis, conducted on two mathematical domains, numbers and geometry, from upper secondary school, show the dominance of procedural tasks over conceptual ones. The textbook D does offer more conceptual tasks than textbook K, but the proportion of procedural task in this textbook is still significantly greater than the proportion of conceptual ones. In all, the tasks in both textbooks are connected with applying a familiar algorithm that seems appropriate for the situation. This exemplifies the utilization of imitative reasoning and promoting superficial procedural knowledge. Therefore, the Croatian upper secondary mathematics textbooks provide more opportunities for students to engage with procedural tasks than with conceptual ones.

Similar findings, the dominance of imitative reasoning and procedural knowledge in tasks from geometry (perimeter, area, volume) and algebra (formulas equations), have been reported in the study of Jäder et al. (2015). Analyzing

mathematics textbooks from 12 countries, they discovered that most tasks in the textbooks enabled practicing of algorithms, while smaller part, around 10-20% are focused on intrinsic mathematical properties, requiring deep conceptual knowledge.

Moreover, a relationship between the textbook and the learning outcomes, and the textbook and classroom instructions has been shown in several different contexts (Schmidt, 2012). Building upon those relations, the results of our study indicate that teaching mathematics in many upper secondary classrooms is focused on practicing procedural tasks and, consequently, obtaining procedural knowledge.

Based on these findings we argue for an increase of conceptual tasks in mathematics textbooks. Our argument stems from previous studies which advocate a balance of procedural and conceptual knowledge in teaching and learning mathematics (Star, 2005, Rittle-Johnson & Schneider, 2015). Building both types of knowledge enables the flexibility of students' thinking and develops adequately mathematical competence. Further, we find the obtained results quite disappointing since numerous studies show that textbooks play one of the main and almost central role in teachers' lesson preparation, as well as in the selection of tasks used during teaching phase and practicing phase of the lesson. However, there is more to the opportunities to learn than the textbook. Thus, to gain better insight into what other opportunities to learn student have, new studies should be conducted focusing on teachers' classroom practice and analysis of materials which teacher also uses in classroom enactment.

References

- [1] COHEN, L., MANION, L. & MORRISON, K. (2007). *Research methods in education*. Abingdon: Routledge.
- [2] FAN, L., ZHU, Y. & MIAO, Z. (2013). Textbook research in mathematics education: development status and directions. *ZDM –Mathematics Education*, 45(5), 633–646.
- [3] GLASNOVIĆ GRACIN, D. (2018). Requirements in mathematics textbooks: a five-dimensional analysis of textbook exercises and examples. *International Journal of Mathematical Education in Science and Technology*, 49(7), 1003–1024.
- [4] GLASNOVIĆ GRACIN, D. & JUKIĆ MATIĆ, LJ. (2016). The Role of Mathematics Textbooks in Lower Secondary Education in Croatia: An Empirical Study. *The Mathematics Educator*, 16(2), 29–56.
- [5] GROUWS, D. A., TARR, J. E., CHAVEZ, O., SEARS, R., SORIA, V. M. & TAYLAN, R. D. (2013). Curriculum and implementation effects on high school students' mathematics learning from curricula representing subject-specific and integrated content organizations. *Journal for Research in Mathematics Education*, 44(2), 416–463.
- [6] HAAPASALO, L. & KADIJEVICH, D. (2000). Two types of mathematical knowledge and their relation. *Journal for Mathematik-Didaktik*, 21(2), 139–157.
- [7] HADAR, L. L. (2017). Opportunities to learn: Mathematics textbooks and students' achievements. *Studies in Educational Evaluation*, 55, 153–166.

- [8] HIEBERT, J. (2003). What research says about the NCTM standards. In J. Kilpatrick, G. Martin & D. Schifter (Eds.), *A research companion to the principles and standards for school mathematics*, pp. 5–23, Reston, VA: National Council of Teachers of Mathematics.
- [9] HIEBERT, J., & LEFEVRE, P. (1986). Conceptual and Procedural Knowledge in Mathematics: An Introductory Analysis. In J. Hiebert (Ed.), *Conceptual and Procedural Knowledge: The Case of Mathematics*, pp. 1–27. Hillsdale, NJ: Lawrence Erlbaum Associates.
- [10] JABLONKA, E. & JOHANSSON, M. (2010). Using texts and tasks: Swedish studies on mathematics textbooks. In B. Sriraman, C. Bergsten, S. Goodchild, G. Pálsdóttir, B. Dahl & L. Haapasalo (Eds.), *The first sourcebook on Nordic research in mathematics education*, pp. 363–372, Charlotte: Information Age Publishing.
- [11] JÄDER, J., LITHNER, J., & SIDENVALL, J. (2015). Reasoning requirements in school mathematics textbooks: an analysis of books from 12 countries. In J. Jäder (Ed.), *Elevers möjligheter till lärande av matematiska resonemang* (Licentiate thesis).
- [12] LEPIK, M., GREVHOLM, B., & VIHOLAINEN, A. (2015). Using textbooks in the mathematics classroom – the teachers’ view. *Nordic Studies in Mathematics Education*, 20(3–4), 129–156.
- [13] MCDONNELL, L. M. (1995). Opportunity to learn as a research concept and a policy instrument. *Educational Evaluation and Policy Analysis*, 17(3), 305–322.
- [14] MUŽIĆ, V. (1982). *Metodologija pedagoškog istraživanja*. Mužić, V. (1982), Metodologija pedagoškog istraživanja. Sarajevo: Zavod za izdavanje udžbenika.
- [15] National Council of Teachers of Mathematics [NCTM] (2000). *Principles and standards for school mathematics*. Reston, VA: National Council of Teachers of Mathematics.
- [16] PEPIN, B. & HAGGARTY, L. (2001). Mathematics textbooks and their use in English, French and German classrooms: a way to understand teaching and learning cultures. *ZDM – Mathematics Education*, 33(5), 158–175.
- [17] RITTLE-JOHNSON, B., & SCHNEIDER, M. (2015). Developing conceptual and procedural knowledge in mathematics. In R. Cohen Kadosh & A. Dowker (Eds.) *Oxford handbook of numerical cognition*, pp. 1118–1134, Oxford University Press. doi: 10.1093/oxfordhb/9780199642342.013.014
- [18] SCHMIDT, W. (2012). Measuring content through textbooks: The cumulative effect of middle-school tracking. In G. Gueudet, B. Pepin & L. Trouche (Eds.), *From text to ‘lived’ resources: Mathematics curriculum materials and teacher development*, pp. 143–160. Dordrecht: Springer.
- [19] SCHMIDT, W. H., MCKNIGHT, C. C., HOUANG, R. T., WANG, H., WILEY, D. E., COGAN, L. S., ET AL. (2001). *Why schools matter: A cross-national comparison of curriculum and learning*. The Jossey-Bass education series. San Francisco, CA: Jossey-Bass.
- [20] SHIELD, M., & DOLE, S. (2013). Assessing the potential of mathematics textbooks to promote deep learning. *Educational Studies in Mathematics*, 82(2), 183–198.
- [21] STAR, J. R. (2005). Reconceptualizing procedural knowledge. *Journal for Research in Mathematics Education*, 36(5), 404–411.
- [22] STEIN, M. K., REMILLARD, J.T. & SMITH, M. S. (2007). How curriculum influence student learning. In F.K. Lester (Ed.), *Second handbook of research on mathematics teaching and learning*, pp. 319–369. Charlotte, NC: Information Age Publishing.

- [23] STYLIANIDES, G. J. (2009). Reasoning-and-proving in school mathematics textbooks. *Mathematical Thinking and Learning*, 11(4), 258–288.
- [24] TÖRNROOS, J. (2005). Mathematics textbooks, opportunity to learn and student achievement. *Studies in Educational Evaluation*, 31(4), 315–327.
- [25] VALVERDE, G., BIANCHI, L. J., WOLFE, R., SCHMIDT, W. H., & HOUANG, R. T. (2002). *According to the book: Using TIMSS to investigate the translation of policy into practice through the world of textbooks*. Netherlands: Springer.

Contact addresses:

Amanda Glavaš
Mechanical Engineering School Osijek
Istarska 3, 31000, Osijek, Croatia
e-mail: glavas.amanda@gmail.com

Azra Stašćik
Elementary school Dobriša Cesarić Osijek
Neretvanska 10, 31000, Osijek, Croatia
e-mail: azra.stascik@gmail.com

Ljerka Jukić Matić
Department of Mathematics, University of Osijek,
Trg Ljudevita Gaja 6, 31000, Osijek, Croatia
e-mail: ljukic@mathos.hr

Koju vrstu znanja promoviraju matematički udžbenici?

Amanda Glavaš¹, Azra Staščik² i Ljerka Jukić Matić³

¹Strojarska i tehnička škola Osijek, Hrvatska

²Osnovna škola Dobriša Cesarić Osijek, Hrvatska

³Odjel za matematiku, Sveučilište u Osijeku, Hrvatska

Sažetak. Ovaj rad donosi rezultate istraživanja o vrsti matematičkih zadataka i njihovoj zastupljenosti u udžbenicima matematike. Cilj je istraživanja bio ustanoviti omjere zadataka prema jednoj od čestih podjela: na proceduralne i konceptualne zadatke. Rad također donosi uvid u dublju klasifikaciju svake od navedenih vrsta zadataka, koju su autori osmislili prema klasifikaciji danoj u Rittle-Johnson i Schneider (2015). Istraživanje je koncentrirano na matematičke udžbenike za srednje škole s četverogodišnjim programom. Istraživanje je provedeno na dva od tri prihvaćena i odobrena udžbenika, od strane Ministarstva znanosti i obrazovanja Republike Hrvatske, a pokrivena su dva različita matematička područja. Rezultati pokazuju kako su proceduralni zadatci u udžbenicima uvelike zastupljeni, za razliku od konceptualnih zadataka. Vodeći se dobivenim rezultatima, zagovaramo povećanje konceptualnih zadataka u matematičkim udžbenicima. Naš zaključak proizlazi iz ranijih istraživanja koja pokazuju kako velika vrijednost leži u podjednakom poučavanju proceduralnog i konceptualnog znanja. Rezultate proizašle iz ovog istraživanja smatramo još nepovoljnijima jer mnoga istraživanja pokazuju kako su udžbenici jedan od glavnih elemenata koji utječu na pripremu nastave nastavnika, kao i na izbor zadataka koji će se koristiti za učenje i vježbanje.

Ključne riječi: proceduralni zadatci, konceptualni zadatci, udžbenici, poučavanje matematike, analiza udžbenika

4.

Approaches to teaching and learning mathematics

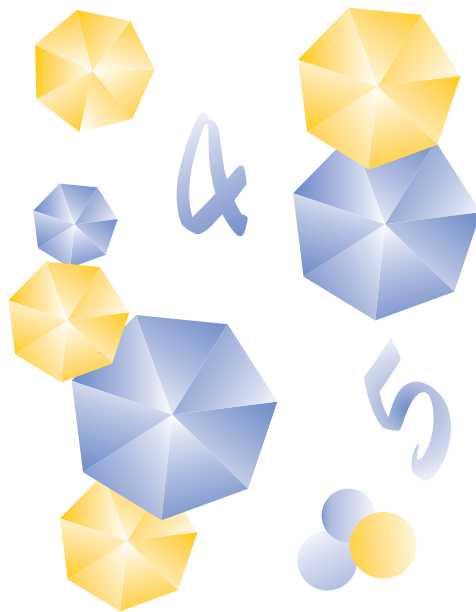

How do novices and experts approach an open problem?

Zoltán Kovács¹ and Eszter Kónya²

¹Institute for Mathematics and Computer Science, University of Nyíregyháza, Hungary

²Institute for Mathematics, University of Debrecen, Hungary

Abstract. There are well-known differences between problem solving competencies of novices and experts. It is also known from the literature that students, regardless of age, typically give the expected answer, ignoring the openness of the problem. In our study, we use a problem that is open at the starting point nevertheless it has closed solution. We analyze how experts and novices manage the openness of an elementary problem based on a survey prepared for 7th and 8th graders.

Keywords: open problem, realistic reaction, novice and expert problem solver

1. Introduction

We know from the literature and our experience as teacher that for students open mathematical problems (including realistic problems) can be very problematic to deal with. Students, regardless from their age, have difficulties with recognition of the realistic content of mathematical tasks (Verschaffel, de Corte, & Lasure, 1994). They give stereotyped answers for tasks in most of the case on mathematics lessons ignoring their open nature. Other research (Ambrus, Herendiné Kónya, Kovács, Szitányi, & Csíkos, 2019) suggests that the root of giving stereotyped answers is not the age of the students. In that study answers of 1346 students from Grade 2 to Grade 10 were analyzed and the conclusion is that even students of Grade 10 gave the expected answer without any hint on the real-life experience regarding the open realistic problem.

In this study, we refine the overall verdict by examining separately the novices' and experts' reactions to an open problem. Our hypothesis is that there are consid-

erable differences between the results of beginners and advanced problem solvers in the fine structure of the generally poor results. We also claim that in terms of success, expert-novice differences are not caused primarily by age, but by more advanced problem-solving skills.

Our hypothesis is supported by a preliminary research where we compared performances of two groups of 5th graders (see the Appendix of this paper). The expert group was made up of 28 children from a mathematical competition who came from different Hungarian schools. In the novice group, there were 57 fifth grade students from a regular school. Their performance was evaluated in an open problem that was set in the competition. We found statistically significant difference in handling the openness of the problem. In the research reported here we refined the design of the preliminary research. The difference is that we have redefined the ‘expert’ status. However, we kept the original problem of the preliminary survey.

Therefore, we tried to find such kind of student population which can handle the openness of the problem, to recognize not only the surface but the deep structure of it and finally solve it correctly. We assumed that experienced problem solvers i.e. the experts, understand the deep structure of an open problem, so they can solve it in a proper way. By contrast, novices recognize only the surface structure of the problem and give the expected answer ignoring the openness feature of the problem. We conducted a survey in such a way that we choose two groups of the same age (Grade 7-8). The difference between the two groups is that some students (experts) are specialized in mathematics (7 math lessons per week), while others (novices) in language or art subjects (3 math lessons per week).

2. Theoretical background

Literature uses the words ‘novice’ and ‘expert’ in many ways, see e.g. in Leithwood’s and Steinbach’s (1995) meta-analysis. The authors propose the following definition. “Expertise is defined as (a) the possession of complex knowledge and skill; (b) its reliable application in actions intended to accomplish generally endorsed goal states; and (c) a record of goal accomplishment, as a consequence of those actions, which meets standards appropriate to the occupation or field of practice, as judged by clients and other experts in the field.” (Leithwood & Steinbach, 1995, p. 13). They use these notions in a wider sense than expertise in mathematical problem solving, but we agree that items (a) and (b) fit on this area, too. This definition approaches the definition of the expert from the attributes. In our research we need a more practical approach. Presumably, expert-novice differences in problem perception are rooted in difference in training and experience. In this research, expert is the student who received special courses on problem solving, while novice is the student who didn’t. This conception is quite similar to the way as Schoenfeld and Hermann (1982) used these notions in the area of mathematical problem solving. That study explored the relationship between problem perception and proficiency directly. Students’ perceptions of the structure of mathematical problems were examined before and after a monthlong intensive

course on mathematical problem solving. These perceptions were compared with experts' perceptions. After the course the students perceived problem relatedness more like the experts.

Several studies have found that the strategies used by expert and novice problem solvers differ (Sweller, Mawer, & Ward, 1983), furthermore there is a close relationship between expertise and problem perception. Schoenfeld and Hermann showed that "in the broad domain of general mathematical problem solving, students with similar backgrounds will perceive problems in similar ways. . ." (Schoenfeld & Herrmann, 1982, p. 491). Whereas the novice recognizes the surface structure of the problem, the expert categorizes problems according to solution strategies. The applied method of solution highlights the deep structure of a mathematical problem. In school mathematics the curriculum is organized around topics rather than around problem solving methods. It means that novices, who have less experiences on problem solving than experts, obviously have less chance to discover the deep structure of problems than experts have. The perception of deep structure of a problem is crucial point related to the successful solution.

In order to study the way of problem perception of students, our attention turned to open problems, because open problems obviously give the possibility of multiple answers or application of different solving methods. In line with Pehkonen (1997), we categorize a task as open, if their starting or goal situation is not exactly explained. In our study we analyze the solutions of an open problem, whose starting situation is not exactly given, but the goal situation is clear. The context of the problem is a realistic situation, i.e. a situation that can be easily experienced by children, moreover it needs mathematical modelling.

We agree with Verschaffel et al. (1994) that stereotyped word problems in school mathematics "exclude real-world knowledge and realistic considerations from the different stages of their solution processes, i.e. the initial understanding of the problem, the construction of a mathematical model, the actual computational activities, and the interpretation and evaluation of the outcome of these computations". (Verschaffel, de Corte, & Lasure, 1994, p. 273). Accordingly, the right interpretation of our problem is crucial in the following stages: initial understanding of the problem and construction of a mathematical model.

3. Research question

Q1: Are there any differences regarding the recognition of the openness of mathematical problems between experts and novices?

Q2: Are there any differences regarding the quality of elaboration of solution between experts and novices who recognize the openness of a problem?

4. Methodology

The survey was done in February 2019.

4.1. The sample

One of the distinctive virtues of the special mathematics classes in Hungary is the talent care in classroom environment. There are two types of special mathematics training, the four-grade program (grades 9-12) and the six-grade program (grades 7-12). There are five schools in three different cities that have the six-grade program. We have chosen three Hungarian schools from three geographical locations (Budapest, Debrecen, and Miskolc) where there are programs for six-grade special mathematics classes. All 7th and 8th Grade students from special mathematics classes from these schools participated in this survey. We consider these pupils experts in this study. The circumstances meet the criteria for “expert” in the sense of Schoenfeld and Hermann (1982), because the students have special training in problem solving in school. We have also chosen novice students from these schools. Likewise, all 7th and 8th grade students from art specialization participated in the survey. We assume that the students’ cognitive competencies and the attitude towards training are very similar, because students need high score in mathematics and Hungarian language to entrance these special classes regardless the type of the specialization. Table 1 shows the number of participants of the survey.

Table 1. Number of students took part in the survey.

	Budapest	Debrecen	Miskolc	Total
Expert	55	63	64	182
Novice	59	54	64	177
Total	114	117	128	359

We agree with Schoenfeld and Hermann, that this design refers only indirectly to the expert-novice difference in problem perception, because students may differ in other psychological properties, e.g. aptitude. However, we try to minimize this effect choosing the expert and novice groups from the same above-average school in all the three cities.

4.2. The “Four children” problem

The problem used in the survey is the following:

Anna, Béla, Cili and Dani are standing along a straight line. Anna is 5 meters from Béla, Béla is 3 meters from Cili, while Cili is 1 meter from Dani. How many meters may be Dani from Anna?

We consider the problem open, because there is no explicit hint to the order of children (Pehkonen, 1997).

The surface of the problem suggests the expected answer: assuming the ABCD order of the four children, the distance between A and D is 9 meters. In contrast, four sequences are possible: ABCD, ABDC, ACBD, ADCB, so the distance between Anna and Dani can be 9 m, 7 m, 3 m, 1 m respectively (Figure 1).

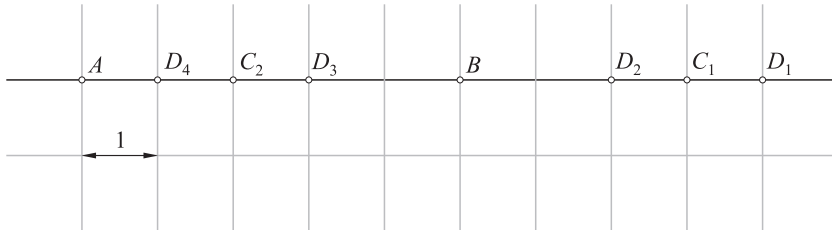

Figure 1. Four possible solutions of the ‘Four children’ problem.

The teachers who supervised the survey in a class received guidance before the survey how to react if a question arose while the students were working. A general rule was to avoid any help and give only neutral answers such as to read the text again. The time available for work was 10 minutes.

4.3. The coding system

In order to classify students’ reactions to the ‘Four children problem’ we adapted the coding system of Verschaffel et al. (1994). We kept three main categories (EA, RA, OA, see in what follows) that have similar meaning. Outside the main categories we used two other categories (EA+ and RA–), thus five categories of students’ reactions were distinguished in our research.

- Expected answer (EA). We apply this code when pupil gives only one answer. In most cases it is 9, that is, the number the text suggests (Figure 2).

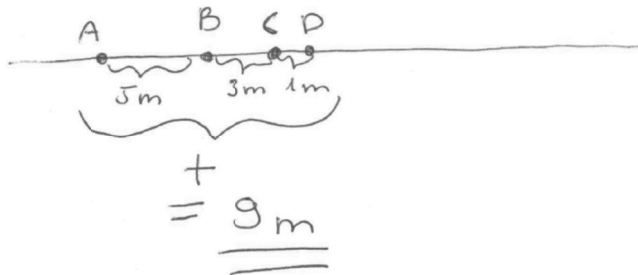

Figure 2. An example of ‘EA’ reaction.

- Expected answer with realistic hint (EA+). If the pupil gives one answer but some trace of hesitation is found without any numerical considerations a ‘+’ sign is added (Figure 3).

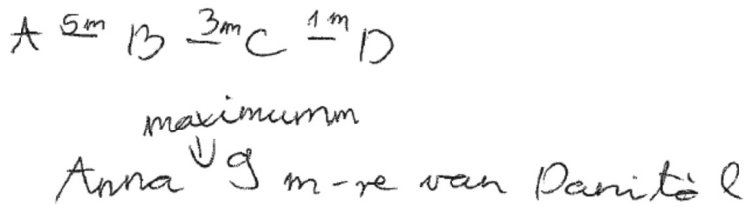

Figure 3. An example of 'EA+' reaction. The text is: 'Anna is up to 9 meters from Dani'.

- Realistic answer (RA). The pupil enumerates all the four answers either correctly or with a calculation error (Figure 4).

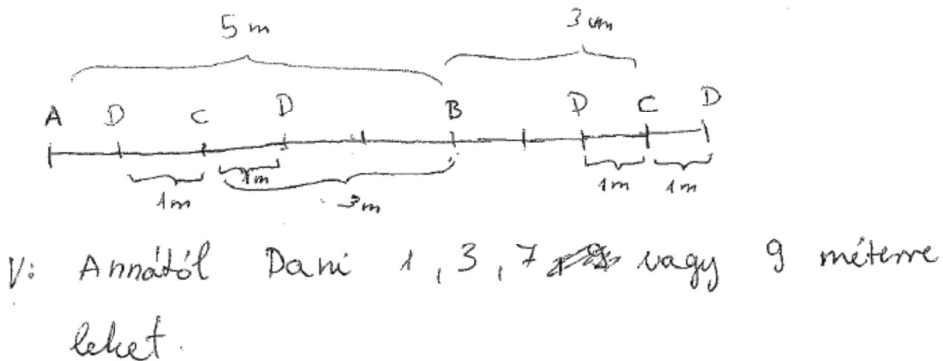

Figure 4. An example of 'RA' reaction.

- Incomplete realistic answer (RA-). We apply this code when pupil gives 2 or 3 possible answers (Figure 5).

$$5m + 3m + 1m = 9m \quad 5m - 3m + 1m = 3m$$

$$5m - 3m - 1m = 1m$$

Figure 5. An example of 'RA-' reaction.

- Other answer (OA). This category involves all answers that could not be classified into one of the former categories (Figure 6).

A	B	C	D
x-5	x	x+3	x+4

$$3x = 12$$

$$x = 4$$

Figure 6. An example of 'OA' reaction.

Verschaffel et al. (1994) use the ‘Technical error’ category in the meaning of “expected answer with technical error in the execution of the arithmetic operation(s)”. The arithmetic operations are very simple in our research, and we do not think that this aspect is decisive in our case. Moreover, every student gave a pictorial or arithmetic representation of his or her answer and we consider it primary to the final numerical result, so we do not use the ‘Technical error’ category. For instance, pupil’s drawing in clearly indicates the answer ‘7’ but the Figure 7 pupil wrote ‘8’. (This pupil listed all the four answers and we coded it as ‘RA’.)



Figure 7. Example of right pictorial representation with numerical error.

In what follows we consider RA, RA−, EA+ reactions as realistic reactions while EA and OA reactions as non-realistic reactions. We also examine the extent of elaboration of pupils’ answers in this study. The RA reaction is the fully elaborated answer while RA− and EA+ considered as partially elaborated answers (Table 2).

Table 2. The coding system in this paper.

	RA	RA−	EA	EA+	OA
realistic reaction	+	+		+	
non-realistic reaction			+		+
fully elaborated realistic reaction = RA	+				
partially elaborated realistic reaction		+		+	

4.4. The coding process

In the first phase of coding process two raters (the authors of this paper) coded the corpus entirely independently. Table 3 contains the result. The proportion of cases in which the raters agreed is $p_0 = 0.93$ (334 cases out of 359, i.e. sum of diagonal elements in the agreement matrix of proportion). The Cohen’s kappa (Cohen, 1960) is $\kappa = \frac{p_0 - p_e}{1 - p_e} = 0.89$, where $p_e = \sum_{i=1}^5 p_{i1} \cdot p_{i2}$. Both p_0 and the Cohen’s kappa value indicate high agreement. After this phase of coding process discussion on the open points took place and a consensus was reached which is used in the rest of this paper.

Table 3. The agreement matrix of proportions.

	Category	Rater (1)					
		RA	RA–	EA	EA+	OA	p_{i2}
Rater (2)	RA	0.4791	0.0056				0.4847
	RA–	0.0362	0.1532	0.0056			0.1950
	EA			0.2423	0.0139		0.2563
	EA+			0.0056	0.0418	0.0028	0.0501
	OA					0.0139	0.0139
	p_{i1}	0.5153	0.1588	0.2535	0.0557	0.0167	1.0000

After coding we collected data in contingency tables that displays the multivariate frequency distribution of variables. We used Fisher's exact test in the analysis of contingency tables (Sprenst, 2011). Fisher's exact test is a significance test independent of sample size and distribution. The usual Chi-squared test is inadequate in our research because data are very unequally distributed among the cells of the contingency tables. We executed Fisher's exact test with statistical computing program 'R' (R Core Team, 2018).

5. Results and discussion

5.1. The result of the survey

Our first research question concerns whether there is a difference between experts' and novices' regarding the recognition of the openness of the problem. Table 4 shows the frequency of students' reactions. The experts' typical reaction is RA (81.87 %) while novices' typical reaction is EA (46.89 %), see Figure 8.

Table 4. Pupils' reactions to the 'Four children' problem.

	RA	RA–	EA	EA+	OA	Total
Experts	149	19	10	4	0	182
Novices	34	41	83	13	6	177
Total	183	60	93	17	6	359

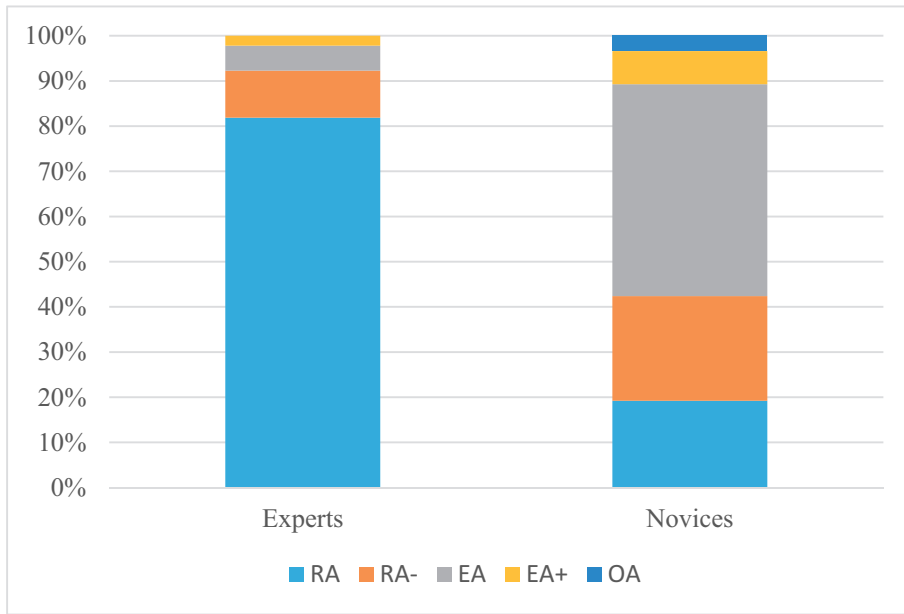

Figure 8. Pupils' reactions to the 'Four children' problem.

Fisher's exact test for Table 4 gives $p < 2.2 \cdot 10^{-16}$. This value shows that there is a significant difference between experts' and novices' reactions to the problem.

We found no significant dependence of novices' and experts' reactions on grade (Table 5 and Table 6) or geographical location (Table 7 and Table 8). These data support the sampling strategy and confirm the research design that the seventh graders and the eighth graders are in one group.

Table 5. Novices' reactions to the 'Four children' problem.

	RA	RA-	EA	EA+	OA	Total
7th graders	21	22	38	6	2	89
8th graders	13	19	45	7	4	88
Total	34	41	83	13	6	177

Fisher's exact test for Table 5 gives $p = 0.4914$. There is no reason to reject the null hypothesis i.e. the novices' reactions are independent of the age category.

Table 6. Experts' reactions to the 'Four children' problem.

	RA	RA-	EA	EA+	OA	Total
7th graders	73	11	7	2	0	93
8th graders	76	8	3	2	0	89
Total	149	19	10	4	0	182

Fisher's exact test for Table 6 gives $p = 0.5465$. There is no reason to reject the null hypothesis i.e. the experts' reactions are independent of the age category.

Table 7. Novices' reactions to the 'Four children' problem as a function of geographical location.

	RA	RA-	EA	EA+	OA	Total
Budapest	12	13	29	3	2	59
Debrecen	9	13	23	5	4	54
Miskolc	13	15	31	5	0	64
Total	34	41	83	13	6	177

Fisher's exact test for Table 7 gives $p = 0.6632$, there is no reason to reject the null hypothesis, i.e. novices' reactions are independent of the geographical locations.

Table 8. Experts' reactions to the 'Four children' problem as a function of geographical location.

	RA	RA-	EA	EA+	OA	Total
Budapest	46	5	3	1	0	55
Debrecen	53	6	3	1	0	63
Miskolc	50	8	4	2	0	64
Total	149	19	10	4	0	182

Fisher's exact test for Table 8 gives $p = 0.9828$, there is no reason to reject the null hypothesis, i.e. experts' reactions are independent of the geographical locations. Significant differences between the response of novices and experts are also present when examining the relative proportions of all realistic reactions: 94.51 % versus 49.72 %, see Table 9.

Table 9. Realistic (RA or RA- or EA+) and non-realistic (EA, OA) reactions to the 'Four children' problem.

	Realistic	Non-realistic	Total
Experts	172	10	182
Novices	88	89	177
Total	260	99	359

Fisher's exact test for Table 9 gives $p < 2.2 \cdot 10^{-16}$. This value shows that there is a significant difference between experts' and novices' reactions to the problem (Figure 9).

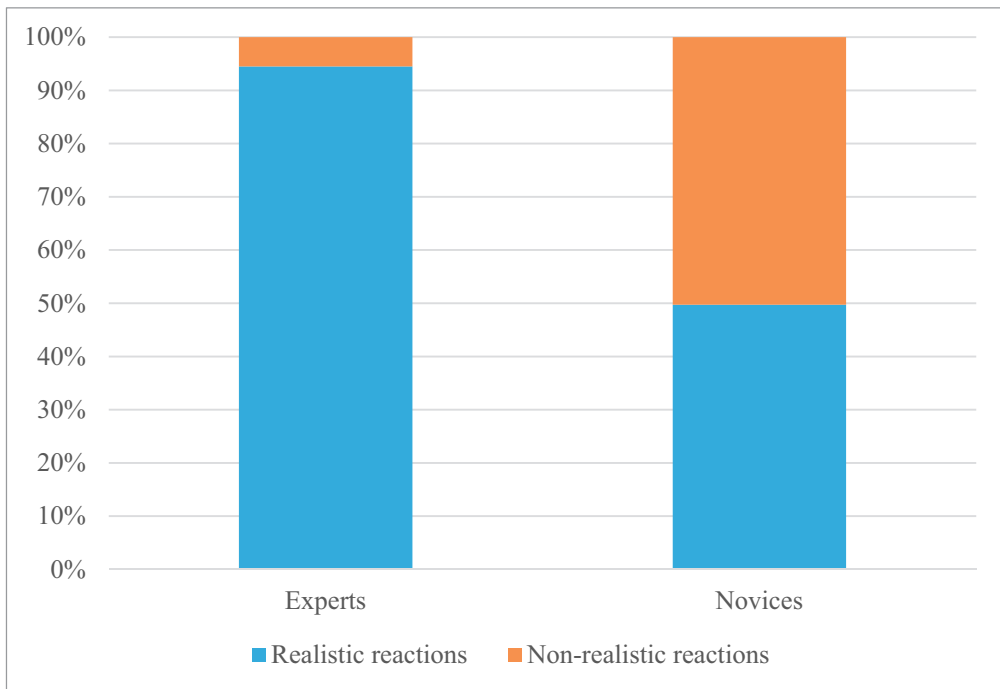

Figure 9. Realistic (RA or RA– or EA+) and non-realistic (EA, OA) reactions to the ‘Four children’ problem.

Our second research question concerns whether there is a difference between experts’ and novices’ regarding the quality of the elaboration of the answer. 86.63 % of experts’ realistic reactions is fully elaborated (i.e. it is an RA reaction) on the counterpart, only 38.64 % of novices’ realistic reactions is complete, see Table 10.

Table 10. Fully elaborated (RA) and partially elaborated (RA– or EA+) realistic answers for the ‘Four children’ problem.

	Fully elaborated	Partially elaborated	Total
Experts	149	23	172
Novices	34	54	88
Total	183	77	260

Fisher’s exact test for Table 10 gives $p = 3.457 \cdot 10^{-15}$. The experts elaborate the answer significantly better than novices (Figure 10).

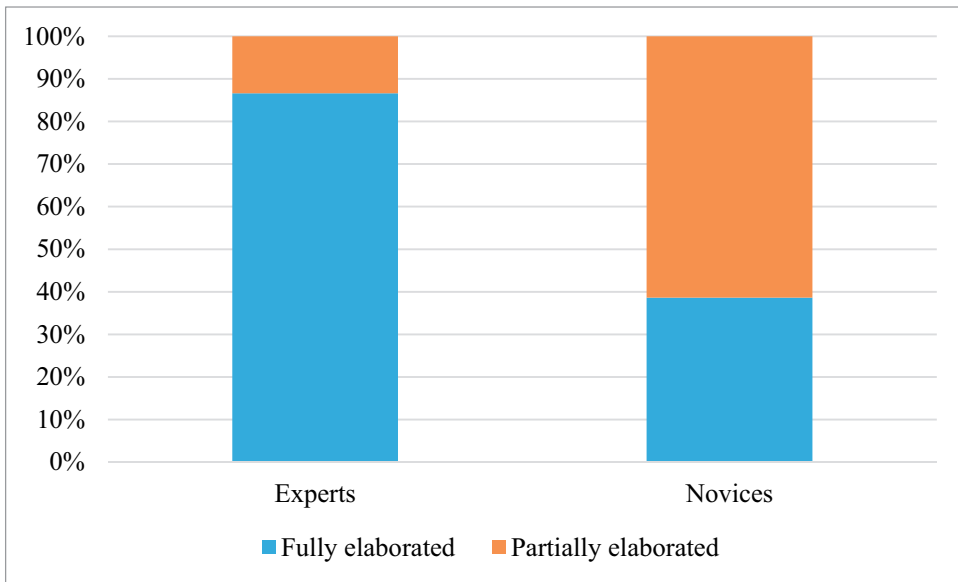

Figure 10. Fully elaborated (RA) and partially elaborated (RA– or EA+) realistic answers for the ‘Four children’ problem.

We didn’t find any significant dependence on geographical location or grade in this research question either.

6. Conclusion

In this study, we refine the overall verdict, i.e. students, regardless from their age; have difficulties with recognition of the realistic content and openness of mathematical tasks. Our hypothesis was that there are considerable differences between the results of beginners and advanced problem solvers in the fine structure of generally poor results. Moreover, in terms of success, expert-novice differences are not caused primarily by age, but by special training in mathematical problem solving. Now we summarize our results related to the research questions.

Q1: Are there any differences regarding the recognition of the openness of mathematical problems between experts and novices?

We found that there is a difference between experts’ and novices’ reactions to the open problem of the survey. Experts’ and novices answer patterns differed significantly as did the dominant answers of the two groups, that is the realistic answers by experts and the expected answers by novices. Experts gave significantly more realistic reactions than novices.

Q2: Are there any differences regarding the quality of elaboration of solution between experts and novices who recognize the openness of a problem?

The experts elaborate the answers significantly better than novices.

Based on these findings we argue that general problem-solving training could help to recognize the openness and the realistic content of a problem and to elaborate it correctly without any aimed intervention on the field of open problems.

Acknowledgements

This research was supported by the Content Pedagogy Research Program of the Hungarian Academy of Sciences (MTA-ELTE Complex Mathematics Education Research Group).

We would like to thank to Szilvia Tóth (student at the University of Nyíregyháza), who took part in the implementation and evaluation of the preliminary survey.

References

- [1] AMBRUS, G., HERENDINÉ KÓNYA, E., KOVÁCS, Z., SZITÁNYI, J., & CSÍKOS, C. (2019). A cross-sectional analysis of students' answers to a realistic word problem from grade 2 to 10. *International Electronic Journal of Mathematics Education*, 14(3), pp. 513–521, <https://doi.org/10.29333/iejme/5753>.
- [2] COHEN, J. (1960). A Coefficient of Agreement for Nominal Scales. *Educational and Psychological Measurement*, 37–46. doi:10.1177/001316446002000104.
- [3] LEITHWOOD, K., & STEINBACH, R. (1995). *Expert Problem Solving: Evidence from School and District Leaders*. Albany: SUNY Press.
- [4] PEHKONEN, E. (1997). Introduction to the concept of “open-ended problem”. in E. Pehkonen (Ed.), *Use of open-ended problems in mathematics classroom* (pp. 7–13), Helsinki: University of Helsinki.
- [5] R CORE TEAM (2018). *R: A language and environment for statistical computing*. Vienna, Austria: R Foundation for Statistical Computing. Retrieved from www.R-project.org.
- [6] SCHOENFELD, A., & HERRMANN, D. (1982). Problem Perception and Knowledge Structure in Expert and Novice Mathematical Problem Solvers. *Journal of Experimental Psychology: Learning, Memory, and Cognition*, 484–494.
- [7] SPRENT, P. (2011). Fisher Exact Test. in M. Lovric, *International Encyclopedia of Statistical Science* (pp. 524–525), Berlin, Heidelberg: Springer Berlin Heidelberg.
- [8] SWELLER, J., MAWER, R., & WARD, M. (1983). Development of Expertise in Mathematical Problem Solving. *Journal of Experimental Psychology: General*, 639–661.
- [9] VERSCHAFFEL, L., DE CORTE, E., & LASURE, S. (1994). Realistic considerations in mathematical modeling of school arithmetic word problems. *Learning and Instruction*, 273–294.

Appendix

The ‘Four children’ problem was set in a local mathematics competition in 2018 in Nyíregyháza, Hungary for 5th graders. 28 pupils participated in the competition from agglomeration of Nyíregyháza and these pupils are considered as experts in the preliminary survey. The problem was also written by 57 5th grade students from an average school in Debrecen, Hungary and these pupils are considered as novices. During the preliminary survey, we tested the problem setting, the time needed to solve the problem, and the coding system. We found that the coding system is suitable to describe the corpus and in the school survey 10 minutes is enough to handle the problem.

The detailed result of the preliminary study is in Table 11.

Table 11. 5th graders reactions to the ‘Four children’ problem in the preliminary survey.

	RA	RA–	EA	EA+	OA	Total
Experts	5	5	16	2	0	28
Novices	3	2	49	0	3	57
Total	8	7	65	2	3	85

Fisher’s exact test for Table 11 gives $p = 0.00204$. This value shows that there is a significant difference between experts’ and novices’ reactions to the problem. Moreover, we found that 8.77 % of novices and 42.86 % of experts gave realistic reaction (Table 12).

Table 12. Realistic (RA or RA– or EA+) and non-realistic (EA, OA) reactions to the ‘Four children’ problem in the preliminary survey.

	Realistic	Non-realistic	Total
Experts	12	16	28
Novices	5	52	57
Total	17	68	85

Fisher’s exact test for Table 12 gives $p = 0.0004$. This value shows that there is a significant difference between experts’ and novices’ reactions to the problem. However, we did not find significant difference between extents of elaboration of the answer (Table 13).

Table 13. Fully elaborated (RA) and partially elaborated (RA– or EA+) realistic answers for the ‘Four children’ problem in the preliminary survey.

	Fully elaborated	Partially elaborated	Total
Experts	5	7	12
Novices	3	2	5
Total	8	9	17

Fisher’s exact test for Table 13 gives $p = 0.6199$. There is no reason to reject the null hypothesis (i.e. the extent of elaboration is independent of expert-novice

category) based on the preliminary survey and more data needed to study this correlation.

Contact addresses:

Zoltán Kovács
Institute for Mathematics and Computer Science
University of Nyíregyháza
Sóstói út 31/b, Nyíregyháza, Hungary
e-mail: kovacs.zoltan@nye.hu

Eszter Kónya
Institute for Mathematics
University of Debrecen
Egyetem tér 1. Debrecen, Hungary
e-mail: eszter.konya@science.unideb.hu

Hogyan közelítenek meg egy nyitott problémát a kezdők és a szakértők?

Kovács Zoltán¹ és Kónya Eszter²

¹Nyíregyházi Egyetem, Matematika és Informatika Intézet, Nyíregyháza, Hungary

²Debreceni Egyetem, Matematika Intézet, Debrecen, Hungary

Kivonat. A kezdők és a szakértők problémamegoldó kompetenciái között jól ismertek a különbségek. Az irodalomból is ismert, hogy a tanulók az életkortól függetlenül jellemzően az elvárt választ adják, figyelmen kívül hagyva a probléma nyitottságát. Vizsgálatunkban egy olyan problémát tűztünk ki, amely a kiindulási ponton nyitott, de zárt megoldása van. Elemezzük, hogy 7. és 8. osztályos, kezdőknek, illetve szakértőknek számító tanulók hogyan reagálnak a probléma nyitottságára.

Kulcsszavak: nyitott problémák, realiztikus reakció, kezdő és szakértő problémamegoldó

Preservice mathematics teachers and teacher research

Sanja Rukavina

Department of Mathematics, University of Rijeka

Abstract. Teacher research is intentional and systematic inquiry carried out by teachers. Mainly, it is recognized as an effective way of improving everyday classroom practice, but it can also be a starting point for a systematic investigation of a wider problem. Furthermore, recent changes in the Croatian Education System recognize the importance of the role of a teacher as an active participant in the changing of the educational process. The School for Life program needs teachers willing to conduct teacher research and to take initiative and responsibility in the shaping of the “school for life”. Which problems can be expected during that process? Are preservice mathematics teachers prepared for that challenge? Which changes in their education are needed? These questions will be discussed based on the findings collected from the students of the graduate teacher training courses at the Department of Mathematics, University of Rijeka.

Keywords: teacher research, preservice teacher, role of the teacher, mathematics teaching, School for Life

1. Introduction and preliminaries

The question of the importance and the quality of the research in the teaching-learning process designed and implemented by teachers is not new. Discussions on the subject emphasize the importance of research on the issues that are detected as significant by the teachers themselves, and the fact that teacher research should be considered as its own genre, not entirely different from other types of systematic inquiry into teaching, yet with some quite distinctive features (Cochran-Smith and Lytle, 1990). Teacher research is a non-quantitative (non-psychometric, non-experimental) research in which as a leading researcher appears the teacher in whose class the research is conducted. The research carried out by teachers has a dual purpose, on the one hand enhancing teacher’s sense of professional role and identity, and on the other hand contributing to the quality of the teaching and learning process in classrooms (Lankshear and Knobel, 2004). Such a research provided

us with new insights into the process of teaching and learning: it paid much closer attention to details and practicalities than other kinds of research (Altrichter, Posch and Somekh, 1993).

The major consequence of doing their own research is that teachers take more control of their professional lives (Downey-Skochdopole and French, 2012). Teachers' ability to conduct an action research in the classroom will certainly contribute to the quality of their teaching. Therefore, their professional development should include education on the methods that can be used to self-assess and improve their own practice. One of examples of such training activities is presented in the publication *Action Research for the Professional Development of Teachers* (2011) published by Education and Teacher Training Agency, consisting of contributions from scientists and teachers attending one of the workshops.

Recent changes in the Croatian Education System emphasize the importance of the role of a teacher as an active participant in the improving of the teaching process. The School for Life program needs teachers willing to conduct teacher research and to take initiative and responsibility in the shaping of the "school for life" (Škola za život, 2019). That again raises the questions, that we have already discussed (Rukavina, 2012): Are preservice mathematics teachers prepared for that challenge? Which changes in their education are needed? These questions will be discussed based on the findings collected from the students of the graduate teacher training courses at the Department of Mathematics, University of Rijeka.

The Department of Mathematics of the University of Rijeka organizes and conducts two teacher training programmes: Graduate Course in Mathematics and Graduate Course in Mathematics and Computer Science. The study programme Graduate Course in Mathematics contains an obligatory course Selected topics from teaching mathematics whose part deals with the methodology of research in the field of mathematics education. The students enrolled in the study programme Graduate Course in Mathematics and Computer Science are informed on the research methodology only to the extent necessary to carry out small-scale research to produce more demanding homework or seminars and, in some cases, in the graduation thesis work. They can enroll Selected topics from teaching mathematics as an elective course.

Since academic year 2017/2018, the Department of Mathematics of the University of Rijeka organizes part-time teacher training programme Graduate Course in Mathematics. In the context of the introductory considerations, as a continuation of our previous work, we wanted to find out how the part-time students that passed a course dealing with methodology of research in education react to such course. In other words, we try to find out if they recognize that such course is important part of their education and future work.

2. Preservice teachers' research

The elective course Selected topics from teaching mathematics was enrolled in 2011/2012 by five students of the final semester of the preservice teacher training programme (Rukavina, 2012). The students were assigned the task of conducting

research related to the topic they think is relevant for teaching mathematics. Since the intention was to examine to which extent they were able to independently investigate, students were not given precise instructions on how to collect data or analyze them. However, in the preparatory stage, the students had to analyze an article related to the mathematics education by their own choice (Kovarík, 2010, Muir, 2012, Šapkova, 2011, Watson, 2010, Yara, 2009). Presentations of selected articles were made in the form of seminars in front of the members of the group. The students were also familiar with the result of a similar assignment, which was performed by their colleagues who were more intensively guided and supervised by the professor, especially in the stage of interpretation of the results (Rukavina, Kovačević and Bakić, 2011). Through these preparatory activities, students learned about several possible ways of conducting research, interpretation and presentation of their results, but lacked instructions on how to conduct research and interpret the collected data. It was assumed that teachers in a similar situation will do the same prior to conducting the research – study several articles by their own choice in order to get acquainted with the possible ways of conducting and presenting the research, and then, without theoretical background on the research methodology, conduct a research.

Three students' studies were obtained as a result of the assignment. Students named their research as follows: Examination of the quality of the private tutoring in mathematics, Use of teaching resources in the mathematics teaching and Mathematical personality of pupils. Since the analysis of these students' studies was referred at a conference (Rukavina, 2012), but never published, we present here a few examples from these studies in order to point out the most common mistakes.

2.1. Example 1: Examination of the quality of the private tutoring in mathematics

In the introductory part of the research entitled Examination of the quality of the private tutoring in mathematics, it is stated "... we wanted to check some basic information regarding the private tutoring and to check the opinions of the students about their quality. We wanted to see if the students feel safe during the private tutoring or during the regular classroom ...". The survey was conducted through questionnaires / inquiry forms on a sample of 110 high school students, mostly in grammar schools. In addition to the basic data (gender, grade, type of the school, programme, grades in mathematics), pupils responded to 16 questions which, according to the questionnaire authors, needed to collect general information about the private tutoring, to determine the difference between tutoring in private teaching centers and private tutoring provided by individuals, and to examine what pupils suggest in order to improve the quality of tutoring. No data was collected from pupils who stated that they did not go to the private tutoring. The students conducting the research did not even write down the number of such pupils and did not know whether their number was bigger or smaller than the number of those who were interviewed. Furthermore, in the first part of the study, an analysis of the structure of the respondents was carried out. For example, from the collected data, the following conclusion was derived: "... we can see that the private tutoring is most attended mainly by students who had a grade "sufficient" (33.98 %), followed by students with grade "good" (29.13 %). Students with the grades "insufficient"

and “very good” attend instruction to the same extent (15.53 %) ... ”. This conclusion can be misunderstood as it was not explored how many students in the whole population have a certain grade. It is possible that the obtained “private tutoring attendance” distribution coincide with the distribution of the grades in mathematics in the entire population and then such a conclusion would not be valid. The additional data needed to make such a conclusion can be collected from the available statistical data or by collecting data from the pupils who stated that they did not attend the private tutoring but this was not done as a part of a research.

2.2. Example 2: Use of teaching resources in teaching mathematics

The second preservice teachers’ research was entitled Use of teaching resources in teaching mathematics. According to the author, this is a study with the scope to determine how much teaching resources are used in the teaching of mathematics. The survey was conducted on a sample of 181 high school students and 164 responses were taken into account for the analysis of results. In the introductory text of this research, the teaching materials and tools are defined and described extensively, whereby the questions are asked partly in contradiction with the title of the research, precisely because of the inadequate differentiation of these terms. The data on the structure of the respondents were also collected, and many of them were not sufficiently used in the later analysis of the answers. In the analysis of the results of this research, the fact-based narrative of the collected data is noticed with the rare attempts to interpret them or to investigate the relationship between the answers to different questions. As an example, we list the data showing the answers to the two questions asked (Tables 1 and 2).

Table 1. The way in which your mathematics teacher present the content is

Quality of the presented content	Relative frequency (%)
boring	29
interesting	27
I cannot tell.	43

Table 2. Which of the following tools are used by your teacher?
(Multiple answers are allowed.)

Teaching resource	Relative frequency (%)
Geometric tools	51
Computer and projector	19
Internet	1
A board	1
Nothing	16
Something else	12

It would be interesting to determine whether the use of teaching resources and students’ perception of the lessons (interesting / boring) are related, but that

connection has not been explored. Also, we notice that in the second question the possibility of rounding up more responses has been left and it is assumed that some students have done so. By summarizing the above percentages, one can conclude that each student selected only one answer. Since there is no comment on this issue, it remains unclear whether all the students have selected only one answer or an error in the presentation of the results was made.

2.3. Example 3: Mathematical personality of pupils

The third research was entitled *Mathematical personality of pupils*, and according to the announcement of the author the goal of the "... research is to find out to what extent one of the three types of mathematical personality prevails among high school students." and to "... examine whether the mathematical personality influence on the success in adopting mathematics teaching content." The three types of the mathematics learning personality were considered depending on how students process mathematics information and make sense of received mathematics information (Sharma, 2001). Good understanding of the conceptual part of mathematics (processes and structures as a whole) was characterized as qualitative personality, and students strong in the procedural part of mathematics were characterized as persons with quantitative personality. Of course, a majority of students have characteristics of both types and belong to the combined type.

The research was conducted in three secondary schools (two grammar schools and one vocational school) on a sample of 402 respondents. In this study the collected data on respondents' personal characteristic were used for further analysis. For example, the share of respondents with a certain type of mathematics learning personality with regard to the grammar school course they are attending was considered. Of course, here too, a more detailed analysis of the correlation of the responses to the different questions could be done (for example, considering the students that attend a particular grammar school with regard to their gender, etc.). Nevertheless, this student research yields results that can be compared to the results of other research. The greatest disadvantage of this research lies in the fact that it is not explained how respondents, depending on the answers to the given questions, are classified into the category of persons with qualitative, quantitative or combined mathematical personality type. Instead of that, reference is made to the relevant literature (Sharma, 2001), assuming that all readers will in the same way interpret the relation between the questions asked in the study and the relevant type of mathematical personality.

3. Part-time students' responds

Since academic year 2017/2018, the Department of Mathematics of the University of Rijeka organizes part-time preservice teacher training programme Graduate Course in Mathematics. Among the students that enrolled that study programme in the academic year 2018/2019, there are seven students that have passed the course

Methodology of the research in education at some other university. Because of the lack of mathematics teachers in Croatian schools, all of them are employed and work in elementary school as a replacement, mainly for the last few years. One of them works as a replacement almost 30 years. Our plan was to collect as much as possible information on their knowledge regarding action research and to find out what questions they or their colleagues investigate when they conduct such research. It turns out that interviews were very short, because the responds of the part-time students were almost the same and can be summarized as follows.

- They did pass the course Methodology of the research in education, but the research that they conducted within that course was “just some small questionnaire, nothing serious”.
- They did not conduct any research in the school. They do not have plan to do that soon.
- As far as they know, their colleagues do not conduct any teacher research.

It is obviously that these students did not take seriously the course on the methodology of the research. The fact that they do not conduct any research is partially expected because all of them work as replacements, they do not expect to work in the same school for a long period and, therefore, they are not interested for advancing their teaching at the current position. However, teacher research can be used to improve quality of the teaching during one year and it is not entirely justified to have such an attitude. The part-time students did not have an answer to the question what do they think why their colleagues do not use action research for improving the quality of their teaching. They were very confident in their answers and the question “Is it possible that your colleagues conduct research, but you are not aware of that because you think of such a research in the terms of “just some small questionnaire”?” did not cause a change of their statements. This is in line with results of studies which emphasize that teachers admit to conducting no research at all, since they believe that lesson observations, keeping journals, and similar activities cannot be considered to be “real” research (Pesti, Gyori and Kopp, 2018).

4. Conclusion

According to the Eurydice 2011 survey, 39.4 % of preservice mathematics teachers in Europe get acquainted with the methodology of the research in education through the assignments they have to perform in order to pass some course, and 18.1 % of them are not familiar with it (Eurydice, 2011). Students of the Department of Mathematics of the University of Rijeka, depending on the tasks assigned to each generation and the elective courses enrolled, can be counted in one of these two groups. Not surprisingly, they make a number of mistakes when trying to conduct independent research and interpreting the collected data. Further, according to the responds of the part-time students, a part of the preservice teachers does not take seriously the course on the methodology of the research in the cases when such a course is delivered. Also, it cannot be expected that the senior teachers

will help them to conduct their first action research in the school. It is necessary to develop future teachers' specific competences by better integration of research into teacher training education programmes. Being sensitised regarding teacher research, preservice teachers will enter the world of work with the ability to transform their everyday, classroom practices with the aim of recognizing and reacting to the newly emerging challenges and needs (Pesti et al., 2018).

Furthermore, at the moment, a large number of teachers is educated to be able to work in line with the School for Life reform programme. One of the objectives of that programme is a creative teacher with more autonomy. Our findings show that, in order to achieve the set goals of the reform, this education must contain additional content on the teacher research. For beginning teachers, such research inclusive training will offer the opportunity for transition into the role of teacher-researcher (Gray and Campbell-Evans, 2002).

References

- [1] MIĆANOVIĆ, M. (Ed.) (2011). *Akcijsko istraživanje i profesionalni razvoj učitelja i nastavnika*. AZOO, Zagreb.
- [2] ALTRICHTER, H., POSCH, P., SOMEKH, B. (1993). *Teachers Investigate Their Work: An Introduction to the Methods of Action Research across the Professions*. London and New York: Routledge.
- [3] COCHRAN-SMITH, M., LYTLE, S.L. (1990). Research on Teaching and Teachers Research: The Issues That Divides. *Educational Researcher*, 19(2), 2–11.
- [4] DOWNEY-SKOCHDOPOLE, L., FRENCH, M. J. (2012). Textbook analyses: preservice elementary teachers' debuts in the role of teacher as researcher. *Journal of Elementary Science Education*, 12(1), 1–17.
- [5] Eurydice (2011). *Mathematics Education in Europe: Common Challenges and National Policies*. Eurydice, Brussel.
- [6] GRAY, J., CAMPBELL-EVANS, G. (2002). Beginning Teachers as Teacher-Researchers. *Australian Journal of Teacher Education*, 27(1), Article 4. Retrieved March 15, 2019 from <https://ro.ecu.edu.au/ajte/vol27/iss1/4/>
- [7] KOVARIK, M. (2010). Building Mathematics Vocabulary. *International Journal for Mathematics Teaching and Learning*. Retrieved March 15, 2019 from <http://www.cimt.org.uk/journal/kovarik.pdf>
- [8] LANKSHEAR, C., KNOBEL, M. (2004). *A Handbook for Teacher Research*. Maidenhead: Open University Press.
- [9] MUIR, T. (2012). Numeracy at Home: Involving Parents in Mathematics Education. *International Journal for Mathematics Teaching and Learning*, (25 January 2012), 1–13. Retrieved March 15, 2019 from <http://ecite.utas.edu.au/77452>
- [10] PESTI, C., GYORI, J. G., KOPP, E. (2018). Student Teachers as Future Researchers: How do Hungarian and Austrian Initial Teacher Education Systems Address the issue of Teachers as Researchers? *CEPS Journal*, 8(3), 35–57.

- [11] RUKAVINA, S. (2012). Budući nastavnici matematike kao potencijalni istraživači nastavnog procesa. *Program i sažeci 1. Dani obrazovnih znanosti "Kvaliteta obrazovanja – istraživačke perspektive"*, Institut za društvena istraživanja, Zagreb, 51.
- [12] RUKAVINA, S., KOVAČEVIĆ, D., BAKIĆ, M. (2011). Why is there a shortage of mathematics teachers? The high-school students' views on the mathematics teacher profession. in Pavleković, M. (Ed.), *International scientific colloquium Mathematics and Children: The Math Teacher*, pp. 9–19, Element.
- [13] SHARMA, M.C. (2001). *Matematika bez suza*. Posokhova, I. (ed.), Ostvarenje d.o.o.
- [14] ŠAPKOVA, A. (2011). Latvian Mathematics Teachers' Beliefs on Effective Teaching. *International Journal for Mathematics Teaching and Learning*. Retrieved November 28, 2011 from <http://www.cimt.plymouth.ac.uk/journal/shapkova.pdf>
- [15] Škola za život – Program (2019). Retrieved March 15, 2019 from <https://skolazazivot.hr/>
- [16] WATSON, A. (2010). Shifts of mathematical thinking in adolescence. *Research in Mathematics Education*, 12(2), 133–148.
- [17] YARA, P.O. (2009). Students Attitude Towards Mathematics and Academic Achievement in Some Selected Secondary Schools in Southwestern Nigeria. *European Journal of Scientific Research*, 36(3), 336–341.

Contact address:

Sanja Rukavina
Department of Mathematics
University of Rijeka
Radmile Matejčić 2, 51000 Rijeka, Croatia
e-mail: sanjar@math.uniri.hr

Budući nastavnici matematike i istraživanje u nastavi

Sanja Rukavina

Odjel za matematiku, Sveučilište u Rijeci, Rijeka, Hrvatska

Sažetak. Nastavničko istraživanje je akcijsko istraživanje usmjereno prvenstveno na poboljšanje vlastite prakse, a može poslužiti kao polazna točka za sustavno istraživanje većeg problema uočenog u nastavnoj praksi. Nedavne promjene u hrvatskom obrazovnom sustavu prepoznaju značaj uloge nastavnika kao aktivnog sudionika i kreatora obrazovnog procesa. Za uspješnu realizaciju programa Škola za život potrebni su nastavnici koji će provoditi istraživanja u nastavi i preuzeti inicijativu i odgovornost za oblikovanje “škole za život”. Koji se problemi mogu očekivati tijekom tog procesa? Jesu li budući nastavnici matematike spremni za taj izazov? Koje su promjene u njihovom obrazovanju potrebne? O ovim ćemo pitanjima raspravljati na temelju saznanja dobivenih od studenata diplomskih studija nastavničkog smjera Odjela za matematiku Sveučilišta u Rijeci.

Cljučne riječi: matematičke kompetencije, akcijsko istraživanje, budući nastavnici, uloga nastavnika, nastava matematike, Škola za život

Mathematical problem solving in practice

Edith Debrenti¹ and Balázs Vértessy²

¹Faculty of Economics and Social Sciences, Partium Christian University, Oradea, Romania

² Institute of Mathematics, University of Debrecen, Hungary

Abstract. In elementary education, in the course of solving word problems, we can use multiple methodologies like visualization, fake perception, reversed way (backward induction), comprehension, elimination, evaluation, integration and scale method.

We have a problem, if there is a goal, a task to be solved, but we do not know the way to achieve it, we are facing an obstacle. The way to overcome the obstacle is the problem solving process. The search for and elaboration of the solution is called problem solving. Problem solving thinking is influenced by several factors: precognition, strategies, metacognitive skills, conviction, attitudes as well as self-management.

Problem solving depends on how you manage to mobilize your existing knowledge, the ability to engage in active analysis, the reflectiveness and the creative attitude.

We surveyed 4th graders (10 years old pupils) and student teachers with a test in which we collected exercises which can be solved with different methodologies. It is an exploratory study, with participants from two countries: Hungary and Romania. We were investigating the participants' flexible thinking, the knowledge and diversity of their problem solving skills as well as their accuracy and the most common problems which occurred in the test.

Keywords: knowledge, problem-solving skills, unusual problems, heuristics, strategies

1. Introduction

“If I had to prioritize in order of importance what makes somebody like mathematics: a good goal, a good method or a good teacher, I would put the teacher first... A good teacher should be a master of their subject, they should love teaching, but before all they should have sufficient spiritual strength, culture and psychological insight to put the problem at the centre of teaching, not their own person, to let pupils explore, and discover on their own, and be genuinely happy when somebody finds the solution without their help, or with their unnoticed help”.

(George Pólya)

One of the most important tasks of teaching Mathematics in schools is to help in accomplishing the culture of general thinking by further developing mathematical thinking.

Problem solving plays an important role in the development of creative thinking: problem solving encompasses the process of recognizing, understanding, describing, solving and verifying a problem, as well as generalizing the solutions (Tuzson, 2003).

What is a problem? “We commonly speak of a problem when the attainment of a goal is impeded. The course of overcoming the impediment is the problem-solving process, the purposeful reasoning” (Pintér, 2012, 9).

Problem-solving strategies and cognitive operations should be taught knowingly. Gifted pupils can get the essence of the problems on their own, only after a few examples and can use the main ideas for future problems. Average or weaker pupils fail to do this. They need heuristic structures, a clear awareness and acquisition of cognitive operations. In most cases the focus is on the problem-solving process, not on the solution. The structure of this process has to be reiterated (Ambrus, 2002).

Researchers found that pupils learn more in classrooms if consistently work on tasks with a high level of cognitive demand (Henningsen and Stein, 1997).

The tasks teachers pose in their classrooms deserve important consideration because they open or close the pupils’ opportunity for meaningful mathematics learning. They convey implicit messages about the nature of mathematics: what it is, what it entails, and what is worth knowing and doing in mathematics. Mathematical tasks, the NCTM (1991) proposes, are not to be chosen lightly – because they are fun or suggested in textbooks. Instead, tasks should be chosen because they have the potential to “engage pupils’ intellect,” “can be approached in more than one interesting way,” and “stimulate pupils to make connections and develop a coherent framework for mathematical ideas” (NCTM, 1991, p. 25). The NCTM (2000) for instance suggests that tasks that require pupils to apply a known procedure to reach an expected answer differ significantly from tasks that require pupils to reason, communicate, represent, problem solve, and make mathematical connections. (Crespo, 2003, 244).

Problems can be classified into routine and non-routine problems, as well as standard and non-standard problems (Olkun et al 2009).

Pupils have to employ a flexible and practical way of thinking when they are faced with problems they have never experienced before (PISA, 2005). According to Pólya (2000) solving routine problems does not contribute to pupils' cognitive development. He considers that more difficult problems provide opportunities for pupils to develop higher-order thinking skills, in the process of understanding, analysing, exploring and applying mathematical concepts. Non-routine problems provide real-life situations which are more challenging in terms of thinking skills, including critical and creative thinking.

Pólya (2000) describes four steps of problem solving:

1. Understanding the problem, focusing and organizing data: pupils understand the problem only if they can define the data, the unknown and the conditions.
2. Analysing the problem and making a problem solving plan: translating to the language of mathematics, which results in a mathematical model.
3. Carrying out the plan: it depends on the mathematical model.
4. Verifying the solution, checking if conditions are satisfied: if the solution turns out to be incorrect and we figure out what went wrong we will be able to correctly solve the problem many times.

Learning problem-solving strategies has an important role already in elementary education. Children consider the problem a practical difficulty for which they try to find a solution and by doing this they gain new knowledge and experiences. The problem-solving process is in fact the path leading to the solution.

In the curriculum for elementary education we can distinguish the following problem-solving strategies:

1. Using different representations (number line, drawing, figure, representation with segments, sets, graphs, tables)
2. Backward induction
3. Rephrasing the problem
4. Looking for patterns
5. False assumption method
6. Reduce to less variables, then use the solution
7. Algorithmic thinking
8. Equation and inequality problems
9. Other strategies

Emphasis should be laid on the steps of solving problem type word problems, on models for problem solving and on verifying solutions.

According to the curriculum pupils should be familiarized with different problem solving methods, which they should understand and be able to use for other problems and the pupils themselves should create word problems.

4th and 5th graders often use guessing and the intelligent trial and error method for problem solving. They very rarely try to solve the problem in a particular way, they seldom use backward induction or representation (Yazgan, Bintas 2005).

7th and 8th graders are successful in systemizing data, drawing and backward induction (Altun, Arslan 2006).

To develop efficient thinking in pupils, elementary teachers should also be familiar with and use the problem-solving strategies enumerated above, as well as the problem-solving steps and models.

Various international assessments (TIMSS, PISA) and researches prove that the teacher's knowledge and teaching method are the two most important factors influencing pupils' achievements in mathematics (An et al, 2004). The better problem solving skills the teacher has, the more efficient he/she can be in teaching different strategies, and creating new problems. An old Chinese proverb says if you want to give your pupils a glass of water, you need to have a bucket of water (Ünlü, 2018).

While teaching didactics and pedagogy of mathematics we have found that a wide range of features is available as regards pupils' mathematical knowledge and mathematical thinking. A large number of pupils have difficulty in understanding problems. Pupils who do understand the problems often employ learned patterns (formulas, algorithms), which they do not use accurately.

We have placed great importance on developing problem-solving skills in all aspects of the training. In order to achieve this, pupils have to deal with word problems that are unfamiliar to them and for which they themselves have to find the steps, the algorithm.

On a general level, problem solving skills and the familiarity with heuristic techniques and their level of application among university students shows significant differences (Apostol, 2017).

There are very few researches investigating the problem solving thinking of prospective mathematics teachers. Ünlü (2018) investigated the problem solving skills of prospective mathematics teachers and concluded that students have limited skills at the stage of understanding the problem, or planning the solution. They do not understand the task; consequently, they cannot choose an appropriate strategy.

It is important that students develop their problem solving skills, and in order to do this they should encounter a number of unconventional, non-routine and non-standard problems (Olkun et al 2009).

2. The aim of the research

Our priority was to reveal the strengths and weaknesses of participants' basic mathematical knowledge, ways of thinking and strategies used for solving unconventional problems.

We have also investigated the most and less successfully used *topics* (content areas) and *problem-solving strategies* employed by the group under scrutiny.

In the present research we made use of a test consisting of 14 word problems which could be solved if interpreted and understood correctly. The test contains *a selection of unconventional problem, which require different solving methods*. This makes the problems appropriate for investigating practical knowledge.

Research participants had to solve problems with a higher level of difficulty designed for 4th grade pupils. In their answers we have focused on the methods used and the diversity of these. We have also analysed the most common mistakes.

We have looked into the most frequently used problem solving methods by 4th graders as well as teacher training students.

Our exploratory research presents the two samples separately.

3. Participants, methodology

The research participants were students specializing in Pedagogy of Primary and Preschool Education: 47 students from Partium Christian University (Romania), 19 students from Babeş–Bolyai University (Romania), 27 students from the University of Nyíregyháza (Hungary), and 13 students from the School-teacher programme at Debrecen Reformed Theological University (Hungary). Other participants were 44 4th grade pupils at the Reformed Practice Primary School “Ferenc Kölcsey” Debrecen (Hungary), and 56 pupils from two primary schools in Oradea (Romania). Altogether $N = 47 + 19 + 27 + 13 + 44 + 56 = 206$ participants. We have analysed the two samples separately in our research.

The 206 participants had to solve the problems in the test designed by us in the 2018/19 academic year. Our focus was on the accuracy of the answers provided, the problem-solving methods used and the diversity of these methods.

Participants were given 60 minutes to complete the test with 14 problems and were not allowed to use any resources. We have selected problems from the Zrínyi Ilona Mathematics Competition and the Kangaroo Mathematics Contest.

The problems belong to the following five content areas:

1. Within sets, logic: truth value of statements, negation of statements;
2. Within arithmetic, algebra: number concept, numerical neighbours, rounding, operations, counting methods, fractions;
3. Within geometry, measurements: use of units, perimeter, area, shapes;
4. Within relations, functions, sequences: open sentences, direct proportion, sequences;
5. Within combinatorics, probability: permutation.

The following problem-solving strategies had to be used to solve the problems:

1. representation method
2. false assumption method
3. backward induction
4. comparing and contrasting method
5. using algebra, equations

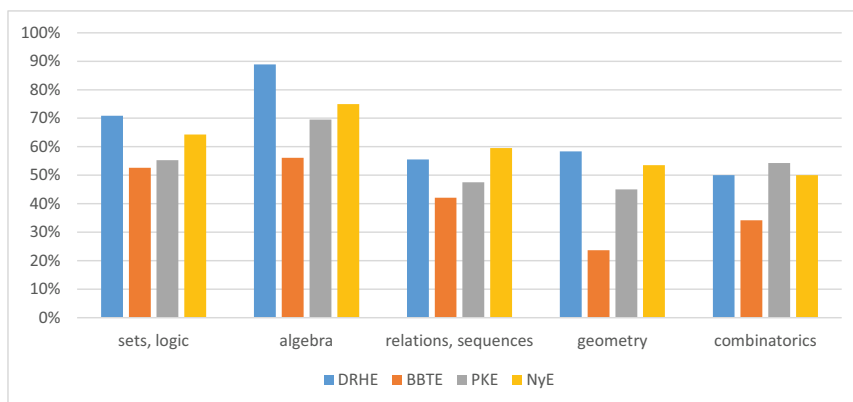

Source: own editing

Diagram 1. Performance of students by content areas.

Students achieved the best results in arithmetic, algebra. They were most successful with these types of problems. The second outstanding area was that of sets, logic. The percentages reveal that the majority of students hardly ever or never encounter competition problems throughout their studies. Consequently, it is an important task of teacher training to prepare teacher candidates for dealing with outstanding pupils.

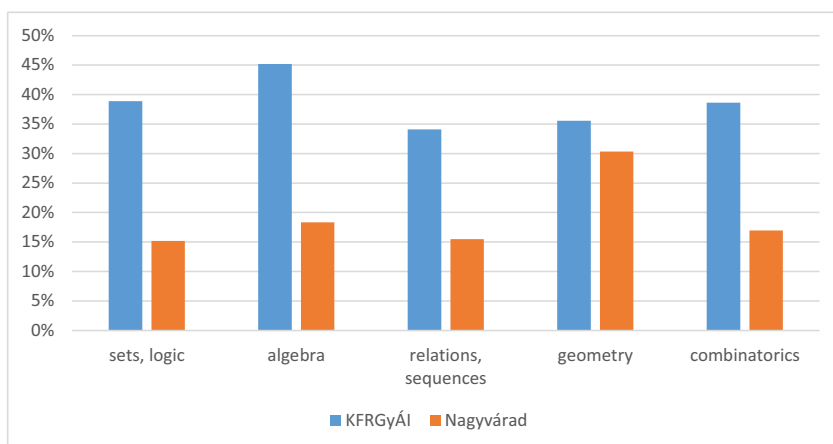

Source: own editing

Diagram 2. Performance of pupils by content areas.

Pupils from Debrecen had mostly consistent results in all areas. Pupils from Oradea achieved better results in the geometry and algebra. More than half of the pupils did not know how to begin solving the problems. They couldn't even reach the 1. step of the model proposed by Pólya. They had difficulty understanding the problem. There were several test papers in which many problems were not even attempted. There were pupils who did not even try to solve the problems.

Diagram 3 shows that in 3 problem-solving strategies students at Debrecen Reformed Theological University achieved better results than students at the other two institutions. Students at Partium Christian University managed to give

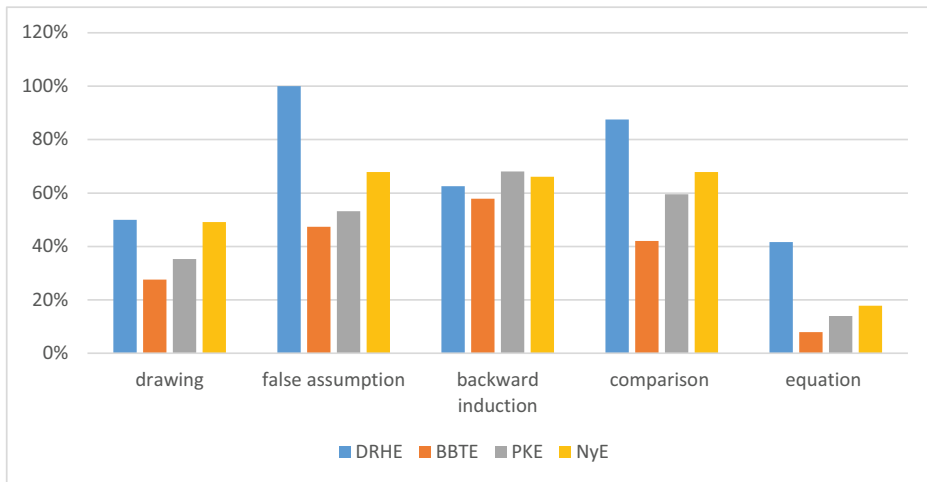

Source: own editing

Diagram 3. Performance of students by problem-solving strategies.

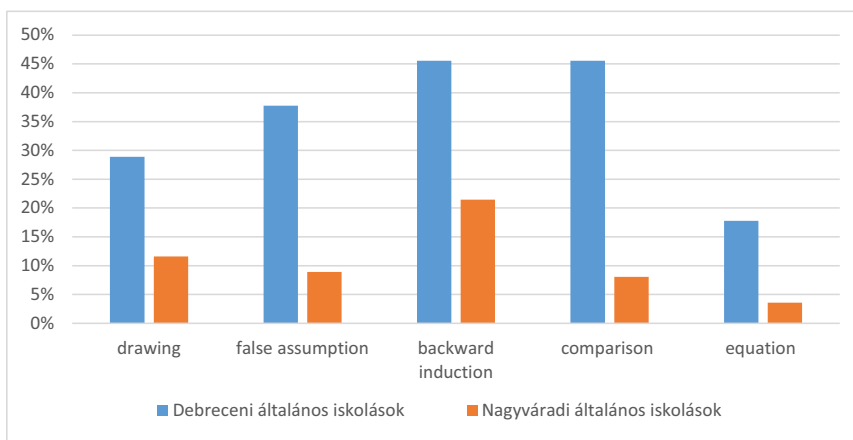

Source: own editing

Diagram 4. Performance of pupils by problem-solving strategies.

more correct solutions when using the backward induction method. Using algebra proved to be the most problematic area for students. We assume that writing the equation is the most difficult step. Students who managed to write the correct equation had no trouble solving the problem.

Diagram 4 shows that pupils at the Reformed Practice Primary School “Ferenc Kölcsey” in Debrecen achieved better results in terms of strategies. However, the diagram also reveals that more than half of the pupils did not use appropriate methods; they could not solve the problems. Average-ability pupils had difficulty solving the problems. This might also be due to the fact that during lessons there is little time for children to familiarize themselves with different methods and their use.

4. Research results

In our research we wanted to find out whether pupils from Debrecen and Oradea achieve different results in the overall test, and if this is the case what is the extent of the differences. As a first step we carried out an F -test of equality of variances.

Table 1. F -test for variances.

	Debrecen	Oradea
Mean	5.3125	2.871428571
Variance	12.19222384	5.648987013
Observations	44	56
df	43	55
F	2.158302685	
$P(F \leq f)$ one-tail	0.003683501	
F critical one-tail	1.60027842	

Source: own editing

The F Statistics is 2.15 with the critical value 1.6. Thus, there is a significant difference between the two variances. The t statistics is 3.97 with the critical value 1.99. From this we can conclude that there is significant difference between the achievements of the two elementary school groups. Pupils at the Reformed Practice Primary School “Ferenc Kölcsey” achieved better results.

Next we investigated the achievements of the students at the four institutions of higher education in the overall test.

Table 2. Analysis of variance.

SUMMARY

Groups	Pieces	Total	Mean	Variance
PCU	47	346.3	7.368085	8.339611
DRTU	13	105	8.75	6.75
BBU	19	101	5.315789	12.78363
UNY	27	225	8.035714	7.665344

Source: own editing

Since the calculated value (F) is higher than the critical value, the achievement cannot be considered similar (Table 3.) There is a significant difference between achievements with a 95% assurance level. Students at DRTU achieved the best results.

Table 3. Summary table.

ANALYSIS OF VARIANCE						
Factors	<i>SS</i>	<i>df</i>	<i>MS</i>	<i>F</i>	<i>P</i> -value	<i>F</i> crit.
Between groups	115.2927574	3	38.43092	4.380122	0.006075	2.693721
Within groups	894.9416765	102	8.773938			
Total	1010.234434	105				

Source: own editing

We have also investigated which problem solving methods were used more frequently by 4th graders. The results are shown in Table 4. We noticed that pupils from Debrecen, who had achieved better results in the test, had used the trial and error method three times more often than pupils from Oradea. The former made an average of 2.45 representations during the problem solving process, while the same value was 1.16 in the group from Oradea.

Table 4. Problem solving strategies used in the test, pupils sample (average/pupil).

	Trial	Representation
Pupils from Oradea	0.23	1.16
RPPSFK	0.73	2.45

Source: own editing

Table 5. shows that students preferred trial, representation and equation as problem solving strategies. The trial method was most often used by students at PCU (on average 1.7 trials per student), representation was most often used by students from Debrecen (on average 4.58 representations per student), and the same group also preferred using equations (on average 3.27 equations per student).

Table 5. Problem solving strategies used in the test, students sample (average/student).

	Trial	Representation	Equation
PCU	1.70	3.06	0.29
DRTU	0.25	4.58	3.27
BBU	0.74	1.89	0.31
UNY	0.03	3.18	1.55

Source: own editing

5. Summary

In this research we hypothesized that pupils use trial and error as a problem solving strategy more often. This is due to the fact that at that particular age writing open sentences (equations) is replaced by this method. In the test more than half of the pupils at the Reformed Practice Primary School "Ferenc Kölcsey" used this method. We found it interesting that pupils from Oradea used the trial method significantly less often. However, the method of representation was used considerably.

In the case of university students we hypothesized that they prefer writing equations and the trial method is less frequently used. This hypothesis was supported by students at Nyíregyháza University and University of Debrecen, however, it was not supported by students at the other two institutions. Taking into consideration that these students are prospective teachers we find it fortunate that representation was used vastly by all groups. This is important because pupils, given their age characteristics, find it easier to understand and acquire problem solving methods with the help of representation.

Investigating the achievements of the four teacher training groups we found that students from Debrecen achieved the best results (63%), followed by students at Nyíregyháza University (57%), students at PCU Oradea came third (53%) followed by students at BBU (38%).

Considering the results their achievement is different since the F-test has shown significant differences in their achievements.

What is the explanation for university students' low success rate in solving 4th grade problems? One of the reasons is lack of knowledge. Students who could not solve the problems seemed to employ limited and erroneous mathematical terms, they did not understand the problem, and could not make a representation or write equations.

It was an overall problem that the steps of making a plan, carrying out the plan and verifying the solution were entirely missing. Students lack knowledge in the theoretical background of problem solving strategies.

As regards the achievement of pupils there is also significant difference in the means. Pupils from Debrecen solved 38% of the test, while pupils from Oradea solved 19% of the test.

The results of our research match the results of previous studies. The curriculum in Romania, does not lay emphasis on using a variety of logical problems and problem solving strategies, consequently, these are rarely present in textbooks or practiced in the classroom. (Lesson observations confirm this fact.) The results of a research show that 80% of elementary school teachers in Romania worry about solving logical and mathematical problems. This fact is surprising since the school curriculum for mathematics does not deal explicitly with this topic. Despite this fact, 70% of teachers find it extremely important to assess complex problem solving skills and 68.5% highly value logical problem solving abilities (Magdaş, Sale 2018).

Our research participants do not use appropriate problem-solving strategies; their strategies are not varied and they are uncertain about them. They often use algorithms they are not familiar with. As regards content areas they had difficulties with algebra and problems requiring representation, even though, these areas are often covered in class.

Non-routine problems provide real-life situations, pose greater challenge and have a positive effect on developing thinking skills, including critical and creative thinking. Consequently, great emphasis should be laid on teaching, practicing and encouraging problem solving heuristics in primary and secondary education, as well as in teaching pedagogy of mathematics.

In teaching mathematics and pedagogy of mathematics further emphasis must be laid on comprehension of mathematical texts and graphical problem solving methods (using segments, figures), as well as developing logical thinking. With the right amount of practice average-ability or weaker pupils can also learn, to a certain extent, the strategies for solving competition problems. This would give them the opportunity to be more successful in problem solving. Consequently, it is of great importance for teacher candidates to be able to solve different problems independently, methodically, and skilfully. This can only be attained if they master different methods, and schemes.

The development process of teacher candidates' problem solving abilities should be observed with the help of a longitudinal study.

Attachment: The mathematics test

- 1) Calculate the result of the following set of operations!

$$21 + 9 \cdot 5 + [476 : 7 - (3 \cdot 7 + 8)] + 0 =$$

- 2) What number divided in half and then divided in half again is equal to a quarter of 1000 divided in half? (2002-county)
- 3) The children have counted the books on the family bookshelf. Anna counted 210, Bea 198, and Cili 215. Mother divulged that one of the children miscounted 12 books, the other 7, and the third 5, but she didn't tell us their names. How many books were there on the bookshelf? (Kenguru 2010)
- 4) In a box there are red, green and blue balls. You have to take out at least 4 balls from the box to have a red ball. You have to take out at least 5 balls from the box to have a green ball. You have to take out at least 6 balls from the box to have a blue ball. How many balls are there in the box? (1998 Zrínyi)

- 5) Using eight identical cubes Pali built the structure below. What does the structure look like from above? (2014-es Kenguru)

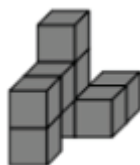

- 6) Children exchanged stamps among themselves. Everybody exchanged one stamp with everybody. How many children exchanged stamps if a total of 6 exchanges have been made? (1999-es Zrínyi)
- 7) If Garfield wakes up hungry one day, the following day he wakes up thirsty, the day after that he wakes up lazy, the third day he wakes up aggressive, the fourth day nice, and the fifth day he wakes up hungry again. How did he wake up on February 25 2018 if on February 1 he woke up hungry? (2000 Zrínyi)
- 8) Two identical birthday cakes are cut into four identical pieces, each. Then each piece is cut into three identical slices. At the end of the party everyone ate one slice of cake, and there were three slices left. How many people were there at the party? (2011 Kenguru)
- 9) You have three number cards. You can form several three-digit numbers with them, for example 989 or 986. How many three-digit numbers can be formed altogether with these number cards?



- 10) The walls of Smurfette's rectangular room are 10 cm and 12 cm long. Smurfette laid down a rectangular carpet on the floor in such a way that the edges of the carpet are parallel with the edges of the room. The carpet covers three quarters of the floor. How many cm is the perimeter of the carpet if the length of two adjacent sides measured in cm is a whole number?
- 11) In a yard there are rabbits and chicken, the total number is 35. The animals have 100 feet altogether. How many rabbits are there in the yard?
- 12) Rabbit stored 40 carrots in two crates, the same amount in each crate. On Monday he ate some carrots from one of the crates, on Tuesday he ate from the other as many carrots as were left in the first crate on Monday. How many carrots are left in the two crates together?
- 13) In a container there is twice as much milk as in another. If we take away 30 litres from the first, 20 litres from the second, in the first container we will have 3 times as much milk as in the second. How many litres of milk were there originally in the container which contained more milk?
- 14) In seven years Dorka will be four times older than her dog, Buksi. Now the sum of their ages is 71. How old is Dorka now?

Test evaluation: each problem is worth **1 point**.

References

- [1] ALTUN, M., ARSLAN, Ç (2006). Problem solving strategies for primary school students. *Uludağ University, Faculty of Education*, 19(1), 1–21.
- [2] AMBRUS, A. (2002). A problémamegoldás tanításának elméleti alapjai. *Új Pedagógiai Szemle*, 52, évf. 10. sz., 157–170.
- [3] AN, SHUHUA, KULM, GERALD, WU, ZHONGHE (2004). The Pedagogical Content Knowledge of Middle School, Mathematics Teachers in China and the U.S. *Journal of Mathematics Teacher Education*, 7, 145–172, retrieved from <https://link.springer.com/journal/10857>.
- [4] APOSTOL, E. M. D. (2017). Problem solving heuristics on non-routine problems of college students. *American Journal of Educational Research*, 5(3), 338–343.
- [5] CRESPO, S. (2003). Learning to pose mathematical problems: exploring changes in preservice teachers's practices. *Educational Studies in Mathematics*, 52, 243–270.
- [6] HENNINGSEN, M. AND STEIN, M.K. (1997). Mathematical tasks and student cognition: Classroom-based factors that support and inhibit high-level mathematical thinking and reasoning. *Journal for Research in Mathematics Education*, 28, 524–549.
- [7] NATIONAL COUNCIL OF TEACHERS OF MATHEMATICS (2000). *Principles and Standards for School Mathematics*. NCTM, Reston, VA.
- [8] NATIONAL COUNCIL OF TEACHERS OF MATHEMATICS (NCTM) (1991). *Professional Standards for Teaching Mathematics*. NCTM, Reston, VA.
- [9] MAGDAŞ, I., SALE, C. A. (2018). Primary school teachers' opinion on mathematical aptitudes of students. *Acta Didactica Napociensia*, 11(2), 11–26.
- [10] OLKUN, S., ŞAHİN, Ö., AKKURT, Z., DIKKARTIN, F. T., GÜLBAĞCI, H. (2009). Problem solving and generalization through modeling: A study on elementary school students. *Education and Science*, 34(151), 65–73.
- [11] PINTÉR, K. (2012). *A matematikai problémamegoldás és problémaalkotás tanítása* (PhD dissertation). Szeged.
- [12] PÓLYA, GY. (2000). *A gondolkodás iskolája*. Budapest: Akkord Kiadó.
- [13] TUZSON, Z. (2003). *Hogyan oldjunk meg aritmetikai feladatokat? Módszertani feladatgyűjtemény*. Kolozsvár: Erdélyi Tankönyvtanács.
- [14] UÑLU, MELIHAN (2018). Examination of mathematics teacher candidates' strategies used in solving non-routine problems. *Acta Didactica Napociensia*, 11(3–4), 97–114.
- [15] YAZGAN, Y., BINTAŞ, J. (2005). Elementary and fifth grade students' ability to use problem solving strategies: A teaching experiment. *Hacettepe Üniversitesi Eğitim Fakültesi Dergisi*, 28, 210–218.
- [16] <http://www.oecd.org/pisa/>

Contact addresses:

Edith Debrenti
Faculty of Economics and Social Sciences,
Partium Christian University
Str. Primariei 36, Oradea, Romania
e-mail: edit.debrenti@gmail.com

Balázs Vértessy
Institute of Mathematics, University of Debrecen
H – 4032 Debrecen, University Square, Hungary
e-mail: vertessy01@gmail.com

Matematikai problémamegoldás a gyakorlatban

Edith Debrenti¹ és Balázs Vértessy²

¹Gazdaság és Társadalomtudományi Kar, Partiumi Keresztény Egyetem, Románia

²Institute of Mathematics, University of Debrecen, Hungary

Kivonat. Az elemi oktatásban, a szöveges feladatok megoldása során többféle módszert használhatunk. Ilyenek az ábrázolás módszere, a hamis feltevés módszere (például az ültetési vagy fejes-lábas feladatok), a fordított út (visszafelé következtetés) módszere, az összehasonlítás módszere, a kiküszöbölés módszere, a behelyettesítés módszere, az egységre való visszavezetés és a mérlegelv módszere.

Problémáról akkor beszélünk, ha van egy cél, egy megoldandó feladat, de nem ismerjük az eléréséhez vezető utat, akadályba ütközünk. Az akadály leküzdésének útja a problémamegoldás folyamata, a megoldás keresését és kidolgozását nevezzük problémamegoldásnak. A problémamegoldó gondolkodást több tényező befolyásolja: előismeret, stratégiák, metakognitív képességek, meggyőződés, beállítódás, de szerepe van az önirányításnak is. Egy probléma megoldása attól függ, hogyan sikerül a meglévő ismereteket, az aktív analízisre való képességet, a gondolkodást, az alkotó hozzáállást mozgósítani. Kutatásunkban 4. osztályos tanulókat, valamint tanítóképzős hallgatókat mértünk fel egy teszt alkalmazásával, melyben különböző módszerrel megoldható feladatokat válogattunk össze. A válaszokban a rugalmas gondolkodást, a megoldási módszerek ismeretét, azok változatosságát, a pontosságot figyeltük és a leggyakrabban előforduló hibákat elemeztük. Feltáró vizsgálatunkat két országban végeztük el: Magyarországon és Romániában.

Kulcsszavak: ismeret, problémamegoldási képességek, érdekes feladatok, felfedezés, stratégiák

Student competence for solving logical tasks

Josipa Jurić¹, Irena Mišurac¹ and Maja Cindrić²

¹Faculty of Philosophy, University of Split, Croatia

²Department of Teacher and Preschool Teacher Education, University of Zadar, Croatia

Abstract. Logical tasks do not require a great knowledge of math, but only require knowledge of basic concepts and logical considerations and conclusions. By inspecting math textbooks for primary and secondary schools we have noticed a considerably small number of them. Even when we did find such a task, it was conceptually or procedurally connected with the contents of the current learning. In order to find out whether the formal mathematical education is preparing students for solving of this kind of problems we have offered them five tasks. Surprisingly, we have discovered relatively small differences in the success of the primary and secondary schools, which indicates that the factual formal education does not contribute to the development of this skill. The analysis of some tasks has shown some surprising results such as, for example, that some of the early primary schools are more successful than older students.

Keywords: problem solving tasks, primary school, secondary school, formal mathematical education, logical conclusion

1. Introduction

The role of mathematics in the contemporary world becomes more and more important regarding its utilization in solving life problems and in logical thinking in general. Nevertheless, students achievements aren't at a satisfactory level especially in situations when they are required to apply mathematical knowledge and skills in realistic problem situations and tasks. This is the best seen in the results of the PISA research, in which Croatia has been participating since 2006, in which Croatian students have been below the average of the OECD countries so far (we haven't got the results from 2018 at this moment, but in the four previous cycles the results have always been below average – from 4.5 % below OECD countries' average in 2009 to 2.9 % below OECD countries' average in 2006 when they achieved the best relative score).

While traditional math lessons have been mostly dealing with the content that students had to learn in a particular cycle of education, contemporary teaching is

turning to the skills and processes that need to be evolved during mathematical education. There is a growing awareness of the importance of applying mathematical concepts and processes in various life circumstances, so the goals of mathematical education are changing towards the development of the overall mathematical literacy of an individual. “PISA defines mathematical literacy as *the ability of formulating, applying, and interpreting maths in different contexts. It helps the individual to recognize the role of mathematics in the world and to make well-founded decisions and judgments that he needs as a constructive, interested and thoughtful citizen.*” [6]. Mathematical literacy of an individual is the main goal of mathematical education.

This wide-set goal requires the development of numerous skills that students need to develop during maths learning at school. The following processes are particularly emphasized (according to NOK, 2010):

1. representation and communication,
2. linkage,
3. logical thinking, argumentation and presumption,
4. problem solving and mathematical modeling,
5. technology appliance.

The development of these skills requires the change of established teaching models that need to be turned from the lecturing and frontal teaching in which the dominant role is the one of a teacher, to students’ independent researching and making presumptions. Particular emphasis is placed on solving problem tasks, since the skill of solving them, especially by applying mathematical models and modeling, can be of a great help to the students in their future life and work.

Problem-based assignment is a task that is usually described in words, and the strategy of solving it is not predetermined. “It includes a variety of life-problem situations that require original and diverse solutions, and various mathematical problems that require students’ anticipation, reflection, conclusion, creativity and autonomy, besides various other problem situations whose solution-seeking strategy is not predetermined. A good problem often has various diverse applicable solutions and it also has many different correct strategies offering its solution, thus stimulating the imagination, motivation and effort of students, strongly stimulating their intellectual activity, and it encourages communication among them giving to the children the opportunity of getting to know the meaning, importance, and benefits of mathematical knowledge. A good problem is not solved by the algorithm, the focus is on the analysis and strategy creation, not on the solving procedure or solution, and it asks for investment of intellectual effort and time, and its successful solution brings students into a state of intellectual excitement and satisfaction” (Mišurac, 2014, 65).

“Problema solving is not a separate theme, but a process that needs to permeate maths learning and provide a context in which concepts and skills will be taught” (NCTM, 2000, 182). Of course, students also develop problem solving skills and problem solving management in various informal problem solving situations (non-formal education). As a rule, people who are more often exposed to problem

solving situations learn more successfully and easily to cope with them. For this reason, it is important to use problem solving assignments in teaching maths in which students have to think logically, connect different mathematical concepts, apply their mathematical knowledge and skills to solve the problem. A special kind of problem solving assignments are logical ones. Logical tasks are those assignments that do not require large mathematical knowledge, but only require basic terms knowledge, logical thinking and inference (Šarić, 1991). Those tasks don't often consist of geometric figures, or numbers, or the stress is not on them, but the logical element prevails. Their advantage to some other mathematical tasks is the one that there is no need for some great mathematical knowledge to solve them, it is sufficient that they require the usage of common sense and logical reasoning, and the texts of those tasks are often formed as small stories that can contribute, apart from development of logical thinking, to the development of students' interest to mathematics (according to Kurnik, 2000). One might say that simpler problem tasks mostly require a sort of conclusion and can be solved by simple calculation or sketching.

By examining maths books for elementary and secondary school we notice that such tasks are rare although they are very suitable for logical thinking and development of interference and creativity.

2. Research methodology

2.1. Subject and purpose of the research

The subject of this research is student's success in solving logical problems. We were interested if the students understand the assignments and do they have appropriate solving strategies and whether they help themselves with the sketches in solving them, and if problem solving skills advance with the progress of the formal mathematical knowledge.

Our aim was to examine students' success in solving logical problems in relation to the level of mathematical education (elementary and secondary school classes).

We have assumed that students with more years of formal mathematics education will be significantly more successful in solving all the offered tasks. We also expected that the strategies used in solving those specific tasks would be more formal and more mature.

2.2. Research sample

The survey was accomplished on 158 elementary school students from grade 2nd to 4th, 345 students from 5th to 8th grade) and 277 secondary school students. The data collecting process was carried out with a survey sheet containing five logical problems selected in a way that could be understood by the pupils of the 2nd grade of elementary school, but that they are also interesting to secondary school students.

The students were divided into three independent groups; elementary school students grades 2nd to 4th, elementary school students grades 5th to 8th and secondary school students. Tasks do not require almost any knowledge or application of more complex mathematical tools, containing natural numbers that students learn at the beginning of schooling and can all be solved by the usage of logical thinking.

We used the arithmetic mean in data processing to show the average result in solving of a task and t-test to determine if the difference between age groups is statistically significant. The following table shows the tasks we used to examine students (Table 1).

Table 1. Questionnaire survey tasks.

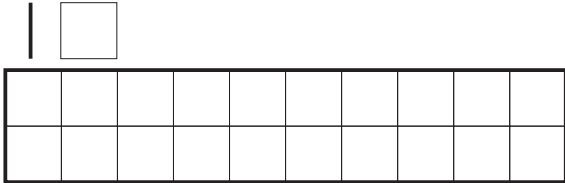
<p>1. A dog chases a rabbit. The moment the dog started doing it, the rabbit was 3 meters ahead. How many leaps the dog has to do to catch up the hare, if the dog makes 3m jumps and the hare 2m jumps?</p> <p>Explanation:</p> <p>Result:</p>
<p>2. Ivo has 24 sticks and 50 tiles as in the picture. He wants to make a rectangle with these sticks and cover it with the tiles, aiming to use as less tiles as possible to fill it. One of his attempts is in the picture. Watch out: He has to spend all 24 sticks. How long the rectangular sides will be if that rectangular needs to contain the least tiles possible?</p>  <p>Explanation:</p> <p>Result:</p>
<p>3. Marco took a bus from Zagreb to Split at 8 a.m.. Ante took a bus ride from Split to Zagreb at 10 a.m. in a similar bus. Their buses met at 12 am at a gas station. Who was closer to Zagreb at that moment?</p> <p>Explanation:</p> <p>Result:</p>
<p>4. Is there more fluid in 1 liter of olive oil or in 1 kilogram of olive oil?</p> <p>Explanation:</p> <p>Result:</p>
<p>5. If 3 eggs in 3 days are hatched by 3 hens, how many eggs are hatched in 6 days by 6 hens?</p> <p>Explanation:</p> <p>Result:</p>

3. Results and interpretation

The following table shows the percentage of solved tasks (Table 2.):

Table 1. Percentage of solved tasks.

	ES(1-4)	ES(5-8)	SS
1st task	26 %	23 %	39 %
2nd task	19 %	12 %	16 %
3rd task	35 %	46 %	64 %
4th task	23 %	20 %	14 %
5th task	24 %	21 %	42 %

It was very surprising to find out that all the tasks in general have a low percentage of solved tasks since we estimated that the tasks could be even presented to elementary school students of lower grades (lower natural numbers, simple formulations, and familiar context). It was noticed in all presented tasks that a large percentage of students did not even try to solve them, and those who solved them just wrote mostly the solution without any note about the procedure or explanation.

We have noticed in the first task that the difference in results between the subgroups of the lower and higher classes of elementary school students was not statistically significant ($p = 0.42$), to be more precise the lower classes elementary school students were somewhat more successful ($AS = 26\%$) than the students in higher ones ($AS = 23\%$). Although this difference hasn't been statistically significant, we find it surprising and indicative, as it demonstrates that the students of both subgroups are on an equal level of skill development in solving this type of problems. The rate of solved tasks in the subgroup made of secondary school students was somewhat higher ($AS = 39\%$), but with such a result we can not be satisfied regarding the extent and level of knowledge that should have been gained so far. Apart the results, we have also studied the modeling method used to solve this problem situation. The character of this problem is such that the right solution could be gained by picture (numerical direction) practically without the application of any formal mathematical strategy. We noticed that 19% students from lower elementary school classes tried to find the solution with a picture, while the percentage of the students from higher elementary school classes was even smaller, only 7%.

The second task is geometric type and requires from the students developed visualization skills, manipulation of geometric objects, and the application of geometric concepts in life context. This task was very poorly solved at all levels ($AS = 15\%$). Additionally, lower classes elementary students ($AS = 19\%$) were better in solving it, even better than secondary school students ($AS = 16\%$). Higher classes elementary school students were the worst in solving this problem ($AS = 12\%$). Although the differences between subgroups have not been statistically significant ($p = 0.36$, $p = 0.19$), we find this result rather bad and surprising as it shows no progress in the application of geometric cognitions in terms of maturity and increased formal mathematical education of students.

Introspecting the strategies in solving this problem we noticed that a large number of students (31 % higher classes of elementary school students and 32 % secondary school students) did not even try to solve the problem. Although we can not conclude consequently that they didn't understand the problem or didn't reflect about it, we think that this percentage is too large considering that tasks include basic geometric concepts.

The third task is a simple and logical life problem that can only be solved by logical thinking and putting it into life context. Although there are some numbers in it, they are not important at all to solve the problem, but only serve to describe the problem situation. Reading and understanding the context or just reading the questions in the task clearly tells us that the participants of the assignment at the time of meeting are equally distant from Zagreb.

Although the percentage of solution in this task is somewhat higher than in the previous one, the results are still extremely poor considering the simplicity and the vitality of the problem. Success in solving this task was 35 % for the students of lower elementary school classes, 46 % for the students of higher elementary school classes and 64 % for secondary school students. The differences are statistically significant what we consider logical and expected.

The fourth task requires students to understand and compare the concepts of fluid volume measurement and the mass. The text and context of the task are understandable and simple, but it is clear that these concepts are only taught in 3rd and 4th grade of elementary school, which somewhat leads to an unequal position of the students. For this reason, their results ($AS = 23\%$) were not considered relevant for the analysis and we did not compare them to other subgroups. We assumed that they speculated the correct result and it turned out that the task was best solved. The subgroups including the students of higher elementary school classes and those students of secondary school have poorly solved this task, the first one 20 %, and the second one 14 %. Among the mentioned groups there are no statistically significant differences in the solvency from which we can conclude that the concepts of fluid mass measurement and volume are not properly accepted in formal education.

The fifth task is a known logical task of a puzzle concept or brain teaser for reflection. Although the task is partly suggested by the numbers appearing in it, it is simple and can be solved by modeling the problem situation. The result of this task was significantly worse for elementary school students (24 % for the students of lower elementary school classes and 21 % for the students of higher elementary school classes) than the secondary school students ($AS = 42\%$). There is no statistically significant difference ($p = 0.48$) between the students of lower and higher elementary school classes, which indicates that formal education does not prepare pupils for solving of this type of a problem. The secondary school students result can't be satisfying because of the nature and simplicity of the task, and we believe that their result reflects with a lack of intrigue and logical thinking.

4. Conclusion

The results of this research lead us to conclusion that our pupils don't have sufficiently developed skills (processes) of modeling and solving problems. Apart from the fact that the percentage of successfully solved tasks is low in all of them, we have noticed that students do not help themselves with modeling or with the utilization of formal mathematical strategies to solve the problems. Formal education doesn't develop this skill, therefore there is no significant progress in the successfulness of different subgroups in solving these tasks. Inclusion of similar tasks in regular mathematical teaching would certainly develop such skills at all levels and it would have to be reflected in better efficacy in problem solving and in greater differences between subgroups according to their mathematical maturity.

We believe that teaching should stimulate more reflexion, self-study and curiosity of students, and the usage of problem tasks to connect mathematics and everyday life and point to its applicability and attractiveness.

Finally we can quote Professor Colin Sparrow (University of Cambridge): "Mathematics is not just a set of skills – it's a way of thinking. It can be found in the heart of understanding science, and rational and logical argumentation.", hence every investment in improvement of the pupils' results is worth an effort and invested endeavour.

References

- [1] BRAŠ ROTH, M., GREGUROVIĆ, M., MARKOČIĆ DEKANIĆ, A., MARKUŠ, M. (2008). *PISA 2006 – prirodoslovne kompetencije za život*. Nacionalni centar za vanjsko vrednovanje obrazovanja – PISA centar, Zagreb.
- [2] KURNIK Z. (2000). Logički zadatci. *Bilten seminara iz matematike za nastavnike-mentore*, 9, HMD, Zagreb, 60–73.
- [3] MIŠURAC, I. (2014). *Suvremeni standardi matematičkih kompetencija u početnoj nastavi matematike*. Jakir, A. (Ed.). Sveučilišni udžbenik, Split, Filozofski fakultet Sveučilišta u Splitu.
- [4] National Council of Teachers of Mathematics (2000). *Principles and standards for school mathematics*. Reston, VA: NCTM.
- [5] ŠARIĆ, M. (1991). *Najljepši logički zadaci – gimnastika uma*.
- [6] Nacionalni centar za vanjsko vrednovanje obrazovanja. Retrieved March 5, 2019 from <https://pisa.ncvvo.hr/sto-pisa-ispituje/matematicka-pismenost/>
- [7] Nacionalni okvirni kurikulum za predškolski odgoj i obrazovanje te opće obavezno i srednjoškolsko obrazovanje, (2010). Retrieved March 10, 2019 from https://www.azoo.hr/images/stories/dokumenti/Nacionalni_okvirni_kurikulum.pdf

Contact addresses:

Josipa Jurić
Faculty of Philosophy, University of Split
Poljička cesta 35, 21000 Split, Hrvatska
E-mail: jjuric@ffst.hr

Irena Mišurac
Faculty of Philosophy, University of Split
Poljička cesta 35, 21000 Split, Hrvatska
E-mail: irenavz@ffst.hr

Maja Cindrić
Department of Teacher and Preschool Teacher Education
University of Zadar
Franje Tuđmana 24i, 23000 Zadar, Hrvatska
e-mail: mcindric@unizd.hr

Pripremljenost učenika za rješavanje logičkih zadataka

Josipa Jurić¹, Irena Mišurac¹ i Maja Cindrić²

¹Filozofski fakultet u Splitu, Sveučilište u Splitu, Hrvatska

²Odjel za izobrazbu učitelja i odgojitelja Sveučilišta u Zadru, Hrvatska

Sažetak. Logičkim zadacima zovemo zadatke za čije rješavanje nisu potrebna velika matematička znanja već traže samo poznavanje osnovnih pojmova i logičkog promišljanja i zaključivanja. Uvidom u udžbenike matematike za osnovne i srednje škole uočili smo zanimljivo mali broj takvih zadataka. Āak i kad se pronađe neki logički zadatak on je konceptualno ili proceduralno vezan uz sadržaj trenutnog učenja. Kako bi zaključili priprema li formalno matematičko obrazovanje učenike za rješavanje ove vrste zadataka odabrali smo ih pet takvih životnog konteksta koje smo ponudili učenicima od drugog razreda osnovne škole do četvrtog razreda srednje škole. Iznenađile su nas relativno male razlike u uspješnosti rješavanja u dobnim skupinama učenika razredne i predmetne nastave u osnovnoj školi te srednjoškola što ukazuje na činjenicu da formalno obrazovanje nikako ne pridonosi dovoljno razvoju ove vještine. Analiza pojedinih zadataka pokazala je neke iznenađujuće rezultate kao na primjer da je u nekim zadacima razredna nastava uspješnija od učenika zrelije dobi.

Cljučne riječi: logički zadatci, razredna nastava, predmetna nastava, srednja škola, formalno matematičko obrazovanje, logičko zaključivanje

Problems and problem situation at the teaching topic example “Number divisibility and applications”

Sead Rešić¹, Fatih Destović², Alma Šehanović³ and Amila Osmić⁴

¹ Faculty of Science, Department of Mathematics, University of Tuzla, Bosnia and Herzegovina

² Faculty of Pedagogy in Sarajevo, University of Sarajevo, Bosnia and Herzegovina

³ Gymnasium “Meša Selimović”, Tuzla, Bosnia and Herzegovina

⁴ Construction geodesy school, Tuzla, Bosnia and Herzegovina

Abstract. Nowadays one of the most important research direction is exploring of mathematical language knowledge, which presents an ability of the person to understand and recognize the mathematics in everyday life, to create conclusions which are supported by the facts and proofs and to apply mathematics in the way that will respond to a life requests. The generally accepted opinion is that the teaching lesson is not efficient if the students are not working active and by themselves, if they are not solving the problems which request a giving an idea, cleverness and a certain level of creativity. It is confirmed that the use of certain education methods can contribute to the development of students' knowledge. In our country, very few experimental studies are done in the number theory area. Considering the importance of students engagement and the development of students' creative ability, we decided to reconsider educational effects one of the modern educational methods, i.e. problem learning with parallel equal groups in the first grade of general high school and in first grade of the mathematical high school on the topic “Number divisibility and applications”.

Keywords: problem learning, number divisibility, lesson organization, experimental observing teaching effects, research results

1. Introduction

The education system is completely well formed and structured teaching process. Every educational system consists of the set of elements which are well connected to each other and create a functional whole. Education systems are the regulators of the complete educating process. An opinion of a huge number of specialists is

that using suitable educational method can bring an advantage to the development of the students well constructed and practical study. The most recent question is which one of the educational methods and techniques is most successful? For the mathematics lesson, one of the educational methods yielding the best results is a problem-based learning.

The kernel of the problem-based learning lesson consists of a problem situation, searching for an idea for the problem situation and checking the compatibility of the idea. When the teacher is explaining how to solve a problem, first of all, he should attract the students' attention by creating the problem situation. This can be done in the following ways:

- The teacher clearly and precisely formulates the question to the students;
- The teacher creates the situation in which the student must understand and formulate the created problem situation itself;
- The teacher creates the situation with more or less clearly formulated problem; using the analysis he should lead the students to the new problem he has predicted;
- The teacher creates the situation with less or more clear problem, which leads the students to the new, additional problem during the problem analysis which the teacher has not completely predicted.

The first way is the simplest one while in the others there are more unknown situations. We are especially interested in the last way since, in that situation, at least one of the component is unknown to the teacher itself, and the students' work is creative and creates a new approach to the problem.

The problem-based learning includes not only asking an introductory question or creation of problem situation, but also independent creative work of a student in the presented problem situation, deduction of new mathematical truths and description of the students mind assumptions.

Structure of the problem-based learning lesson can be divided into several parts:

1. At the beginning of the lesson, the teacher presents a question with the aim of creating a problem situation.
2. Teacher request that the students expose a new hypothesis related to a search for possible problem solution.
3. Problem is decomposed, separating a global problem to the parts of simpler logic whole.
4. Problem is solved immediately, given hypotheses are checked.
5. Deduction of a general conclusion.
6. At the same lesson or later, in new problem situations, students examine the knowledge adopted and recognize the laws in the new cases. Teacher points out only the most important moments, the reasonable connection between terms, a summary of the terms, and not the details.

Problems and the problematic situations at the example of teaching topic “Number divisibility and applications”

Successfully organized problem solving is unthinkable without a well-created problem situation and without a well-formulated problem. One of the reasons why teachers avoid problem-based teaching lies precisely in difficulty of creating a problem situation, respecting its theoretical attributes.

In our country, there exist only a few experimental studies in number theory. So we decided to observe teaching effects of one the most demanding educational methods; problem-based learning lesson for the topic “Number divisibility and applications”.

For our investigation, we have chosen an experiment with parallel similar groups, first grade of general high school and the mathematical high school. Groups are formed after observing students' first-semester success and using the test which measured previous knowledge of the basic concepts in number divisibility. Since we experimented with the students themselves, experiment control was in our hands.

The experiment was done at the end of the second semester after the students are adapted to the new environment. As the experiment included students from the first grade of high school, at the end of the first half of the year, we had data on their success from mathematics. We have formed two groups, experimental with 29 and control with 28 students. The students came from 5 first-grade classes of a general high school and one class of the mathematical high school. Both groups were heterogeneous. Students from mathematical high school are equally distributed in both groups because they had a better predictor. Initial tests were performed as part of regular teaching, while for the implementation of problem-based teaching and final testing we organized 3 lessons, which are not part of regular teaching. Before we started using problem-based teaching, we tested the students with the initial CDINT / 00 test to see what their prior knowledge of the divisibility of the number was. The initial test contained 10 tasks, each scored 10 points.

TEST CDINT/00

1. Write the elements of the set $A = \{x : x \in N \wedge x \mid 9\}$.
2. Find $[2, 3, 4, 16]$.
3. From the set of numbers $\{32, 56, 43, 156\}$ choose those who are divisible by
 - a) 2,
 - b) 3,
 - c) 4.
4. Find $(48, 320)$.
5. Instead of a mark “*” write the suitable digit, such that $58*$ is divisible by 5.
6. Write out twelve prime numbers.
7. Check if the numbers 98 and 143 are coprime.

8. In the set of natural numbers, write the number 882 as a product of prime factors.
9. Without a calculator, check if the number 14141922 is divisible by 6.
10. If the numbers 351 and 466 are divided by the same number, the remainders are 11 and 6 respectively. Find that number.

At the initial test, the maximal number of points to get was 100. The results of an initial test for the questions and average points are written in the following table.

Table 1. Statistics of an initial test.

Problems	E-group	C-group
1.	71,50	70,25
2.	85,60	70,26
3.	73,27	69,70
4.	47,50	42,32
5.	51,35	45,50
6.	25,00	30,80
7.	27,90	17,20
8.	11,50	12,60
9.	5,25	9,36
10.	5,00	7,20

The experimental group at the initial test made an average of 40,39 points, and the control group 37,52 points. The statistical observation of the initial knowledge test has been done by t-test, the difference of arithmetic means of the independent samples.

The results are shown in the following table.

Table 2. Statistics of initial test.

Statistical measure	E-group	K-group
n	29	28
\bar{x}	40,39	37,52
σ	23,52	20,66
V	58,23	55,06
$\sigma\bar{x}$	4,44	3,98
$d\bar{x}$	2,87	
$\sigma d\bar{x}$	5,96	
t	0,48	
Importance level on 0,05	2,01	
Importance level 0,01	2,67	

The table shows that $t = 0,48$, which is below an importance level 0,01 and 0,05 with tolerance degree of 55. The test results showed that both of the

groups have equal knowledge from the part of elementary number theory related to divisibility.

After testing students' pre-knowledge for the part of divisibility, at the control group lesson is conducted at the usual way with the following parts: introduction, putting accent on the aim of the lesson, observing new teaching material, using the monologue method and applying the frontal form of work, homework. For the work in the experimental group, a specially made model was prepared for problem-based teaching. The following is an illustration of the model that we have implemented in the experimental group. The teaching model is executed in three lessons and was divided into the following parts:

1. Creating the problem situation and problem formulation;
2. Hypothesis forming;
3. Problem decomposition;
4. Solving the problem;
5. The result analysis, making conclusions;
6. Practical application of new knowledge by solving specially chosen problems.

The teacher was the one who always helped the students with his advice, directed students' attention on important facts, warned of proper interpretation, until the final dialogue and the solution to the problem.

Creating a problem situation and problem formulation

The lesson started with the problem:

The seller was asked how many apples are in the box. He answered: "If they are counted by two, three, four or six there is always one reminded, if they are counted by seven none of them is left". Find the smallest possible number of apples which satisfies given conditions.

The students are given a bit of time to think about the problem. Some of them tried to guess the result but without the success.

Hypothesis forming

The teacher, through an adequate conversation, mentions the students in forming the following hypotheses:

- Requested number n divided by 2, 3, 4, 5 and 6 certainly gives remainder 1;
- Number n is divisible by 7.

Then, the teacher gives an explanation to students, decomposing the problem, i.e. solving several subproblems to reach the desired solution of the task.

Problem decomposition

The given problem we divided into subproblems.

- Subproblem 1. What does it mean that the number divided by 2, 3, 4, 5 and 6 gives as remainder number 1? What is the form the number can be written?
- Subproblem 2. Evaluate $[2, 3, 4, 5, 6]$?
- Subproblem 3. How can we write down the number if it's known that it is divisible by 7?
- Subproblem 4. What is the rule of divisibility by 47?

Solving the problem

Together with the students, we reconsidered basic concepts about the divisibility at the \mathbb{Z} set, the property of the relation "to be divisible by", showing number in the form $a = bq + r$, well-known divisibility rules, COMMON GREATEST DIVISOR (gcd), and COMMON LEAST MULTIPLE [lcm].

Then we returned to the first hypothesis. Without much trouble students concluded the number n could be written in the form

$$\begin{aligned}n &= 2a + 1, \\n &= 3b + 1, \\n &= 4c + 1, \\n &= 5d + 1, \\n &= 6e + 1,\end{aligned}$$

or equivalently

$$\begin{aligned}n - 1 &= 2a, \\n - 1 &= 3b, \\n - 1 &= 4c, \\n - 1 &= 5d, \\n - 1 &= 6e.\end{aligned}$$

So we concluded the number $n - 1$ is divisible by 2, 3, 4, 5 and 6.

Directing the student to the fact that this conclusion implies $(2, 3, 4, 5, 6) \mid n$, we came to the conclusion that the number $n - 1$ is divisible by $(2, 3, 4, 5, 6) = 60$ so $60 \mid (n - 1)$, hence we get the result that the number $n - 1$ has a form

$$\begin{aligned}n - 1 &= 60k \\n &= 60k + 1, \quad k \in \mathbf{N}.\end{aligned}$$

As the last problem, among all natural numbers of the form $n = 60k + 1$, we should find the least one which is divisible by 7. Students reached the correct result without much trouble.

In the next lesson, we asked the question.

At the table are the books to be packed. If we pack them in the packages containing two books, one book remains on the table. If we pack them in the packages

containing three books, two books have remained on the table. If we pack them in the packages containing four books, three books have remained on the table. If we pack them in the packages containing five books, four books have remained on the table. Find the smallest number of books on the table satisfying the condition.

Considering that the asked question was similar to the previous one, most students succeeded to form the first condition. Which means the number n has a form:

$$n = 2a + 1,$$

$$n = 3b + 2,$$

$$n = 4c + 3,$$

$$n = 5d + 4.$$

Similarly, as in the previous problem, some students subtracted left and right side with suitable numbers, but then a new problem situation came up. On the question “what is the problem”, all of them answered the same: “the remainder is not the same”. Then we started with solving the new problem situation. Students were advised that $a, b, c,$ and d are arbitrary integer numbers so instead of them, we can consider the numbers $a - 1, b - 1, c - 1,$ and $d - 1,$ which are also integer numbers. We have arrived at the conclusion that the number n also has a form

$$n = 2(a - 1) + 1 = 2a - 1,$$

$$n = 3(b - 1) + 2 = 3b - 1,$$

$$n = 4(c - 1) + 3 = 4c - 1,$$

$$n = 5(d - 1) + 4 = 5d - 1.$$

After that students, came up with the result that n is of the form $n = 60k - 1, k \in \mathbf{N},$ hence the least such number is $n = 59.$

Practical application of new knowledge

When the students arrived to the conclusions using problem-based learning, acquired knowledge was being applied on the well-chosen concrete problems

1. If the numbers 351 and 466 are divided by the same number, the remainders are 11 and 6 respectively. Find the number they are divided by.
2. Find all three-digit natural numbers which divided by 7 give remainder 2, divided by 9 remainder 4, and divided by 12 remainder 7.
3. Find all three-digit natural numbers whose sum of digits equals to 10 and which are divisible by 11.
4. The remainder by dividing some numbers by 66 is 14 and dividing by 77 is 5. Find the remainder when the number n is divided by 20.

Problem-based teaching as a more advanced teaching method is considerably more difficult for students. Students feel its weight compared to the solving problem alone. On the other hand, their involvement, as well as the desire to solve a problem, certainly contributed to the positive social climate in the classroom, and that was felt throughout the experiment.

2. Research results

Upon completion of the topic “Divisibility of numbers and applications”, both groups were tested with the same TEST SSGMS / 03. The test contained 11 tasks that covered the material covered during the experiment. The aim of the test was to see to what extent the experimental factor (problem-based teaching) influenced student success. Teachers constructed the tests, using the literature suitable for the first grade of high school. In some tasks, only the knowledge of elementary divisibility rules was required, and some required deeper analysis.

TEST SSGMS/03

1. From the set of numbers $\{2945, 288, 652, 1104, 513\}$ choose those which are divisible by:
 - a) 2,
 - b) 3,
 - c) 4,
 - d) 5,
 - e) 9.
2. Instead of mark “*” write the suitable digit such that “42*” is divisible by 11.
3. Write the elements of the set $A = \{x : x \in \mathbf{Z} \wedge x \mid 15\}$.
4. Evaluate $(1804, 328)$.
5. The sum of two natural numbers is 288, and their common greatest divisor is 36. Find those numbers?
6. If two integer numbers are divisible by number m , then their sum is divisible by the number m . Prove it.
7. If integer numbers a and b give the same remainder by dividing with an integer number c , then the difference $a - b$ is divisible by number c . Prove it.
8. If the numbers 497 and 691 are divided by the same number, the remainders are 2 and 7 respectively. Find the divisor.
9. Find the least 2 and four-digit number which by dividing by 3, 4, 5, 6 and 7 gives remainder 2.
10. Seller is asked how many books does he have. He answered “If I count them by two, three, four, five or six, there are always three books left”. Find the least number of books satisfying those conditions.
11. In the bag, there are balls that should be taken out. If we take out three every time one ball remains in the bag, if we take out four each time two balls remain in the bag, if we take out five each time, three balls are retained in the bag. If we take out fourteen balls each time the bag would remain empty. Find the least number of the balls in the bag.

The success of solving problems on the test is shown in the table.

Table 3. The success of the students at solving each problem.

Problems	E-group	C-group
1.	92,72	78,93
2.	82,76	83,83
3.	45,98	63,60
4.	74,71	37,93
5.	44,83	24,14
6.	44,06	17,24
7.	37,55	16,86
8.	87,74	77,78
9.	82,38	65,57
10.	64,37	29,12
11.	42,07	20,00

From the presented results, we see that starting with problem 11, the experimental group students show better results at nine problems. Three poor solved problems are 6, 7 and 11. Around 20 students in the control group did not even try to solve problems 6 and 7. The greatest difference between the experimental and control group are noticeable in the problems 10 and 11 problems. At the last two problems students have been asked to understand previously presented rules and their applications. Besides, students were asked for a deeper way of mathematical thinking and concluding. If we compare the results of the last three problems, we see the huge differences in the control group. That is one of the pointers to the lack of mathematical language knowledge in the manner of a student ability to solve a real problem using mathematics. Problem 9 was presented in a way that is not immediately visible. Its application in real life was solved with 65,57 Statistical observation of the final test was done with t-test difference using arithmetic means of the independent samples.

Table 4. Statistics of the final test.

Statistical measure	E-group	K-group
n	29	28
\bar{x}	63,31	41,5
σ	23,58	29,22
V	37,25	70,41
$\sigma\bar{x}$	4,46	5,62
$d\bar{x}$	21,81	
$\sigma d\bar{x}$	7,17	
t	3,04	
Importance level on 0,05	2,01	
Importance level 0,01	2,67	

Evaluated – value is 3,04 and shows that the difference of arithmetic means between experimental and control groups gives a great advantage to the experimental

group. The appeared difference could be prescribed to the acting experimental factor or an application of constructed models for learning through solving problems.

Learning through applying problem-based teaching is, as a subject of research in psychological and pedagogical science a relatively well-known area, but as a practice in the teaching not so much. Theoretical and empirical knowledge about this area has not yet been widely applied in educational practice. Given the importance of the student's thoughtful engagement and the development of their creative abilities, we think that in the future more attention should be paid to the effects of applying the problem teaching in mathematics teaching.

3. Advantages and disadvantages of problem teaching

The importance of problem-based teaching and learning is huge considering its effects from pedagogic-psychology and didactic-methodical view. Let us write some of its didactic values:

- Increases the efficiency of educational work,
- Ensures the active studying,
- Develops students independence,
- Develops an increasing ability to connect important relations,
- Ensures perseverance, strengthening students' self-confidence, etc.

Modern mathematics education highlights the problem-based learning as the best method in comparison with other teaching methods. Advantage of the problem-based learning is reflected in greater motivation and self-confidence of the students for learning mathematics, cognitive activation, and development of students creativity.

Problem-based learning presents a demanding teaching method. This method requires more time, because of its composed constitution and a complicated way for its application. All educational topics are not suitable for "problematization" (ex. practicing calculation operations etc.), but in that case, some suitable choice of mathematical contents should be created with components of problem-based learning.

References

- [1] BAKOVLJEV, M. (1983). *Suština i pretpostavke misaone aktivizacije učenika u nastavnom i saznajnom procesu*. Prosveta, Beograd.
- [2] ĐORĐEVIĆ, J. (1972). Rješavanje problema kao oblik stvaralačkog rada u nastavi. *Nastava i vaspitanje*, 3, Beograd, 237–256.
- [3] KVAŠČEV, R. (1968). Nastava i učenje u vidu rješavanja problema. *Pedagogija*, 4, Beograd.

Contact addresses:

Sead Rešić
Faculty of Science, Department of Mathematics, University of Tuzla
Univerzitetska 4, 75000 Tuzla, Bosnia and Herzegovina
e-mail: sresic@hotmail.com

Fatih Destović
Faculty of Pedagogy in Sarajevo, University of Sarajevo
Skenderija 72, 71000 Sarajevo, Bosnia and Herzegovina
e-mail: fatih_d@msn.com

Alma Šehanović
Gymnasium "Meša Selimović"
Tihomila Markovića b.b., 75000 Tuzla, Bosnia and Herzegovina
e-mail: alma.sehanovic@gmail.com

Amila Osmić
Construction geodesy school
Bosne Srebrene 55, 75000 Tuzla, Bosnia and Herzegovina
e-mail: amka_o@hotmail.co.uk

Problemsko učenje na primjeru nastavne teme “Djeljivost brojeva i primjene”

Sead Rešić¹, Fatih Destović², Alma Šehanović³ and Amila Osmić⁴

¹ Prirodno-matematički fakultet, Univerzitet u Tuzli, Bosna i Hercegovina

² Pedagoški fakultet, Univerzitet u Sarajevu, Bosna i Hercegovina

³ Gimnazija “Meša Selimović”, Tuzla, Bosna i Hercegovina

⁴ Građevinsko-geodetska škola, Tuzla, Bosna i Hercegovina

Sažetak. Danas je jedan od najvažnijih istraživačkih pravaca istraživanje matematičkog jezičnog znanja, koje predstavlja sposobnost osobe da razumije i prepozna matematiku u svakodnevnom životu, da stvara zaključke koje potkrepljuju činjenice i dokazi te da matematiku primijeni na način na koji će odgovoriti na životne zahtjeve. Opće je prihvaćeno mišljenje da nastava nije učinkovita ako učenici ne rade aktivno i sami, ako ne rješavaju probleme koji zahtijevaju davanje ideje, razmišljanje i određenu razinu kreativnosti. Potvrđeno je da korištenje određenih obrazovnih metoda može doprinijeti razvoju znanja učenika. U našoj zemlji u području teorije brojeva radi se vrlo malo eksperimentalnih studija. S obzirom na važnost angažmana učenika i razvoj kreativnih sposobnosti učenika, odlučili smo preispitati obrazovne učinke jedne od modernih obrazovnih metoda, odnosno problemskog učenja s paralelnim jednakim grupama u prvom razredu opće gimnazije i u prvom razredu matematičke gimnazije na temu “Djeljivost brojeva i primjena”.

Cljučne riječi: problemsko učenje, djeljivost brojeva, organizacija nastave, eksperimentalno promatranje učinka nastave, rezultati istraživanja

5.

The using of ICT in teaching and learning

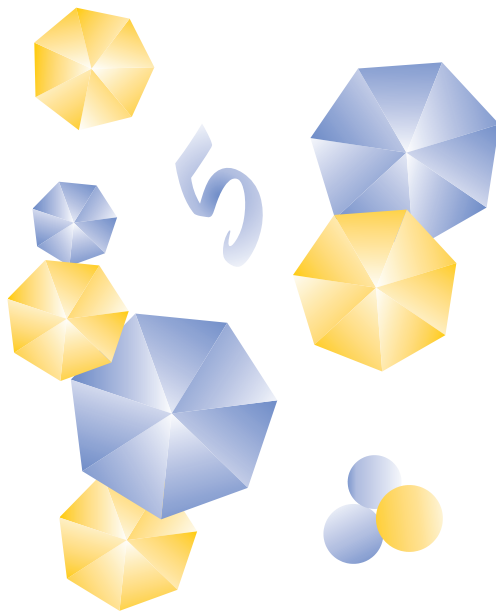

Teaching with the use of ICT – how teachers perceive their own knowledge?

Karolina Dobi Barišić

Faculty of Education, University of Osijek, Osijek, Croatia

Abstract. The traditional educational system, operating on the basis of one-way content transfer, does not enable the acquisition of competences needed in the contemporary society of rapid change and ruthless competition. Digital competence is one of eight core competences highlighted by the Education Council of the European Union and also represent the foundation of Croatian education policy. In Croatia, the importance of new technologies integration into education and research systems is highlighted in the Strategy of Education, Science and Technology, adopted in 2014 (Ministarstvo znanosti, obrazovanja i sporta, 2014).

Theoretical framework *Technological Pedagogical Content Knowledge (TPACK)* describes how teachers understand the interaction between educational technology, pedagogical and content knowledge. This framework represents the mutual influence of the teacher's understanding of educational technology, pedagogical and content knowledge for the purpose of effective application of educational technology in teaching. *Survey of Preservice Teachers' Knowledge of Teaching and Technology (SPTKTT)* represents the self-assessment of knowledge on the application of technology in teaching and was developed on the basis of the TPACK framework.

Two hypotheses are considered in this research: **(H1)** There is a difference in the Croatian teachers' self-perception of knowledge on the use of ICT in teaching in relation to pedagogical and content knowledge, **(H2)** Teachers, who perceive a higher level of technological knowledge, than pedagogical and content knowledge, show greater preparedness for successful integration of technology into education.

Research was conducted in 2015 among Croatian in-service teachers in elementary schools on a sample of $N = 266$ teachers. Both hypotheses were confirmed. According to their self-evaluation, Croatian in-service teachers perceive less knowledge about integration of ICT in teaching in relation to pedagogical and content knowledge. Also, Croatian in-service teachers, that perceive higher level of own technological knowledge, show greater readiness for effective ICT application in teaching.

Keywords: ICT, digital competence, TPACK framework, education, educational technology

1. Introduction

ICT is gaining in importance in modern economies. According to the European Union, a big percentage of current jobs in Europe are in the ICT sector or require ICT, and its importance in the overall European economy has doubled in the last decade. This increasingly technology-rich world has profound implications for education, and ICT may provide significant educational benefits. Given these expected benefits, many countries have undertaken significant investments to enhance the role of ICT in education (OECD, 2010, p. 18). In line with the OECD guidelines, the European Union countries have recognized the importance of investing in ICT for educational purposes (OECD, 2015). For the purpose of achieving technological-related competences for all future participants in the labor market, the integration of ICT in schools has been highlighted (European Commission, 2000).

In 2014 Croatian Parliament adopted Strategy of Education, Science and Technology (Ministarstvo znanosti, obrazovanja i sporta, 2014). Strategy introduces lifelong learning as the principle on which the overall education is based. Closely related to the concept of lifelong learning is the adoption of key competences which, among others, include digital competence, as recommended by the European Parliament and the Council of the European Union. The Strategy predicts measures for the development and dissemination of e-learning, the introduction of expert systems in teaching and other modern teaching and learning methods based on information and communication technology at all levels and in all types of education. Digital sources of knowledge are increasingly available to pupils, students and adults, and the introduction of information and communication technology (ICT), related tools and new digital educational contents also require educators to master them. Also, the ability to introduce such new approaches is important. Accordingly, it is emphasized that open educational contents and tools with free access will be developed and organized, as well as continuous pedagogical, psychological, andragogical and vocational training of teachers.

The advantage of using technology in teaching should be well studied because the pedagogical value of any new approach should be fully established and evaluated before it is applied (Entwistle, 2009, p. 139). The TPACK theoretical framework describes the mutual influence of the teacher's understanding of educational technology and pedagogical content knowledge for the purpose of effective application of educational technology in teaching. In this theoretical framework there are three basic components of the teacher's knowledge: content knowledge (CK), pedagogical knowledge (PC) and technological knowledge (TC). Equally important are their mutual intersections: Pedagogical Content Knowledge (PCK), Technological Content Knowledge (TCK), Technological Pedagogical Knowledge (TPK), Technological Pedagogical Content Knowledge (TPACK) (Figure 1).

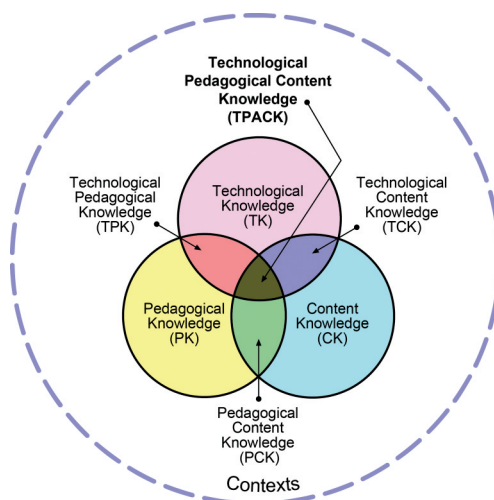

Figure 1. TPACK framework with knowledge components (Reproduced by permission of the publisher, ©2012 by tpack.org).

Overall curricular reform is the first measure with which realization of the Strategy for Education, Science and Technology, adopted by the Croatian Parliament in October 2014, began (Ministarstvo znanosti, obrazovanja i sporta, 2010). It emphasizes the acquisition of knowledge, the development of skills and readiness of children and young people for digital literacy and use of technology. In 2018 started the experimental program “School for Life” which examines the applicability of new curricula, teaching methods and new teaching resources with respect to the following goals: (a) increasing students’ competencies in solving problems and (b) increasing students’ satisfaction with the school and motivating their teachers. Resources for the professional development of teachers for the implementation of the experimental program are planned. Also, the professional training of teachers is being conducted through massive open courses (Eksperimentalni program “Škola za život”).

This article presents self-assessment of in-service teachers’ knowledge of applying technology in teaching before introducing the Complete Curricular Reform and implementation of experimental program “School for Life”. This means that teachers, at the time the research was conducted, did not participate in any education or professional training related to the implementation of the experimental program.

The study explores the following hypotheses:

H1: There is a difference in the Croatian teachers’ self-perception of knowledge on the use of ICT in teaching in relation to pedagogical and content knowledge.

H2: Teachers, who perceive a higher level of technological knowledge, than pedagogical and content knowledge, show greater preparedness for successful integration of technology into education.

2. Literature review

2.1. ICT in education

ICT in teaching encourages critical (Shan Fu, 2013), creative and innovative thinking as well as solving authentic problems (Voogt and Roblin, 2012). In the *Syntesis report on assessment and feedback with technology enhancement* it was emphasized that the use of technology in teaching provides effective teaching methods (Gilbert et al., 2011). In addition, it makes teaching more accessible because it allows 24/7 access (Shan Fu, 2013). The use of ICT in teaching helps in the transformation of the teacher-centered environment into student-centered environment. It helps students to effectively access digital information, supports self-directed learning (Shan Fu, 2013), influences the student's self-confidence and intrinsic motivation (Tseng and Tsai, 2010), enables adapting to the personal learning style, collaborative learning and acquiring teamwork skills (Koehler and Mishra, 2009). Besides that the use of technology in teaching positively affects the students performance (Spieza, 2010; Cheung and Slavin, 2013; Cabras and Tena Horillo, 2016), the investment in ICT and its introduction at all levels of compulsory education is crucial for the development of digital skills (Annals of Public Administration, 2012). ICT enables teachers to create more creative learning environment, improves the quality of learning and teaching and facilitates access to teaching materials. In addition to promoting collaborative learning, it also offers greater opportunities for the development of critical thinking that represent higher order skill (Shan Fu, 2013).

The lack of technological knowledge can pose a problem for successful integration of technology into teaching, both for students and for teachers (Handley et al. 2008). The disadvantages in the context of using technology in teaching are the lack of interaction with students (Hutinski and Aurer, 2009) and the assessment of higher levels of knowledge (Draper, 2009).

Technology can not be a sake of purpose, it is necessary to integrate technology, pedagogical and content knowledge (Romeo et al., 2013; Sweeney and Drummond, 2013; Mouza et al., 2014; Voogt et al., 2014). ICT competence, competence in ICT integration, computer anxiety and pedagogical knowledge influence the teachers' integration of ICT into teaching practices (Aslan and Zhu, 2016). The success of technology integration into teaching process depends, not only on the will of the teachers, but also on the state of the school and its leadership (Dimmock et al. 2013; Thurlings et al. 2014). Integration is faster and more successful if it is the priorities of school leadership and thus perceived as a requirement by teaching staff (Blau and Presser 2013). Teachers need to understand the integration of technology into education as a development of their own knowledge so that the technology's impact on learning and teaching is successful (Wang et al. 2014).

2.2. TPACK framework

Teaching with the help of technology implies three basic components: subject matter, pedagogy and technology, and all their interrelated relationships and impacts, which are integrated into the TPACK theoretical framework (Koehler and Mishra, 2009). The largest application of TPACK theoretical framework is in the area of education and training of teachers. The greatest limitation of the theoretical framework is neutrality in relation to the broader goals of education, e.g. it does not specify which content should be taught nor the way the teacher should taught it (Koehler and al., 2014, p. 109). The integration of ICT in teaching emphasizes the undeniable link between pedagogy and technology (Potkonjak, 2016). Context is an important aspect of educational research as well as the TPACK theoretical framework, but is often omitted in research or its meaning is not clearly stated (Rosenberg and Koehler, 2015). Since it was presented, TPACK framework is widely used. Voogt and associates (2013) have analyzed more than 200 articles in which the TPACK framework was used in two different ways. It was analyzed in relation to technology (Jang, 2010; Krauskopf et al., 2012; Kontkanen et al., 2015) and to contents (Lee, 2008; Grandgenett, 2008; Van Olphen, 2008).

By reviewing literature, there are various ways to measure technological pedagogical content knowledge: self-assessment scale, open questionnaire, performance assessment, interview and observation (Koehler et al., 2012). A measuring instruments have been developed (Valtonen et al., 2015; Koh et al., 2010; Schmidt et al., 2009). One of the most frequently used questionnaires is Survey of Pre-service Teachers' Knowledge of Teaching and Technology (SPTKTT) (Schmidt et al., 2009). As well as any measure of self-assessment, the ability of the SPTKTT instrument to accurately present TPACK domain knowledge is limited to the ability of the respondent to assess his or her own knowledge (Abbitt, 2011).

The results of various researches have shown that the most usually domain of pedagogical knowledge has received the highest scores (Archambault and Crippen, 2009; Chai et al., 2010; Koh et al., 2010; Valtonen et al., 2018), while the domain of Technology Knowledge (Chai et al., 2010) and Technological Content Knowledge has received the lowest scores (Baran et al., 2011; Valtonen et al., 2018).

3. Methodology

3.1. Participants

The sample of respondents in this study is in-service teachers from elementary schools in the Republic of Croatia. The sample was collected from two sources. The first source was the county expert meeting held on April 1, 2015 at the Faculty of Education in Osijek. Out of this first source, 56 respondents were collected. For the second part of the sample, one school from each county was selected, in which questionnaires were sent. Out of this second source, 210 respondents were collected. In total, the sample consisted of 266 respondents. Observed sample

includes teachers who were available for research, meaning that observed sample is not representative sample.

3.2. Instruments

Survey of Preservice Teachers' Knowledge of Teaching and Technology (SPTKTT) (Schmidt et al., 2009) was created for the purpose of examining TPACK development with future teachers. The scale consists of 47 questions with answers that are on the 5-grade semantic ordinal scale on which 1 indicates '*I do not agree at all*' while 5 indicate '*I completely agree*'. Content Knowledge component consists of four subscales: Mathematics, Literacy, Sciences and Social Science. The scale items are distributed to the theoretical framework components in subscales as follows: Technological Knowledge – 7 items, Content Knowledge (Mathematics – 3 items, Literacy – 3 items, Sciences – 3 items and Social Science – 3 items), Pedagogical Knowledge – 7 items, Pedagogical Content Knowledge – 4 items, Technological Content Knowledge – 4 items, Technological Pedagogical Knowledge – 5 items and Technological Pedagogical Content Knowledge – 8 items. Reliability of scale is high, Cronbach $\alpha \geq 0.8$, except for Literacy subscale (Cronbach α (Literacy) = 0.76). Each subscale represents one factor that corresponds to one domain in theoretical framework. Factor structure of the scale is confirmed with factor loadings between 0.59 and 0.92 for all items (Schmidt et al., 2009) indicating that the structure of the scale corresponds to the theoretical framework. The greatest criticism, not the instrument itself, but the validation process conducted by the author of the questionnaire, is that the exploratory factor analysis was made for each of the seven domains separately (Chai et al., 2011).

The SPTKTT questionnaire was translated into Croatian by the double translation method.

3.3. Variables

Variable *Technology* refers to self-assessment of SPTKTT subscales that describe knowledge that involve technology (TK, TCK, TPK, TPACK). Variable *NoTechnology* refers to self-assessment of SPTKTT subscales that describe knowledge that do not involve technology (PK, CK, PCK). The *TPACK* variable represents the teacher's perception of his/her own knowledge on the use of ICT in teaching and is counted as the arithmetic mean of overall SPTKTT survey. *TPACK_{high}* and *TPACK_{low}* represents values of TPACK variable of respondents who perceive a higher level of technological knowledge and respondents who perceive a lower level of technological knowledge, in relation to value of variable *Technology* and *NoTechnology*. If the value of the variable *Technology* is greater than value of variable *NoTechnology* than the value of variable *TPACK* of the observed respondent is one case of the variable *TPACK_{high}*. Otherwise, if the value of the variable *NoTechnology* is greater than value of variable *Technology*, than the value of variable *TPACK* of the observed respondent is one case of the variable *TPACK_{low}* (Table 1).

Table 1. Variables and their definitions.

Variable	Definition
<i>Technology</i>	$(TK+TCK+TPK+TPACK)/4$
<i>NoTechnology</i>	$(PK+CK+PCK)/3$
<i>TPACK</i>	$(TK+PK+CK+TCK+TPK+PCK+TPACK)/7$
<i>TPACK_{High}</i>	TPACK if $Technology > NoTechnology$
<i>TPACK_{Low}</i>	TPACK if $Technology < NoTechnology$

3.4. Data analysis

Before testing the hypotheses, the entered data was verified. Cases in which two or more data were missing were dropped. Cases where missing individual data were left, but missing data were replaced by data calculated based on linear interpolation embedded within the Statistica 13.0 software. For the purpose of testing the normality of distribution statistical and graphical approach was used. Statistical approach includes Kolmogorov-Smirnov and Shapiro-Wilks test, with significance level $\alpha = 0.05$, which verifies the null hypotheses that the variable has a normal distribution in the observed sample. Apart from the above-mentioned tests, a descriptive measure of skewness and kurtosis were used to determine the normal distribution of data, as well as their proportions with corresponding standard errors, which is for a normal distribution between -1.96 and 1.96 (Ghasemi and Zahedias, 2012). Graphical approach encompasses the $q-q$ plot of the observed variable in which the normal distribution is shown as a diagonal line. If the data follows the line, it is assumed that the distribution of the data does not deviate significantly from the normal distribution (Meyers, Gamst and Guarino, 2006, p. 68).

The statistical significance of the difference of the observed variables was checked by the t -test to determine if the means of two sets of data are different from each other. In case of hypotheses H1, t -test for dependent samples was used, considering that two variables are observed for each respondent, *Technology* and *NoTechnology*. In case of hypotheses H2, t -test for independent samples was used, considering that one variable is observed for each respondent (variable *TPACK*) in relation to the mutual relationship of variables *Technology* and *NoTechnology*.

In case that the distribution deviates significantly than normal, non parametric tests were used, Wilcoxon test of paired samples for hypothesis H1 and Mann-Whitney U -test for hypothesis H2.

4. Results

6 cases were dropped out of sample because two or more data were missing. 13 data through 10 items were replaced by data calculated based on linear interpolation.

Descriptive statistics for domains of SPTKTT survey on a sample of $N = 260$ is shown in Table 2.

Table 2. Descriptive statistics for domains of SPTKTT survey on a sample of $N = 260$.

Domain	Valid N	Mean	Minimum	Maximum	Std. Dev.
TK	260	3.667169	1.841615	4.984472	0.678122
CK	260	3.937657	2.583333	5.000000	0.466097
PK	260	4.422127	2.857143	5.000000	0.478723
PCK	260	3.964286	2.000000	5.000000	0.576786
TCK	260	3.842105	2.000000	5.000000	0.633926
TPK	260	4.028947	1.800000	5.000000	0.552139
TPACK	260	3.809925	3.508929	4.093750	0.125740

4.1. Hypothesis H1

Descriptive statistics for variables *Technology* and *NoTechnology* on a sample of $N = 260$ is shown in Table 3.

Tests of normality of distribution has shown that distribution of variable *NoTechnology* does not differ significantly from normal distribution ($K-S$: value = 0.039, $p = 0.2$; $S-W$: value = 0.99, $p = 0.087$), while distribution of variables *Technology* ($K-S$: value = 0.063, $p = 0.014$; $S-W$: value = 0.98, $p = 0.026$) differ from normal distribution. Analysis of skewness, kurtosis and $q-q$ plots has shown that variable *Technology* doesn't differ from normal distribution significantly.

Table 3. Descriptive statistics for variables *Technology*, *NoTechnology*, *TPACK_high*, *TPACK_low*.

Variable $N = 260$	Mean		Skewness			Kurtosis		
	value	stand. error	value	stand. error	value / stand. error	value	stand. error	value / stand. error
<i>Technology</i>	3.87	0.031	0.028	0.151	0.19	-0.190	0.301	-0.63
<i>NoTechnology</i>	4.10	0.026	0.018	0.151	0.17	-0.485	0.301	-0.61
<i>TPACK_high</i>	3.97	0.05	0.15	0.151	0.99	-0.38	0.301	1.26
<i>TPACK_low</i>	3.93	0.03	0.25	0.151	1.66	-0.21	0.301	-0.70

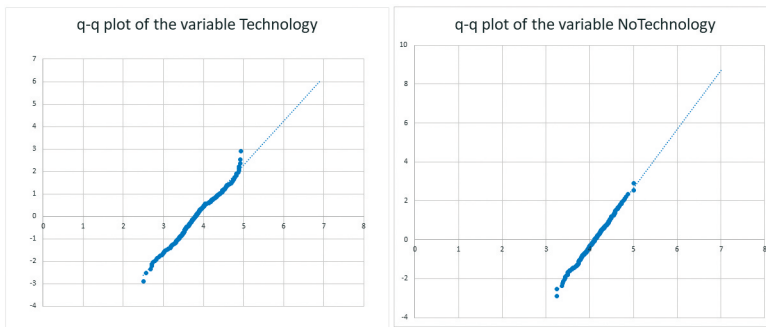

Figure 2. *Q-Q* plots of the variables Technology and NoTechnology on the sample of $N = 260$.

Since, according to Kolmogorov-Smirnov and Shapiro-Wilk tests, the distribution of the *NoTechnology* variable differ from normal distribution, the statistical significance of the difference of the observed variables was verified by the *t*-test for the dependent samples ($t = -9.06$, $p = 0.00$) and further tested by the non-parametric version, Wilcoxon test of paired samples ($z = -8.267$, $p = 0.00$).

The obtained results confirm the hypotheses H1 that teachers in Croatia self-perceive lower knowledge about the use of ICT in teaching in relation to their own pedagogical and content knowledge.

4.2. Hypothesis H2

Descriptive statistics for variables *TPACK_high* and *TPACK_low* is shown in Table 3.

Tests of normality of distribution has shown that distributions of variables *TPACK_high* (*K-S*: value = 0.042, $p = 0.2$; *S-W*: value = 0.79, $p = 0.36$) and *TPACK_low* (*K-S*: value = 0.069, $p = 0.2$; *S-W*: value = 0.83, $p = 0.072$) does not differ significantly from normal distribution.

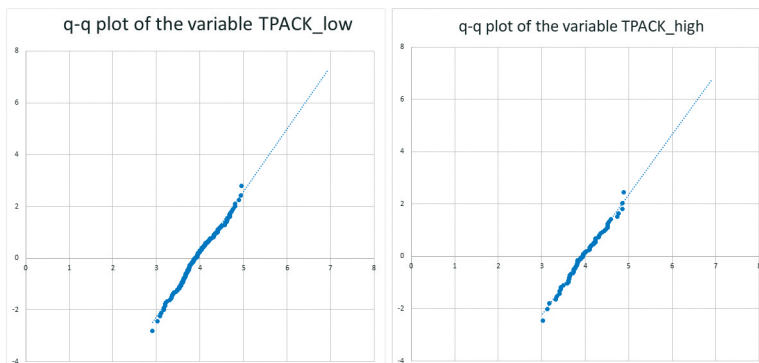

Figure 3. *Q-Q* plots of the variables TPACK_low and TPACK_high.

The statistical significance of the difference of the observed variables was verified by the t -test for the independent samples ($t = -10.025$, $p = 0.00$).

The obtained results confirm the hypotheses H2 that teachers, who perceive a higher level of technological knowledge, than pedagogical and content knowledge, show greater preparedness for successful integration of technology into education.

5. Discussion and conclusion

The sample of respondents who participated in the research is not representative, which means that the conclusions made in this chapter can not be seen as general conclusions but as conclusions derived from this concrete research and for this concrete sample.

Descriptive statistics for domains of the SPTKTT survey showed that teachers in Croatia at the highest level perceive their own pedagogical knowledge ($M = 4.42$), while technological knowledge is experienced at the lowest level ($M = 3.67$). Since the perception of technological pedagogical knowledge is closer to a lower level of technological knowledge than to a higher level of pedagogical knowledge, there is indeed a great need for the development of technological knowledge to make technology integration more successful in teaching. These results coincide with the results of Handley and associates (2008) that the lack of technological knowledge can pose a problem for successful integration of technology into teaching, both for students and for teachers.

The results of the research confirmed the hypotheses H1 that teachers in Croatia perceived lesser own knowledge about the use of ICT in teaching in relation to their own pedagogical and content knowledge. Given that ICT-based teaching appears in all theoretical frameworks about teaching for the 21st century (Voogt and Roblin, 2012), this result challenges the possibility of applying such theoretical frameworks in the Croatian education system. This result is also problematic because *The Strategy of Education, Science and Technology* (Ministarstvo znanosti, obrazovanja i sporta, 2014) highlights the need for introducing modern teaching and learning methods based on information and communication technology at all levels and in all types of education. The lack of technological knowledge can pose a problem for successful integration of technology into teaching, both for students and for teachers (Handley et al. 2008). All this must be taken into account, especially since it is envisaged to have the ability to train teachers, as on technological knowledge as well as the integration of teaching technology through massive open courses (Eksperimentalni program “Škola za život”).

By confirming the H2 hypotheses, we come to the conclusion that teachers with higher technological knowledge are more successful in technology integration in teaching. Teaching with the use of technology results in great benefits for students and the entire education system (Shan Fu, 2013; Tseng and Tsai, 2010; Koehler and Mishra, 2009; Spieza, 2010; Cheung and Slavin, 2013; Cabras and Tena Horillo, 2016). Since teachers need to understand the integration of technology into education as a development of their own knowledge (Wang et al. 2014) it would be

interesting to investigate whether there is any change in technological knowledge and the use of technology in teaching after the introduction of the 'School for Life', which has enabled all teachers to develop their skills, specially in the observed technological context.

Since this research was conducted in 2015, when the 'School for Life' has not been implemented, a similar research would have to be carried out once the 'School for Life' has been successfully implemented in the Croatian education system to examine the extent to which professional teacher training on technological knowledge influences the use of technology in teaching, as well as their desire and willingness to participate in such training.

References

- [1] ABBITT, J. (2011). Measuring Technological Pedagogical Content Knowledge. *Journal of Research on Technology in Education Preservice Teacher Education: A Review of Current Methods and Instruments*, 43(4), 281–300.
- [2] Annals of Public Administration (2012). *Guidelines for the curriculum of pre-primary education and the first cycle of school education*. Special Issue, Milano: Le Monnier.
- [3] ARCHAMBAULT, L. AND CRIPPEN, K. (2009). Examining TPACK among K-12 online distance educators in the United States. *Contemporary Issues in Technology and Teacher Education*, 9(1), 71–88.
- [4] ASLAN, A. AND ZHU, C. (2016). Influencing factors and integration of ICT into teaching practices of pre- service and starting teachers. *International Journal of Research in Education and Science*, 2(2), 359–370.
- [5] BARAN, E., CHUANG, H. H. AND THOMPSON, A. (2011). TPACK: An emerging research and development tool for teacher educators. *TOJET: The Turkish Online Journal of Educational Technology*, 10(4), 370–377.
- [6] BLAU, I. AND PRESSER, O. (2013). e-Leadership of school principals: increasing school effectiveness by a school data management system. *British Journal of Educational Technology*, 44(6), 1000–1011.
- [7] CABRAS, S. AND TENA HORRILLO, J. D. (2016). A Bayesian non-parametric modelling to estimate student response to ICT investment. *Journal of Applied Statistics*, 43(12), 1–16.
- [8] CHAI, C. S., KOH, J. H. L. AND TSAI, C. C. (2010). Facilitating preservice teachers' development of technological, pedagogical, and content knowledge (TPACK). *Educational Technology & Society*, 13(4), 63–73.
- [9] CHAI, C., KOH, J., TSAI, C.-C. I TAN, L. (2011). Modeling primary school pre-service teachers' technological pedagogical content knowledge (TPACK) for meaningful learning with information and knowledge (TPACK) for meaningful learning with information and communication technology (ICT). *Computers & Education*, 57, 1184–1193.
- [10] CHEUNG, A. C. AND SLAVIN, R. E. (2013). The effectiveness of educational technology applications for enhancing mathematics achievement in K-12 classrooms: A meta-analysis. *Educational research review*, 9, 88–113.

- [11] DIMMOCK, C., KWEK, D. AND TOH, Y. (2013). Leadership for 21st century learning in Singapore's highperforming schools. *Educational Research and Innovation: Leadership for 21st Century Learning*, 107–134.
- [12] DRAPER, S. (2009). Catalytic assessment: understanding how MCQs and EVS can foster deep learning. *British Journal of Educational Technology*, 40(2), 285–293.
- [13] *Eksperimentalni program "Škola za život"*, Ministarstvo znanosti i obrazovanja, Retrieved from March 7, 2019
https://mzo.hr/sites/default/files/dokumenti/2018/OBRAZOVANJE/Nacionalni-kurikulumi/Skola-za-zivot/eksperimentalni_program-skola_za_zivot.pdf.
- [14] ENTWISTLE, N. (2009). *Teaching for Understanding at University: Deep Approaches and Distinctive Ways of Thinking*. New York: Palgrave Macmillan.
- [15] European Commission (2000). *Communication from the Commission-e-Learning – Designing tomorrow's education*. COM (2000) 318 final.
- [16] GHASEMI A. AND ZAHEDIAS S. (2012). Normality Tests for Statistical Analysis: A Guide for Non-Statisticians. *International Journal of Endocrinology and Metabolism*, 10(2), 486–489.
- [17] GILBERT, L., WHITELOCK, D. AND GALE, V. (2011). *Synthesis report on assessment and feedback with technology enhancement*. Southampton: UK: Electronics and Computer Science EPrints.
- [18] GRANDGENETT, N. F. (2008). Perhaps a matter of imagination: TPACK in mathematics education. In *Handbook of technological pedagogical content knowledge (TPCK) for educators* (pp. 145–166), New York, NY: Routledge.
- [19] HANDLEY, K., PRICE, M. AND MILLAR, J. (2008). *Engaging students with assessment feedback*. Oxford: Oxford Brooks University.
- [20] HUTINSKI, Ž. AND AURER, B. (2009). Informacijska i komunikacijska tehnologija u obrazovanju: stanje i perspektive. *Informatologija*, 42(4), 265–272.
- [21] JANG, S. J. (2010). Integrating the interactive whiteboard and peer coaching to develop the TPACK of secondary science teachers. *Computers & Education*, 55(4), 1744–1751.
- [22] KOEHLER, M. AND MISHRA, P. (2009). What is technological pedagogical content knowledge? *Contemporary Issues in Technology and Teacher Education*, 9(1), 60–70.
- [23] KOEHLER, M., MISHRA, P., KEREL, K., SHIN, T. AND GRAHAM, C. (2014). The technological pedagogical content knowledge framework. in J. Spector, J. Elen, M. Bishop and M. Merrill, *Handbook of Research on Educational Communications and Technology*, (pp. 101–111), New York: Springer.
- [24] KOEHLER, M., SHIN, T. AND MISHRA, P. (2012). How do we measure tpack? Let me count the ways. in R. Ronau, C. Rakes i M. Niess, *Educational technology, teacher knowledge, and classroom impact: a research handbook on frameworks and approaches*, (pp. 16–31), Harshey: IGI Global.
- [25] KOH, J., CHAI, C. S. AND TSAI, C. C. (2010). Examining the technological pedagogical content knowledge of Singapore preservice teachers with a large-scale survey. *Journal of Computer Assisted Learning*, 26, 563–573.

- [26] KONTKANEN, S., DILLON, P., KÄRKKÄINEN, S., KUKKONEN, J., VALTONEN, T. AND VÄISÄNEN, P. (2015). A Second Life experiment in sex education with pre-service teachers and its contribution to the development of their proto-professional knowledge. *Journal of Educational Enquiry*, 14 (3), 17–36.
- [27] KRAUSKOPF, K., ZAHN, C. AND HESSE, F. W. (2012). Leveraging the affordances of YouTube: The role of pedagogical knowledge and mental models of technology functions for lesson planning with technology. *Computers & Education*, 58 (4), 1194–1206.
- [28] LEE, J. K. (2008). Toward democracy: Social studies and TPCK. in *Handbook of technological pedagogical content knowledge (TPCK) for educators*, (pp. 129–144), New York, NY: Routledge.
- [29] MEYERS, L. S., GAMST, G. AND GUARINO, A. (2006). *Applied multivariate research: Design and interpretation*. Thousand Oaks, CA: Sage Publishers.
- [30] Ministarstvo znanosti, obrazovanja i sporta (2010). *Nacionalni okvirni kurikulum za predškolski odgoj i obrazovanje te opće obvezno i srednjoškolsko obrazovanje*. Retrieved March 9, 2019 from http://www.azoo.hr/images/stories/dokumenti/Nacionalni_okvirni_kurikulum.pdf.
- [31] Ministarstvo znanosti, obrazovanja i sporta (2014). *Strategija obrazovanja, znanosti i tehnologije*. Retrieved March 10, 2019 from http://novebojezanja.hr/UserDocsImages/Dokumenti%20za%20web/Izvj%C5%A1%C4%87e%20o%20provedbi%20SOZT_do%2031.3.2016.pdf
- [32] MOUZA, C., KARCHMER-KLEIN, R., NANDAKUMAR, R., OZDEN, S. Y. AND HU, L. (2014). Investigating the impact of an integrated approach to the development of pre-service teachers' technological pedagogical content knowledge (TPACK). *Computers & Education*, 71, 206–221.
- [33] OECD (2010). *Are new millennium learners making the grade? Technology use and educational performance in PISA*. OECD Publishing, Paris.
- [34] OECD (2015). *Students, computers and learning: Making the connection*. PISA, OECD, Publishing.
- [35] POTKONJAK, V., GARDNER, M., CALLAGHA, V., MATTILA, P., GUETL, C., PETROVIĆ, V. AND JOVANOVIĆ, K. (2016). Virtual laboratories for education in science, technology, and engineering: a review. *Computers & Education*, 95, 309–327.
- [36] ROMEO, J., LLOYD, M., AND DOWNES, T. (2013). Teaching teachers for the future: How, what, why, and what next? *Australian Educational Computing*, 27(3), 3–12.
- [37] ROSENBERG, J. AND KOEHLER, M. (2015). Context and technological pedagogical content knowledge (tpack): a systematic review. *Journal of Research on Technology in Education*, 47(3), 186–210.
- [38] SCHMIDT, D. A., BARAN, E., THOMPSON, A. D., MISHRA, P., KOEHLER, M. J., AND SHIN, T. S. (2009). Technological pedagogical content knowledge (TPACK) the development and validation of an assessment instrument for preservice teachers. *Journal of Research on Technology in Education*, 42(2), 123–149.
- [39] SHAN FU, J. (2013). ICT in education: a critical literature review and its implications. *International Journal of Education and Development using Information and Communication Technology*, 9(1), 112–125.

- [40] SPIEZA, V. (2010). Does computer use increase educational achievements? Student-level evidence from PISA. *OECD Journal: Economic Studies*, 1–22.
- [41] SWEENEY, T. AND DRUMMOND, A. (2013). How Prepared are our Pre-service Teachers to Integrate Technology? A Pilot Study, *Australian Educational Computing*, 27(3), 117–123.
- [42] THURLINGS, M., EVERS, A. T. AND VERMEULEN, M. (2015). Toward a model of explaining teachers' innovative behavior: A literature review. *Review of Educational Research*, 85(3), 430–471.
- [43] TSENG, S.-C. AND TSAI, C.-C. (2010). Taiwan college students' self-efficacy and motivation of learning in online peer assessment environments. *Internet and Higher Education*, 13, 164–169.
- [44] VALTONEN, T., KUKKONEN, J., KONTKANEN, S., MÄKITALO-SIEGL, K. AND SOINTU, E. (2018). Differences in pre-service teachers' knowledge and readiness to use ICT in education. *Journal of Computer Assisted Learning*, 34(2), 174–182.
- [45] VALTONEN, T., SOINTU, E., MÄKITALO-SIEGL, K. AND KUKKONEN, J. (2015). Developing a TPACK measurement instrument for 21st century pre-service teachers. *Seminar Net*, 11(2), 87–100.
- [46] VAN OLPHEN, M. (2008). TPACK: An integrated framework for educating world language teachers. In *Handbook of technological pedagogical content knowledge (TPACK) for educators* (pp. 107–128), New York, NY: Routledge.
- [47] VOOGT, J. AND ROBLIN, N. (2012). A comparative analysis of international frameworks for 21st century competences: Implications for national curriculum policies. *Journal of Curriculum Studies*, 44(3), 299–321.
- [48] VOOGT, J., FISSER, P., ROBLIN, N., TONDEUR, J. AND BRAAKT, J. (2013). Technological pedagogical content knowledge – A review of the literature. *Journal of Computer Assisted Learning*, 29(2), 109–121.
- [49] VOOGT, J., SCHOLS, M., BOTTEMA, J., VAN BERGEN, H., VAN DER STAP, N., TOMSON, A., ET AL. AND THOMPSON, A. (2014). How teacher education institutions cope with challenges of teaching and learning in the digital age. In *Society for Information Technology & Teacher Education International Conference*, 2821–2823.
- [50] WANG, S. K., HSU, H. Y., REEVES, T. C. AND COSTER, D. C. (2014). Professional development to enhance teachers' practices in using information and communication technologies (ICTs) as cognitive tools: lessons learned from a design-based research study. *Computers & Education*, 79, 101–115.

Contact address:

Karolina Dobi Barišić
Faculty of Education
University of Osijek
Cara Hadrijana 10, 31000 Osijek, Croatia
e-mail: kdobi@foozos.hr

Poučavanje uz pomoć IKT-a – kako učitelji doživljavaju vlastito znanje?

Karolina Dobi Barišić

Fakultet za odgojne i obrazovne znanosti, Sveučilište u Osijeku, Osijek, Hrvatska

Sažetak. Tradicionalni obrazovni sustav, koji funkcionira na temelju jednosmjernog prijenosa znanja, ne omogućuje stjecanje kompetencija potrebnih suvremenom društvu brzih promjena i nemilosrdnog natjecanja. Digitalna kompetencija jedna je od osam temeljnih kompetencija istaknuta u obrazovnom vijeću Europske unije te također predstavlja temelj hrvatske obrazovne politike. U Hrvatskoj je važnost integracije novih tehnologija u sustav obrazovanja i istraživanja istaknuta u Strategiji obrazovanja, znanosti i tehnologije, usvojene 2014. godine (Ministarstvo znanosti, obrazovanja i sporta, 2014).

Teorijski okvir Tehnološko pedagoško sadržajna znanja (TPACK) opisuje kako bi nastavnici trebali razumijeti interakciju obrazovne tehnologije, pedagoškog i sadržajnog znanja. Ovaj okvir predstavlja uzajamni utjecaj učiteljevog razumijevanja obrazovne tehnologije, pedagoškog i sadržajnog znanja u svrhu učinkovite primjene obrazovne tehnologije u nastavi. *Survey of Pre-service Teachers' Knowledge of Teaching and Technology (SPTKTT)* predstavlja samoprocjenu vlastitih znanja o primjeni tehnologije u nastavi i razvijen je na temelju TPACK teorijskog okvira.

U ovom istraživanju se razmatraju dvije hipoteze: **(H1)** Postoji razlika u samoprocjeni znanja hrvatskih učitelja o korištenju ICT-a u nastavi u odnosu na pedagoško i sadržajno znanje, **(H2)** Nastavnici, koji posjeduju viši stupanj tehnološkog znanja, od pedagoškog i sadržajnog znanja, pokazuju veću spremnost za uspješnu integraciju tehnologije u obrazovanje.

Istraživanje je provedeno 2015. godine među nastavnicima u osnovnim školama na uzorku od $N = 266$ nastavnika. Obje hipoteze su potvrđene. Samoprocjenom je utvrđeno da hrvatski učitelji posjeduju slabija znanja o integraciji ICT-a u nastavu u odnosu na pedagoška i sadržajna znanja. Također, hrvatski učitelji, koji posjeduju višu razinu vlastitog tehnološkog znanja, pokazuju veću spremnost za učinkovitu primjenu ICT-a u nastavi.

Ključne riječi: IKT, digitalna kompetencija, TPACK teorijski okvir, obrazovanje, obrazovna tehnologija

Mining students' viewpoints about programming in primary education

Ivana Đurđević Babić and Dajana Sabolić

Faculty of Education, University of Osijek, Croatia

Abstract. Nowadays, it is desirable to acquire computer programming competencies and knowledge in different fields of programming. It is well known that someone's viewpoints and attitudes affect their behavior. Therefore, many researchers argue that the teachers' attitudes have an effect on the students' performance and interests (e.g. see Ualesi and Ward, 2018). It could especially influence the teachers' preparedness for lessons (Omolara, and Adebukola, 2015). For that reason, it is important to take into account the opinion of teacher studies students concerning computer programming. This paper tries to make an acceptable classification model for distinguishing students who share the opinion that pupils should be acquainted with basic programming concepts during lower grades of primary education, from those students who do not share this opinion. The students' viewpoints concerning the use of programming in primary education was examined using the k-Nearest Neighbor (kNN) data mining method. It has effectively categorized 77.77% students who support the introduction of basic programming concepts at an early age, and 63.27% of those who do not. This model could be used by students and their educators as a means for improving communication and for encouraging discussions, but it could also be used as an indicator of whether additional student education is needed.

Keywords: kNN, programming, primary school, data mining, students

1. Introduction

In their report, the European Commission (2017) highlighted the necessity of investing in skills which are needed at the labor market, and pointed out Estonia's change of the Aliens Act as an example of how a member of the European union modified its policy to attract ICT workers, major investors and start-up entrepreneurs. It is predicted that there will be as many as 825,000 job vacancies in ICT in Europe by 2020. Even now digital competences, including programming,

are needed in the majority of occupations (European Commission, n. d.). However, programming education in lower grades of primary school is still debated on, with many differences in opinion. Therefore, this research uses the students' viewpoints on programming in primary education as the starting point and uses the k-Nearest Neighbor (kNN) method for distinguishing students with and without a positive attitude towards the idea of introducing programming concepts in lower grades of primary school.

The rest of the paper is organized in the following manner: a short literature review is provided in the next section, followed by the section with the description of used methodology, accompanied by the section where results are provided and explained. After that, the main conclusions and the list of the used literature are provided.

2. Literature review

A great number of researchers looked into the effects which computer programming has on the student's development, confidence and educational performance. Clements and Gullo (1984) focused on the cognitive advantages (cognitive style and development, metacognitive ability, ability to explain direction) in 6-year-old children. They provided evidence that programming can have a positive effect on the cognitive style and metacognitive knowledge, but did not confirm that it influences cognitive development. They also showed that it can improve certain aspects of problem solving. Kalelioğlu and Gülbahar (2014), in their t-test research with 49 5th grade students, did not find any significant improvement in problem solving skills, but did notice a small improvement in their self-confidence about problem-solving skills. They also noticed a more positive attitude towards programming and the students' desire for improving their programming. On the other hand, in their research with 4th and 5th grade primary students, Asad et al. (2016) confirmed that students have a positive attitude towards programming and concluded that programming does increase problem-solving skills. As Kalelioğlu and Gülbahar (2014) clarified, different research designs and contexts could be the reason for varied results. In a systematic overview, Popat and Starkey (2019) analyzed educational outcomes of coding in schools and concluded that other educational outcomes could also be achieved, besides learning how to code (e.g. critical thinking, social skills, self-management, academic and problem-solving skills).

Many researchers directed their research towards the benefits on learning mathematics. For instance, Milner (1973) examined the efficacy of computer programming with the Logo program language on learning the concept of a variable. The results of his research showed that computer programming could serve this purpose. The participants expressed specific problem-solving actions such as planning, debugging or testing hypotheses. Aydin (2005) gave an overview of various uses of computers in mathematics education and the effects of it on the mathematics curriculum. He identified three general types of computer use in this area (computer assisted instructions, programming and educational tools for widespread use) and noted that over time attention shifted from the use of computer assisted instructions to the use of programming. Rich et al. (2014) surveyed 45 people

and interviewed seven programmers in order to detect four effects of programming on mathematics. The participants agreed that programming helped them with the concretization of abstract mathematical concepts, comprehension and use of mathematics, structuring mathematical problems and creating a motivational environment. Messer et al. (2018) examined the impact of programming on the improvement of children's mathematical abilities, spatial awareness and working memory. Furthermore, they compared the efficiency of programming on device with pen and paper programming activities. Compared with other abilities, programming can be useful and programming with and without a device had the same level of achievement. Sáez-López et al. (2019) conducted a research with 93 sixth-grade students where they also explored the impact of visual programming and robotics using mBots on the comprehension of mathematics and science. They incorporated programming and robotics in one mathematics and one science unit and detected a statistical improvement in mathematics, but not in science. Moreover, the participants statistically improved in computer concepts and improved their participation, commitment, motivation and interest. In addition, the authors perceived that their participants had fun while they were mastering subject matter. Misfeldt and Ejsing-Duun (2016), while exploring primary and secondary school curricular activities, organized the relevant significant frameworks and projects into three areas. They observed that students were viewed as producers (e.g. while using the Logo programming language), that programming was used for encouraging abstract thinking (e.g. by employing process oriented programming languages) and that there was an increase in algorithmic thinking which is tied to mathematical thinking.

Maruyama (2018) investigated the parents' concerns about introducing programming in primary education in Japan and revealed that the participants in his research were mainly anxious about the teachers, explaining that the majority of teachers in Japan did not have an education in this field. Moreover, parents were anxious concerning the content that was going to be taught, wondering whether it will differ from school to school and showed concern related with their own knowledge in this area and providing guidance for their children at home. As reported in a research by Maruyama et al. (2017), parents expressed positive attitudes towards programming in primary school, and expressed a high expectation about the children's use of computers, their logical thinking, creativity, problem solving and identifying skills.

Yet, attitudes of teachers and future teachers and a prediction of their attitudes regarding programming in primary school remained somewhat neglected and insufficiently explored. Therefore, this aspect will be examined in this paper.

3. Methodology and results

In the winter semester of the academic year 2018/2019, students from the Faculty of Education in Osijek, class teacher studies (see Figure 1), were asked to participate in this research by completing a questionnaire about their basic views on programming in primary schools.

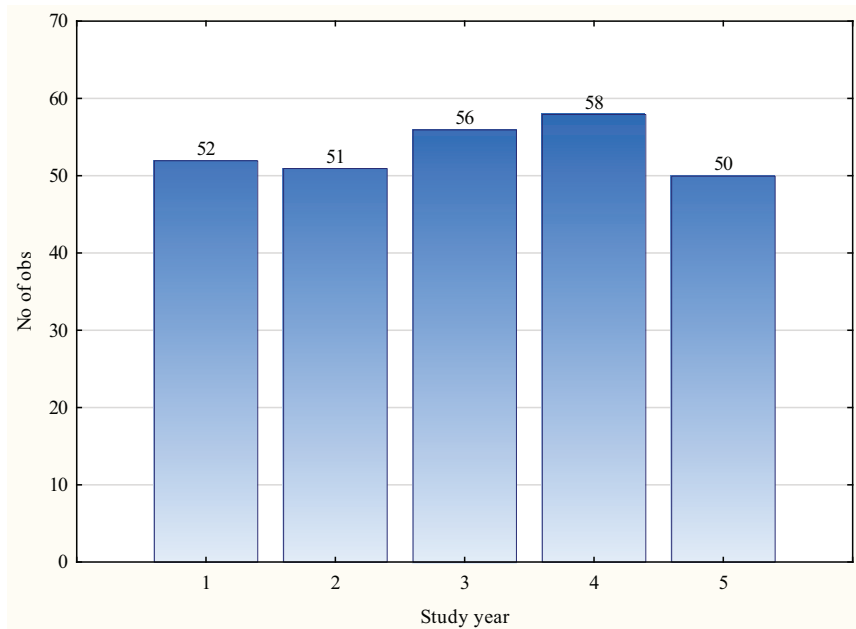

Figure 1. Distribution of participants per study year.

Along with four general demographic questions (gender, study year, age, study module), students were supposed to answer questions or express their agreement with statements which were structured in 5 sections: common statements about programming in primary school (5 statements), benefits of programming in early school years (9 statements), the importance of adopting certain concepts (11 concepts were offered), adequate age to adopt certain terms and suitability of various primary school programming courses (5 programs).

Since k-Nearest Neighbor (kNN) was successfully used as a method in previous research (examples of its use are listed under Shahiri & Husain (2015) and Imandoust & Bolandraftar (2013)) and since it has established advantages such as ease of implementation, great classification accuracy, and not being significantly affected in cases of missing and noisy datasets (as cited in Granda, 2003 according to Golub et al., 1999, Dudoit et al., 2002, Hand et al., 2001, Li et al., 2001), it was used in this research for classification. As described by Phyu (2009), classification of an object in kNN is obtained by the majority of votes of the object neighbors and the object is assigned to the class to which its k-neighbors were classified in a training set. Phyu (2009) noted that the identification of neighbors is performed by presenting an object with position vectors in the feature space and applying a distance measure (the Euclidean distance is frequently used, but other distance measures can be used as well, such as the Manhattan distance). Granda (2003) summarizes this process with a formula:

$$Y = \frac{1}{k} \sum_{x_i \in N_k(x)} y_i \quad (1)$$

where $N_k(x)$ is the neighbor of x with k the closest points when looking at the training sample.

To apply the kNN method in this research, the gathered dataset was randomly sampled and the size of training samples was altered to see how it affects the model's performance. Data that was not assigned to the training sample was used for the test sample. The participants' agreement with the statement *At an early age, students should get familiar with basic programming concepts*, was used as the target variable. The participants' agreements were categorized in two categories: category marked as 0 included all of the participants (160 participants) who did not agree with this statement (in this category, all participant who did fully or partially disagreed with the statement or were neutral were categorized) and category marked as 1 only those participants who agreed (fully or partially) with the statement (107 participants). The feature selection of variables was conducted by excluding variables with strong relationships between them to avoid bias predictions of the model and models' overfitting. The χ^2 test was used for assessing the variables' independence and the value of Cramer's V was used for establishing the strength of the relationship between variables (all variables with Cramer's V higher than 0.3 were eliminated). This led to a decrease in the number of variables, and only 8 variables were used (see Table 1) as independent variables for the kNN model.

Table 1. Variables used as independent variables for model making.

Label	Short description
I1	gender
I2	study year
I3	study module
I4	necessity of using the computer for learning basic programming concepts
I5	can cause vision problems and spinal problems
I6	the essence of adopting the concept of a loop
I7	appropriate primary school grade for understanding the concept of an argument
I8	suitability of the program C++ for learning to program in primary school

For extracting the appropriate model, the training sample was altered (the size ranged from 90 % to 60 %), different distance measures available in Statistica 13 software were applied (Euclidean, Euclidean squared, Cityblock (Manhattan) and Chebychev), the number of nearest neighbors was also changed (it ranged from 1 to 5) and a 10-fold cross-validation was used.

When 60 % of the sample was used for training and the rest for testing, the model was most effective on the test sample. It classified 63.26 % students who did not agree with the statement *At an early age, students should get familiar with basic programming concepts*, and 77.78 % of students who agreed with this statement. These students support the introduction of programming at an early age. This model used the Euclidean distance measure and achieved optimal performance with 4 nearest neighbors. The model's cross-validation accuracy was 60 % (see Figure 2).

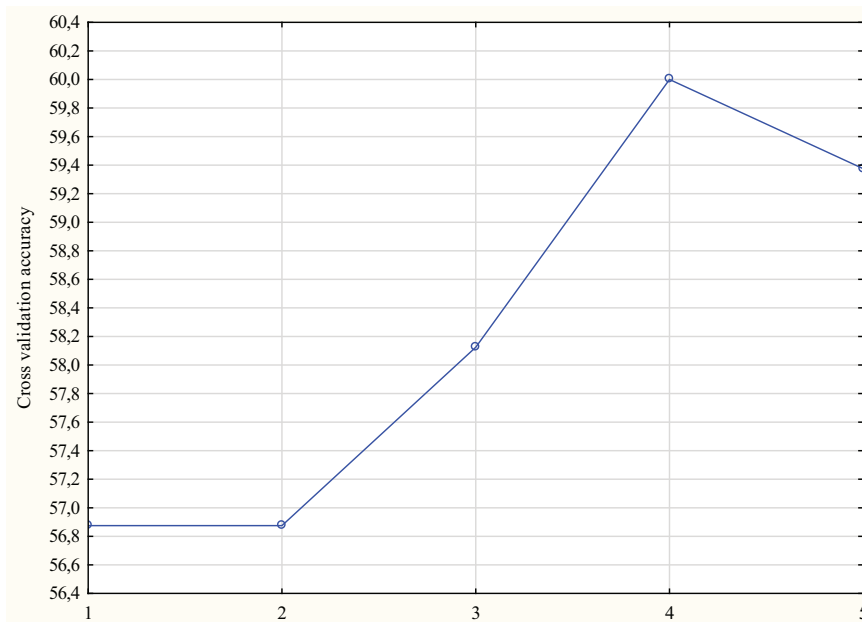

Figure 2. The effect number of nearest neighbors on the models' cross-validation accuracy.

It was noted that changing the distance measure affected the models' performance. When the Chebychev distance measure was applied (see Table 2), the number of optimal nearest neighbors changed to 2.

Table 2. The model's structure and performance when distance measures are changed.

Distance measure	Number of nearest neighbors	Correct classification (%)	
		Class 0	Class 1
Euclidean	4	63.27	77.78
Euclidean squared	4	63.27	77.78
Cityblock (Manhattan)	4	63.27	77.78
Chebychev	2	59.81	0.00

4. Conclusion

A kNN approach for distinguishing students who share the opinion that pupils should be acquainted with basic programming concepts in lower grades of primary education was presented in this paper. With eight variables used as independent variables, the optimal model was obtained when 60.00 % of the sample was used for training. For this sample and variables, the optimal number of nearest neighbors was 4. The model showed a slightly higher accuracy in the classification of students who share the opinion that pupils should be acquainted with basic programming

concepts in lower grades of primary education (77.78 %), from those students who do not share this opinion (63.27 %). Therefore, we can conclude that kNN fulfilled its aim in this research.

The results also showed that this approach could be used for distinguishing and eliminating students' discomfort and bias answers, which can be triggered by asking a direct question. The model successfully distinguished between the students and the results could serve teachers to see if there are diverse opinions concerning programming and whether their students should be further educated in some segment of the topic.

For future research it is recommended to obtain a more diverse sample by including students who study at various faculties and take courses which enable them for teaching programming in primary school. Also, additional factors affecting students' attitudes could be considered and other statistical methods could be employed to explore the associations between them. Besides, the use of other data mining methods for the construction of alternative models could also be beneficial.

References

- [1] ASAD, K., TIBI, M., & RAIYN, J. (2016). Primary School Pupils' Attitudes toward Learning Programming through Visual Interactive Environments. *World journal of education*, 6(5), 20–26.
- [2] AYDIN, E. (2005). The Use of Computers in Mathematics Education: A Paradigm Shift from "Computer Assisted Instruction" towards "Student Programming". *Turkish Online Journal of Educational Technology-TOJET*, 4(2), 27–34.
- [3] CLEMENTS, D. H., & GULLO, D. F. (1984). Effects of computer programming on young children's cognition. *Journal of Educational psychology*, 76(6), 1051.
- [4] European Commission (2017). *Joint Employment Report 2018. As adopted by the EPSCO Council on 15th March 2018*. Retrieved February 18, 2019 from <https://ec.europa.eu/social/BlobServlet?docId=18624&langId=en>
- [5] European Commission (n. d.) *Coding – the 21st century skill. Digital Single Market*. Retrieved February 18, 2019 from <https://ec.europa.eu/digital-single-market/en/coding-21st-century-skill>
- [6] GRANDA, W. V. (2003). Strategies for Clustering, Classifying, Integrating, Standardizing and Visualizing Microarray Gene Expression Data. In E. M. Blalock (ed.), *A Beginner's Guide to Microarrays*, pp. 277–340, Springer, Boston, MA.
- [7] IMANDOUST, S. B., & BOLANDRAFTAR, M. (2013). Application of k-nearest neighbor (knn) approach for predicting economic events: Theoretical background. *International Journal of Engineering Research and Applications*, 3(5), 605–610.
- [8] KALELIOĞLU, F., & GÜLBAHAR, Y. (2014). The Effects of Teaching Programming via Scratch on Problem Solving Skills: A Discussion from Learners' Perspective. *Informatics in Education*, 13(1).
- [9] MARUYAMA, Y. (2018). Investigation into Parents' Concerns about the Introduction of Programming Education into Japanese Primary School. *Procedia Computer Science*, 126, 1037–1045.

- [10] MARUYAMA, Y., KANO, H., & ADACHI, K. (2017). *A Preliminary Investigation into Parents' Concerns about Programming Education in Japanese Primary Schools*. International Association for Development of the Information Society.
- [11] MESSER, D., THOMAS, L., HOLLIMAN, A., & KUCIRKOVA, N. (2018). Evaluating the effectiveness of an educational programming intervention on children's mathematics skills, spatial awareness and working memory. *Education and Information Technologies*, 23(6), 2879–2888.
- [12] MILNER, S. (1973). *The Effects of Computer Programming on Performance in Mathematics*.
- [13] MISFELDT, M., & EJSING-DUUN, S. (2015). Learning mathematics through programming: An instrumental approach to potentials and pitfalls. In K. Krainer & N. Vondrová (Eds.), *Proceedings of the Ninth Congress of the European Society for Research in Mathematics. CERME 9-Ninth Congress of the European Society for Research in Mathematics Education*, Feb 2015, Prague, Czech Republic, pp. 2524–2530.
- [14] OMOLARA, S. R., & ADEBUKOLA, O. R. (2015). Teachers' Attitudes: A Great Influence on Teaching and Learning of Social Studies. *Journal of Law, Policy and Globalization*, 42, 131.
- [15] PHYU, T. N. (2009, March). Survey of classification techniques in data mining. In *Proceedings of the International MultiConference of Engineers and Computer Scientists, I*, pp. 18–20.
- [16] POPAT, S., & STARKEY, L. (2019). Learning to code or coding to learn? A systematic review. *Computers & Education*, 128, 365–376.
- [17] RICH, P. J., BLY, N., & LEATHAM, K. R. (2014). Beyond cognitive increase: Investigating the influence of computer programming on perception and application of mathematical skills. *Journal of Computers in Mathematics and Science Teaching*, 33(1), 103–128.
- [18] SÁEZ-LÓPEZ, J. M., SEVILLANO-GARCÍA, M. L., & VAZQUEZ-CANO, E. (2019). The effect of programming on primary school students' mathematical and scientific understanding: educational use of mBot. *Educational Technology Research and Development*, 1–21.
- [19] SHAHIRI, A. M., & HUSAIN, W. (2015). A review on predicting student's performance using data mining techniques. *Procedia Computer Science*, 72, 414–422.
- [20] UALESI, Y., & WARD, G. (2018). Teachers' Attitudes Toward Teaching Science in a New Zealand Intermediate School. *Australian Journal of Teacher Education*, 43(6), 3.

Contact addresses:

Ivana Đurđević Babić
Faculty of Education
University of Osijek
Cara Hadrijana 10d, 31000 Osijek, Croatia
e-mail: idjurdjevic@foozos.hr

Dajana Sabolić
Faculty of Education
University of Osijek
Cara Hadrijana 10d, 31000 Osijek, Croatia
e-mail: dsabolic@foozos.hr

Rudarenje stavova studenata o programiranju u osnovnom obrazovanju

Ivana Đurđević Babić i Dajana Sabolić

Fakultet za odgojne i obrazovne znanosti, Sveučilište u Osijeku, Osijek, Hrvatska

Sažetak. U današnje vrijeme poželjno je steći kompetencije te znanja iz različitih područja računalnog programiranja. Dobro je poznato da nečija stajališta i stavovi utječu na njihovo ponašanje. Stoga, mnogi istraživači tvrde da stavovi nastavnika utječu na uspješnost učenika i njihov interes (npr. Vidi Ualesi i Ward, 2018.). Posebno, to bi moglo utjecati na pripremljenost nastavnika za nastavu (Omolara i Adebukola, 2015). Iz tog razloga, važno je uzeti u obzir razmišljanja studenata učiteljskog studija o računalnom programiranju. Osvrćući se na stavove studenata o upotrebi programiranja u primarnom obrazovanju, koristeći metodu k-najbližih susjeda (kNN) kao metodu rudarenja podataka, ovaj rad pokušava napraviti prihvatljiv klasifikacijski model za razlikovanje studenata koji dijele mišljenje da bi učenici trebali biti upoznati s osnovnim konceptima programiranja u ranoj dobi primarnog obrazovanja, od onih studenata koji ne dijele to mišljenje. Rezultati su pokazali da je dobiveni kNN model ostvario željeni cilj i učinkovito kategorizirao 77.77% učenika koji podržavaju uvođenje osnovnih koncepata programiranja u ranoj dobi i 63.27% onih koji ne dijele to mišljenje. Ovaj model može poslužiti studentima i njihovim edukatorima kao sredstvo za poboljšanje komunikacije među njima i za poticanje rasprava, ali se može koristiti i kao pokazatelj je li potrebno dodatno obrazovanje studenata.

Ključne riječi: kNN, programiranje, osnovna škola, rudarenje podacima, studenti

The role of online applications as a tool of support in mathematics education

Ana Mirković Moguš

Faculty of Education, University of Osijek, Croatia

Abstract. Mathematics plays an important role in the educational and developmental aspects of each country. Many reports show that students have difficulty learning mathematics. There is some evidence that suggests technology can promote learning mathematics and improve student performance in this area. The aim of this paper is to review the research on the use of online applications for teaching and learning mathematics. Along with investigating the use of applications for mathematics, their influence on students' mathematical learning experience is researched as well. The results of the review implicate a basis for choosing a framework for evaluation and informing teaching decisions about the use of applications to enhance students' conceptual understanding. The framework can be used as a support for teachers' professional development. Results also show that online applications offer benefits in learning and teaching mathematics, but it also seems that a set of technological and pedagogical elements is necessary for the enhancement of mathematics active inclusion, learning and mathematical thinking.

Keywords: technology, support, teacher, mathematics, education

1. Introduction

Using modern technology, including specific tools and applications in education is increasing. A variety of research indicates the importance and possibilities of digital technology for mathematics education. One example is the viewpoint of the *National Council of Teachers of Mathematics* that explains the role of strategic use of technology in the teaching and learning of mathematics. Their position statement states that “Technology is essential in teaching and learning mathematics; it influences the mathematics that is taught and enhances students' learning” (National Council of Teachers of Mathematics, 2015). Also, *Scotland's Curriculum for Excellence* points out that “use of technology in an appropriate and effective way allows for learning experiences that promote enjoyment of mathematics” (Education

Scotland, 2016). However, there are still open questions for teachers, educators and researchers concerning the opportunities of ICT for learning and teaching as well as utilization of these possibilities in mathematics education. Hence the motivation for this paper is to review the research on the use of online applications for teaching and learning mathematics. The reason for reflection on the possibilities of online interactive applications or applets for mathematics education arises along with the growing availability and bandwidth of internet. Another motivating factor why online applications are preferred is the advantage of online content. Online content includes access with no need to install local software and provides availability for users where they can be flexible in using the applications wherever they have internet access and whenever they want to use it. Also, online applications can be used as a support tool to facilitate visualisation of mathematical concepts. Online applications can include different web-based resources like animation using Java applets or interactive tutorials. Along with the review of studies investigating the usage of online applications in mathematics educations, their influence on students' mathematical learning experiences is examined too. Questions which were considered are whether and to what extent mathematics applications available online can help to improve the learning and teaching process of mathematics topics. The research hypothesis is that the online approach grants a better understanding of mathematics.

2. Literature on online applications and mathematics

Different studies investigated the potential of online applications in mathematics educations. For example, Outhwaite et al. (2019) report a study result which indicates the possibility of using the mathematical applications of high quality as a feature of quality math instruction within the established curriculum to raise early math success for all children. Advantages of using web-based resources can help students' to learn mathematics independently. It also enables them to repeat and relearn the material that has been delivered, anywhere and anytime (Kartika, 2018). Furthermore, web resources can ensure that teachers are familiar with other ways of motivating students and raising interest in students (Robová, 2013). Digital learning materials can enhance students' mathematical learning in vocational education, too (Zwart et al., 2017). Another study by Foster et al. (2016) revealed that *Building Blocks* software led to enhanced numeracy achievement in children from low-income backgrounds. This study also implies that adaptive mathematics instruction software programs can be an efficient supplemental method for improving learning difficulties in mathematics for children from ethnic minority and low-income backgrounds. Research of Lin et al. (2016) showed that blended learning pedagogy had a significant positive effect on the student's attitude toward mathematics. Learning supported with online learning management system can help students in learning mathematics adjusted to their own place and time for learning with timely feedback or self-assessment. It also facilitates forum discussion and collaborative learning and thus enhances students and teacher interaction. Using free websites can enable informed teachers many options of motivating and interesting students in mathematics as well as enhancing the clarity of explanation and introducing proactive methods in teaching (Robová, 2013). Applet named *Algebra Arrows* for

creating chains of operations is used for explaining a teaching experiment in school concerning the term of function (Doorman et al., 2012). Their results indicate that the learning process supported with a computer tool helped students to understand better the difficulty of operational and structural component integration of the term of function. It also helped them master it. Bokhove and Drijvers (2012), however, point to effects of digital intervention concerning overcoming algebraic skills. Their results indicate more benefits of using technology in mathematics education for students with weak algebraic expertise. Furthermore, the possibilities for teaching 3D geometry using online applets is examined (Boon, 2009). Frequent obstacle for students concerning their difficulties in making the connection between 3D objects and 2D representations of these objects was a motivating factor for designing a set of educational Java applets to foster spatial abilities in primary and secondary education (Boon, 2009). Another study by Khorasani (2012) showed that students who used the online system for learning mathematic formula obtained more comprehensive knowledge of mathematic formula that refers to the mathematical understanding and application of the mathematical formula. Cheung and Slavin (2013) pointed out that educational technology should be used as a support tool in mathematics and that its effect on learning mathematics is small or neutral. Interactive applications can also be used as a support tool for children with special educational needs and disabilities by increasing their learning standards, yet with limitation for students with severe difficulties (Pitchford et al., 2018).

Positive assessment is also given to an educational technology product named BuzzMath available on a website and as iPad application as a support tool for the practice of middle school mathematics topics. BuzzMath provides a set of math problems in line with the Common Core State Standards (CCSS) which student can access and solve and thus obtain detailed feedback of their achievement. Evaluation results of BuzzMath provided answers to what degree does the use of BuzzMath effects on student learning and engagement as well as on teacher practice (Morisson et al. 2015). Students' and teachers' reactions about BuzzMath were positive and both reflected opinion that the program was effective for enhancing students' learning mathematics (ibid). Specifically, there were 842 students involved in the process of evaluation. Most of the students (89.3 %) stated that the BuzzMath helped them to better understand the material as well as enhanced their presumption of their ability to learn math (81.7 %) (ibid). Students (76.3 %) also agreed that using the BuzzMath helped them to do better on tests and provided them (78.6 %) a personalized way of learning (ibid). Concerning the BuzzMath impact on student engagement, the majority of students (84 %) assesses that the program was attractive and interesting to use as well as the program effected on increasing their (71.8 %) interest in mathematics (ibid). Taking into account the teacher practice, BuzzMath positively supported teachers' plans in realising lesson goal as well as providing them with more free time for individualised instruction with students (Morisson et al., 2015).

While examining the effect of using mobile applications for learning and teaching mathematics, Geogebra and Sketchpad, on the students' achievement Alkhateeb and Al-Duwairi (2019) applied a quasi-experimental study of 105 students. Their results also confirmed that using applications such as Sketchpad and Geogebra contributed to students' better understanding and learning of geometry concepts, even more in the favour of Geogebra application. A group of students who used Sketch-

pad and Geogebra in their learning achieved better results in posttest in contrast to the group where students used traditional methods (ibid). Overall, their study revealed positive effects of using applications such as Geogebra and Sketchpad on the students' achievement (Alkhateeb and Al-Duwairi, 2019). Confirmation of the effectiveness of Geogebra as a support tool in mathematics education as well as for improving student achievement was also shown in a study of Singh (2018).

Another example of using online technology as a support tool is Desmos graphing calculator which was assessed as significant one while implementing the conceptual conflict strategy in teaching of limit (Liang, 2016). This study emphasized Desmos as an additional tool for learning mathematics that cannot replace mathematical logic and reasoning. The traditional way of learning mathematics should still be the first method of choice (ibid). The Desmos graphing calculator was also found beneficial for students in the study of Koştur and Yılmaz (2017). Features that facilitated learning were related to the compensation deficiency of procedural knowledge, enabling possibilities for exploration and supporting students' engagement in learning functions (ibid). Another great resource refers to Corbett Maths websites which many teachers recommend as a support in mathematics education, but there is a lack of student assessment of its benefits. There are many different features gathered from Corbett Maths websites, including the most popular component of the website five a day questions referring to a simple revision format for secondary education. Other websites that provide free and interactive lessons on a variety of mathematic topics include AAA Math, Khan Academy, Coolmath, HippoCampus, Math-Play, IXL and so on. For example, AAA Math contains an extensive set of thousands of interactive arithmetic lessons. Yet, there has been a lack of comprehensive research on students' experience with using these sites.

Positive aspects of using online applications on students' learning experience concerning mathematics have been shown by some studies. For example, Kartika (2018) reports the results of the study that encompass positive feedback on students' satisfaction and learning interest when using a web-based resource. Online learning environment with tutorial clips, online guidance, content structuring and a tool for collaborating helped students improve their achievement in mathematics (Zwart et al., 2017). Specifically, the use of digital learning material has improved math-specific knowledge for students, including numbers and proportions, but not the topic of geometry. The study of Roschelle et al. (2016) found that online mathematics based activities initiated a positive effect on student success at mathematics at the end of the school year. Special benefits were for the students with low prior achievement. Lopes et al. (2015) research results also confirmed that the majority of students (85 %) involved in their study reported that *MatActiva* contribute to their success in mathematics. *MatActiva* was named a project based on the Moodle platform developed to supplement theoretical and practical classes of mathematics. The primary goal of this project was to innovate the teaching and learning process by utilizing technologies as a pedagogical resource as well as to stimulate higher motivation to the students, enhance their learning achievement and enable a set of materials adapted to student needs (Lopes et al., 2015). On the other hand, some research do not confirm the positive effect of technology integration or there are no evidence of its effect on students' learning. For example, within Cyprus Turkish education system the integration of technology in the teaching and learning process

has been prescribed, but there is lack of conducted experimental study that provide evidence in terms of enhancing the learning experience and student success by using technology in Cyprus (Eyyam and Yaratan, 2014).

The results of presented research showed that online mathematics application can be a useful tool to facilitate the process of teaching as well as learning mathematics. Hence, the process of teaching and learning mathematics should include different learning methods by educational means, like the one's online applications offer, that are beneficial in increasing students' motivation and interest in mathematics.

Table 1 provides a summary of the last five-year research on the effectiveness of online applications for mathematics education.

Table 1. Review of research on the effectiveness of online applications in mathematics education.

Author/s	Year	Topic/s	Effect on mathematics learning
Alkhateeb and Al-Duwairi; Singh	2019; 2018	Geogebra, Sketchpad	Positive
Outhwaite et al.	2019	Numbers and proportion, Sorting and matching, Shape and position	Positive
Kartika	2018	Vectors	Positive
Pitchford et al.	2018	Numbers and proportion, Sorting and matching, Shape and position	Positive
Koştur and Yilmaz; Liang	2017; 2016	Desmos	Positive
Zwart et al.	2017	Numbers and proportion	Positive
Zwart et al.	2017	Geometry	Neutral
Roschelle et al.	2016	Mathematics problems with answers and hints	Positive
Lin et al.	2016	Seventh grade mathematics	Positive
Lopes et al.	2015	Algebra, Calculus, Statistic, Financial Mathematics	Positive
Morisson et al.	2015	BuzzMath	Positive
Eyyam and Yaratan	2014	Not specified	No evidence Positive (partly)

3. Discussion

Overall, there are many critical factors for integration of technology in mathematics education. Despite the benefits of using technology in education, just the using of technology is not an implication of providing enough usefulness for learning. Drijvers (2013) singled out key factors in the integration of technology in mathematics which include factors concerning pedagogy, the teacher and the context of education. Robová (2013) also reflects on the teacher's personality and attitudes towards technology as an important factor in assessing the benefits of using technology

in mathematics lessons. Process of effective technology integration encompasses considering not only technology, but also the underlying pedagogy. Hence, considering the review results it seems that existing technological pedagogical content knowledge (TPACK) framework can be applied to inform teachers how technology can best be used for the benefit of students (Picture 1).

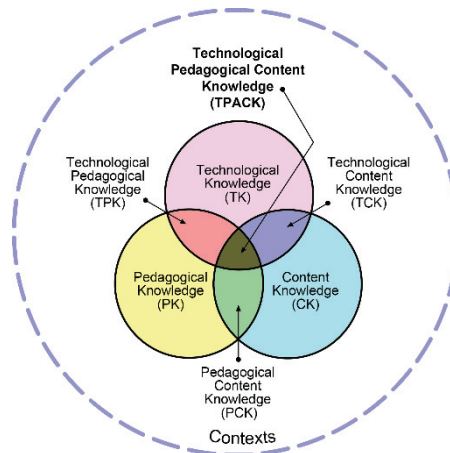

Figure 1. Reproduced by permission of the publisher, © 2012 by tpack.org.

Usefulness of the TPACK framework can be observed in terms of an explanation of the types of knowledge necessary for successful integration of technology in education (Kurt, 2018). Confirmation of relationship between content, pedagogy and new technologies in a dynamic and transaction manner is precondition of every effective use of technology in education (Mishra and Koehler, 2006). In summary, the main benefits of online applications for mathematics can be seen in access and availability of a wide range of teaching materials, enhanced clarity of explanation and visualization, increased motivation of students and student engagement, individual approach to learning, collaborative activities and opportunities to perform self-assessment with prompt feedback. On the other hand, some potential risk of using online applications includes possible problems of the quality of the web content, that is, verification and validation of the online resources that can include mathematical errors on the website, pedagogical deficiencies of teaching materials as well as time demanding for teacher lesson plan organization.

4. Conclusion

Review of research on the use of online applications in mathematics education gave some subtle answers to the questions whether the use of online applications improves student learning, increases students' motivation and satisfaction of learning. Most research reviewed reflected the positive effect of using online applications on mathematics learning in terms of supporting a better and deeper understanding of the topic and providing the practice. Also, the results reflect students' positive attitudes towards using technology in mathematics. However, often the research

sample has been small and with little detail on explanation of factors influencing positive effects but mostly the learners' own perception. In general, the use of most of applications strictly follows a learning and hence a teaching strategy. Technology provides us the ability to expand and enrich mathematics instruction. Overall, educational research concerning the studies on online applications as a tool of support in mathematics help the teacher to understand the phenomena better and indirectly contribute to improving mathematical education. Future research should be more addressed in evaluating the relation of students' experiences of different online mathematics application and their learning outcomes.

References

- [1] ALKHATEEB, M. A., AND AL-DUWAIRI, A. M. (2019). The Effect of Using Mobile Applications (GeoGebra and Sketchpad) on the Students' Achievement. *International Journal of Mathematics Education*, 14(3), 523–533.
- [2] BOKHOVE, C., & DRIJVERS, P. (2012). Effects of a digital intervention on the development of algebraic expertise. *Computers and Education*, 58(1), 197–208.
- [3] BOON, P. (2009). A designer speaks: Designing educational software for 3D geometry. *Educational Designer*, 1(2). Retrieved on January 13, 2019 from <http://www.educationaldesigner.org/ed/volume1/issue2/article7/>
- [4] CHEUNG, A. C., & SLAVIN, R. E. (2013). The effectiveness of educational technology applications for enhancing mathematics achievement in K-12 classrooms: A meta-analysis. *Educational Research Review*, 9, 88–113.
- [5] DOORMAN, M., DRIJVERS, P., GRAVEMEIJER, K., BOON, P., & REED, H. (2012). Tool use and the development of the function concept: from repeated calculations to functional thinking. *International Journal of Science and Mathematics Education*, 10(6), 1243–1267.
- [6] DRIJVERS, P. (2013). Digital technology in mathematics education: why it works (or doesn't). *PNA*, 8(1), 1–20.
- [7] Education Scotland (2016). Curriculum for Excellence: Numeracy and Mathematics Experiences and Outcomes. Retrieved on December 19, 2018 from <https://education.gov.scot/Documents/All-experiencesoutcomes18.pdf>
- [8] EYYAM, R., AND YARATAN, H. S. (2014). Impact of Use of Technology in Mathematics Lessons on Student Achievement and Attitudes. *Journal of Social Behavior and Personality*, 42, 31–42.
- [9] FOSTER, M. E., ANTHONY, J. L., CLEMENTS, D. H., SARAMA, J., & WILLIAMS, J. M. (2016). Improving mathematics learning of kindergarten students through computer-assisted instruction. *Journal for Research in Mathematics Education*, 47, 206–232.
- [10] KARTIKA, H. (2018). Teaching and learning mathematics through web-based resource: an interactive approach. *MaPan: Jurnal Matematika dan Pembelajaran*, 6(1), 1–10.
- [11] KHORASANI, M. K. (2012). An online approach to teaching mathematic formula through introducing web-page links. *Procedia-Social and Behavioral Sciences*, 46, 3546–3550.

- [12] KOŞTUR, M., AND YILMAZ, A. (2017). Technology support for learning exponential and logarithmic functions. *Ihlara Journal of Educational Research*, 2(2), 50–68.
- [13] KURT, S. (2018). Technological Pedagogical Content Knowledge (TPACK) Framework. *Educational Technology*, May 12. Retrieved on January 17, 2019 from <https://educationaltechnology.net/technological-pedagogical-content-knowledge-tpack-framework/>
- [14] LIANG, S. (2016). Teaching the concept of limit by using conceptual conflict strategy and Desmos graphing calculator. *International Journal of Research in Education and Science (IJRES)*, 2(1), 35–48.
- [15] LIN, Y.-W., TSENG, C.-L., CHIANG, P.-J. (2016). The effect of blended learning in mathematics course. *EURASIA Journal of Mathematics Science and Technology Education*, 13(3), 741–770.
- [16] LOPES, A. P., BABO, L., TORRES, C. (2015). The impact of online mathematics education project (MatActiva) on higher education students. *Proceedings of INTED2015 Conference*, 2nd-4th March, Madrid, Spain.
- [17] MISHRA, P., & KOEHLER, M. J. (2006). Technological pedagogical content knowledge: A framework for integrating technology in teachers' knowledge. *Teachers College Record*, 108(6), 1017–1054.
- [18] MORRISON, J. R., ROSS, S. M., LESICZKA, J. K. (2015). *BuzzMath Evaluation Results, Report for iZone*. NYC Department of Education: Results of the BuzzMath Short-Cycle Evaluation.
- [19] OUTHWAITE, L. A., GULLIFORD, A., PITCHFORD, N. J. AND FAULDER, M. (2019). Raising Early Achievement in Math With Interactive Apps: A Randomized Control Trial. *Journal of Educational Psychology*, 111(2), 284–298.
- [20] PITCHFORD, N. J., KAMCHEDZERA, E., HUBBER, P. J., & CHIGEDA, A. L. (2018). Interactive Apps Promote Learning of Mathematics in Children With Special Educational Needs and Disabilities. *Frontiers in Psychology*, 9:262, 1–14.
- [21] ROBOVÁ, J. (2013). The impact of web sites on teaching and learning mathematics. *Procedia-Social and Behavioral Sciences*, 93, 631–635.
- [22] ROSCHELLE, J., FENG, M., MURPHY, R. F., MASON, C. A. (2016). Online mathematics homework increases student achievement. *AERA Open*, 2(4), 1–12.
- [23] SINGH, L. K. (2018). Impact of Using Geogebra Software on Student's achievement in Geometry: A study at Secondary Level. *Asian Resonance*, 7(5), 133–137.
- [24] ZWART, D. P., VAN LUIT, J. E. H., NOROOZI, O., GOEI, S. L. (2017). The effects of digital learning material on students' mathematics learning in vocational education. *Cogent Education*, 4, 1–10.

Contact address:

Ana Mirković Moguš
Faculty of Education, University of Osijek
Cara Hadrijana 10, 31000, Osijek, Croatia
e-mail: amirkovic@foozos.hr

Uloga online aplikacija kao alata podrške u matematičkom obrazovanju

Ana Mirković Moguš

Fakultet za odgojne i obrazovne znanosti, Sveučilište u Osijeku, Osijek, Hrvatska

Sažetak. Matematika ima važnu ulogu u obrazovnim i razvojnim aspektima svake države. Mnogi izvještaji prikazuju da učenici imaju poteškoća u učenju matematike. Postoje neki dokazi koji upućuju na tehnologiju kao pomoć u promicanju učenja matematike i poboljšanju uspješnosti učenika u matematici. Cilj je ovog rada dati pregled istraživanja o korištenju online aplikacija za poučavanje i učenje matematike. Osim toga, ispitan je i utjecaj online aplikacija na iskustvo učenja matematike od strane učenika. Rezultati pregleda daju osnovu za odabir okvira za evaluaciju i informiranje učiteljskih odluka o korištenju aplikacija u svrhu poboljšanja učeničkog konceptualnog razumijevanja. Okvir se može koristiti i kao podrška stručnom razvoju učitelja. Rezultati također upućuju da online aplikacije nude prednosti u učenju i poučavanju matematike, ali je također potreban i skup tehnoloških i pedagoških elemenata nužan za poboljšanje aktivnog uključivanja u matematici, matematičkog učenja i razmišljanja.

Ključne riječi: tehnologija, podrška, učitelj, matematika, obrazovanje

Computer-based assessments in mathematics at the higher education level

Josipa Matotek

Faculty of Civil Engineering and Architecture, University of Osijek, Croatia

Abstract. An important part of teaching and learning process is evaluation of students' knowledge. Often, evaluation of mathematical knowledge at university level is carried out in two phases. The first phase is evaluation of task-solving ability and the second phase is the evaluation of mathematical theoretical knowledge. Due to an increase in the use of Information and Communication Technologies (ICT) in teaching and learning processes, there are more and more examples of computer-based assessments.

The paper presents the author's years of experience in using computer-based assessments since the author has been used them (in second phase of evaluation), in Learning Management System named Moodle since 2011, within the course Mathematics for Engineers 1 of the undergraduate professional study program at the Faculty of Civil Engineering and Architecture, Osijek. The paper points out the differences between paper-and-pencil and computer-based assessments, referring to different approach to creating questions and ways of implementing the exam itself. Additionally, it discusses the results of computer-based exams, and gather students' overall impression of this type of assessment.

Finally, the aim of this paper is to highlight the advantages and disadvantages of using computer-based assessments in mathematics at the higher education level.

Keywords: evaluation of knowledge, mathematics, computer-based assessment, paper and pencil exam, higher education level

1. Introduction and preliminaries

There has been a considerable amount of research studies focused on the assessment of student learning outcomes. Apart from using grades as the basis for assessing learning outcomes, the assessment is used for many other purposes – e.g. for teaching and learning, for self-assessment, etc. Newton distinguishes even 18 uses of educational assessment which includes diagnostic purposes, placement purposes,

system monitoring purposes, etc. But two main ways of assessing student progress are summative and formative assessments (Newton, 2007). Many authors also pointed out the classification of large scale and classroom assessment. The purpose is important since the design of assessment as well as the interpretation of the results should depend on the purpose of the assessment (Suurtamm et al., 2016). However, National Council of Teachers of Mathematics (NCTM) in their Principles and Standards for school mathematics specified that assessment should support the learning of important mathematics and furnish useful information to both teachers and students (Midgett, 2001). Furthermore, every assessment, regardless of its purpose, should not be used just to measure learning, but also to support student learning (Wiliam, 2007).

Assessment design is influenced not only by the purpose, but also by goals. According to Swan and others, alignment between assessment and the curriculum goals is very important (Swan et al., 2012). Suurtamm and others in their book gave an overview of different assessment goals from various perspectives such as determination and evaluation of students' mathematical achievements as well as their experiences gained from assessment opportunities or involvement in their own learning through activities such as self-assessment, etc. (Suurtamm et al., 2016).

A lot of articles have already been written on the assessment and task design and new and innovative methods of teaching and learning (such as computer-based assessment) have been constantly introduced and upgraded. Many various approaches to the assessment design are presented in the ICMI Study 22 Task Design in Mathematics Education (Watson et al., 2015). Swan specified eight principles that tasks should include. Some of them are: „Task should provide opportunities for students to determine what strategy they want to use in order to pursue a solution, task should provide opportunities to demonstrate chains of reasoning and receive credit for such reasoning, even if the final result contains errors...“ (Swan et al., 2012).

Since this article deals with computer-based test, following paragraph points out some research results specifically in regards to computer-based assessment. U.S. Department of Education has conducted a research study about online assessment in mathematics, dealing with following four key issues: measurement, equity, efficiency and operational issues. According to this study, „paper presentation may allow some skills to be assessed that computer delivery does not, and vice versa“. Analyzing assessment results, they concluded that students' performance was better in paper than in computer test version (Sandene et al., 2005). Similar findings occurred in some other studies as well – e.g. study conducted by Backes and others (Backes et al., 2018). Some test results are not significantly different regardless online or paper delivery (Shudong, 2004, Way et al. 2006). Furthermore, results showed that groups categorized by gender, race/ethnicity, parents' education level, school type, etc. generally were not differentially affected by exam delivery mode (Sandene et al., 2005).

Additionally, students have positive attitudes towards computer-based tests, they tend to prefer it to traditional paper-pencil test (Way et al., 2006). This is important because positive attitudes towards test might possibly lead to positive attitudes towards mathematics in general. Matotek showed that there is a statis-

tically significant difference in attitudes towards mathematics regarding students' achievements in mathematics exams (Matotek, 2017.)

2. Methodology-computer-based test

The author of this article teaches *Mathematics for Engineers I* to the first-year students of the undergraduate professional study at the Faculty of Civil Engineering and Architecture, Osijek. The final exams in this part of Europe, including Croatia too, mainly consists of two parts: a written and an oral section. It means, as far as mathematics is concerned, that written exam focuses on solving different types of mathematical tasks whereas oral exam covers definitions, properties, examples with applications, theorems with their proofs etc. However, it is slightly easier for students enrolled in the undergraduate professional study of Civil Engineering since they do not have to know theorems and their proofs.

Since implementing the Bologna process in Croatia, students have had the opportunity to take so called preliminary exams or quizzes (usually two or three of them) during the semester instead of final exams at the end of each semester. Regarding differences between final and preliminary exams, the latter are used only in written form (both, calculations and theory).

However, evaluation of these kinds of exams has been considered rather difficult. Therefore, the need to introduce some changes has appeared justified. Since 2011 the theoretical part of the first (out of three) preliminary exam has been delivered to students via computers, by using computer-based activity called *test* in Learning Management System named Moodle. Another reason for using ICT was to make the test more attractive and interesting to students, and finally last but not least is to “modernize” student assessment methods.

Table 1 shows the number of students who solved computer-based exam from 2011 till 2018 – 340 students in total.

Table 1. The number of students who solved computer-based exam.

Year	2011.	2012.	2013.	2016.	2017.	2018.	Σ
Number of students	51	59	59	58	55	58	340

3. Results and discussion

3.1. Challenges of creating question database

The biggest challenge for a startup was creating almost completely different types of questions in relation to the written questions. However, several important issues had to be considered:

- Students' prior knowledge and skills on using ICT in mathematics was not taken into consideration and it should not be assumed that students can use

mathematical notation on computers, which led to another problem; other types of questions had to be used rather than essay type – e.g. matching pairs, cloze type (embedded answer), multiple choice, short answer, true – false type.

- Exam questions should be adjusted to assessment objectives (e.g. to evaluate students' understanding of certain terms and relating them to previously acquired knowledge instead of evaluation of isolated terms recognition).
- A big question database had to be created (at least three or four times more questions for the computer-based test than for the pencil test).

From academic 2017 / 2018 year, computer-based assessment in the theoretical part of second preliminary exam was also introduced.

A selection of sample test questions is given below. The first two examples were chosen from theoretical part of the first preliminary exam, including the lessons about sets, sets of numbers and vectors in 2-space and 3-space.

Example 1: Which one is the smallest superset of the set of natural numbers? Choose one answer:

- a. **C**
- b. **R**
- c. **Q**
- d. **Z**

Example 1 presents multiple choice question type, but knowing correct answer requires students' knowledge of not only definitions of superset and sets of numbers but also linking these terms.

Example 2: Vectors \vec{a} and \vec{b}_a are mutually collinear. Choose one answer:

- True
- False

Example 2 represents true-false question type. With appropriate negative marking (it is possible to do this with some question types in the Moodle activity *test*), the issue of random guessing can be reduced considerably. However, the author did not use it. Correct answer to this question requires students' understanding of collinear vectors and vector projection and linking knowledge of these two things.

The next two examples were chosen from theoretical part of the computer-based second preliminary exam which includes the lessons about elementary functions, their domains, graphs and different properties. It is easy to check whether students know to draw graphs of elementary function in paper-based exams. But computer-based exam requires a different approach while designing tasks in order to check their ability to connect function equations with corresponding graphs.

Example 3: The graph of the function $y = -(x + 3)^2 - 1$ has the vertex in point with coordinates (,). Determine whether the parabola opens: (from the drop-down menu students choose as in Figure 1) up, down, left, or right.

Pitanje 1
Nije još odgovoreno
Broj bodova od 3,00

Graf funkcije $y = -(x+3)^2 - 1$ ima tjeme u točki (,), a okrenuta je prema .

gore
dole
lijevo
desno

Ponovno započni Pohrani Unesi točne odgovore Predajte i završite Zatvori pregled

Figure 1. Original question from exam about parabola.

Example 3 presents usage of embedded answer (cloze) question type. From the technical aspect, creating of it was a bit complicated. This question is worth three points. For the maximum number of points, students had to know the implication of parabola properties like the shifts of the graph of the function $f(x) = x^2$ and the determination of the vertex from the equation.

In the next example the objective is reverse, the equation should be determined from the given curve.

Example 4: Determine equation from the drawn function graph (see Figure 2).

Pitanje 1
Nije još odgovoreno
Broj bodova od 1,00

Odaberite jednadžbu nacrtane funkcije:

Odaberite jedan odgovor:

$y = e^x - 1$
 $y = \ln(x-2)$
 $y = e^{x-2}$
 $y = \ln x - 2$
 $y = e^x - 2$
 $y = e^{x-1}$

Ponovno započni Pohrani Unesi točne odgovore Predajte i završite Zatvori pregled

Figure 2. Original question from exam about determination of logarithmic equation.

The example 4 shows another useful implementation of multiple-choice question type. In order to solve the task correctly, students must know the properties of

graphs of logarithmic and exponential functions, and consequently conclude which equation is required.

It is interesting to point out that the number of the tasks created is a several times higher than the number of tasks that exam contains. The following example illustrate this: 38 questions were created for the first computer-based test that contains 11 questions and 31 questions for the second computer-based test that contains 10 questions. Obviously, it takes a lot of time to create such a test, but its benefits come to light when it comes to evaluating. With option “make a copy” and with small changes in origin it could be easily generated a new question. Some types of questions can be even automatically generated in Moodle or with some other software application (Sandene et al, 2005).

3.2. Challenges of exam implementation

After creating question database, it should be ensured that all students get all types of questions by creating categories containing similar questions. For example, four tasks about parabola (like example 3) were created in the same category. The number of categories was equal to number of exam questions in order to ensure that every student gets one question from each category by random selection.

There are 20 computers in the biggest computer classroom at our Faculty and approximately 60 students on each exam. Obviously, they could not all take exam at the same time, but they were organized in small groups which led to another possible problem enabling next group of students to solve the tasks via mobile phones while waiting for their preliminary exam. But access to LMS Moodle can be restricted to a certain range of IP addresses.

Another issue that had to be considered was the arrangement of computers in the classroom. Namely, the students were seated next to each other and therefore it was easy to see other people’s screens. However, question and answer order were shuffled and just one question at a time was visible on the screen. Furthermore, Moodle selects different questions for every exam, one from each category. Therefore, it is unlikely that the same question was displayed on two neighboring computers at the same time in the classroom. That is the main reason to have a large question database. Poggio and others suggested even avoiding questions long enough to require scrolling in order to see all parts of items’ stimuli (Poggio, 2005).

AAI @ EduHr is an infrastructure for the authentication and authorization within the system of science and higher education in the Republic of Croatia. So, every student at our university has his/her own unique electronic identity, with unique username and password to log in to different web applications, including Moodle. The problem of using a password is forgetting the password which prevents students from accessing exam (but it happened only a few times).

“Triple the amount of time it needs you to solve the exam” is a well-known tip for estimating how much time the student will need to complete the test. Root suggests even more detailed determination of needed time:

- 30 seconds per true-false item
- 60 seconds per multiple choice item
- 120 seconds per short answer item
- 10 to 15 minutes per essay question
- 5 to 10 minutes to review the work (Root, 2001).

The length of both computer-based parts of preliminary exams at the Faculty of Civil Engineering and Architecture Osijek was 15 minutes.

3.3. Test evaluation

The evaluation of computer-based test is one of the biggest advantages in comparison to paper-based test. The LMS automatically evaluate exam and results are almost immediately visible to all students (excluding essay question type). However, sometimes it is possible that students' answers are correct, but not recognized as correct ones by the system (particularly in relation to cloze type and short answer question type) due to lack of adequate instructions or if there are not specified all variants in correct answer settings (see example 5).

Example 5: The graph of each even function is symmetric with respect to ordinatu, y-os.

For instance, one student answered *ordinate, y axis*. In tasks' settings *ordinate* and *y axis* are two variants of correct answer, but both answers written together are not recognized as correct answer. Such cases then require manual scoring.

Figure 3 shows first preliminary exam score distribution for years from 2011 to 2018, excluding 2014 and 2015 when preliminary exams were paper-based exams. From 2011 to 2016 maximum score was 13 points. 2017 one more question was included in the exam, so the maximum score that year was 14 points and finally, last year one more question was added which increased maximum score by 1 point (a total of 15 points). There is a great variability over the years. Some generations of students have better scores. For example, 2013 even 15 students had 9-10 points, and 31 of them (more than 50 %) had more than 70 % of scores.

The results from Table 2 confirm our assumption that the first-year students in 2013 had the highest scores with average score 9.14 of 13 (69.23 %). The results were getting worse and worse since then, especially having in mind that last two years some more questions were included in the exam. If you want to compare the scores from different years, you must recalculate average score without added questions (in Table 2, under Modified average score). The results show decline in average score in 2018, 6.38 out of 13 (49.08 %).

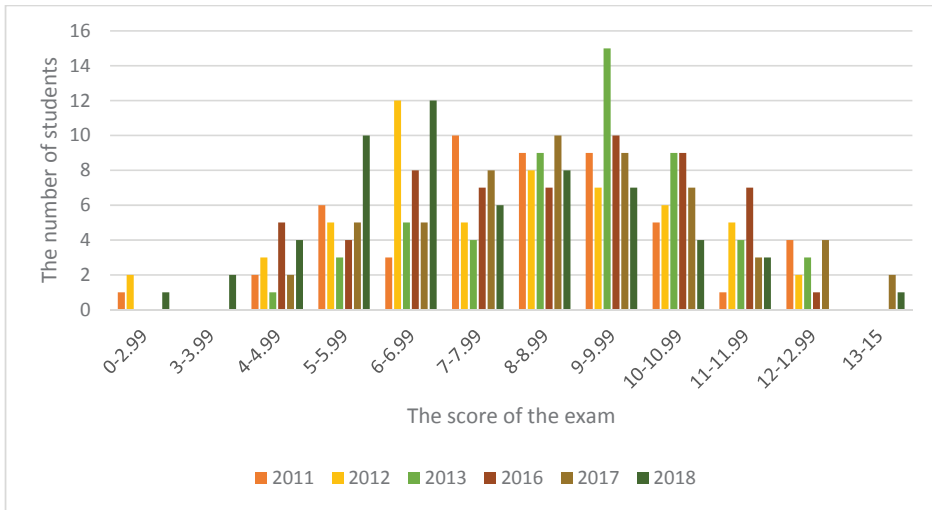

Figure 3. First preliminary exam score distribution for years from 2011 to 2018.

Table 2. Average scores over years.

Year	2011.	2012.	2013.	2016.	2017.	2018.
Average score	8.15	7.90	9.14	8.14	8.52	7.22
Modified average score					7.87	6.38

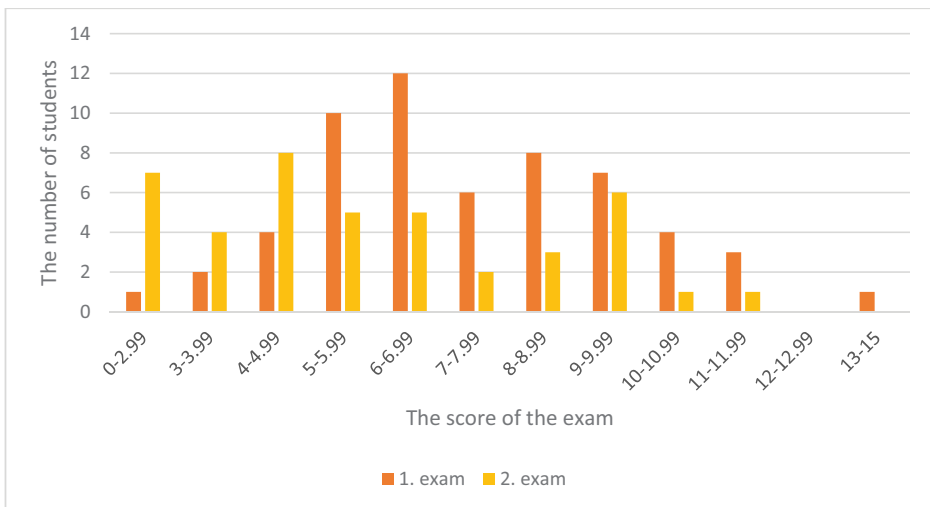

Figure 4. Comparison of the first and second preliminary exam results in 2018.

The results of theoretical parts of the first and second preliminary computer-based exams from 2018 are compared in the figure above. Figure 4 indicates better results of the first preliminary exam. The maximum score of the first preliminary exam was 15 and the maximum score of the second preliminary exam was 13. Table 1 shows total number of students taking the first preliminary exam (58 students), but only students who scored at least 30 % of points in the first exam were permitted access to the second preliminary exam (42 students). Average score for the first exam was 7.22 or 48.13 % (see Table 2) whereas average score for the second exam was 5.79 or 44.54 %.

3.4. Students' opinion about computer-based assessment

Last year, after the third preliminary paper-based exam, students (31 of them) were given a short questionnaire. The questionnaire was anonymous. Figure 5 presents only results about preliminary exams: majority of students (two thirds of them) prefer computer-based assessment to paper-based assessment and they find this type of assessment much more interesting. The numbers in Figure 5 represent percentages.

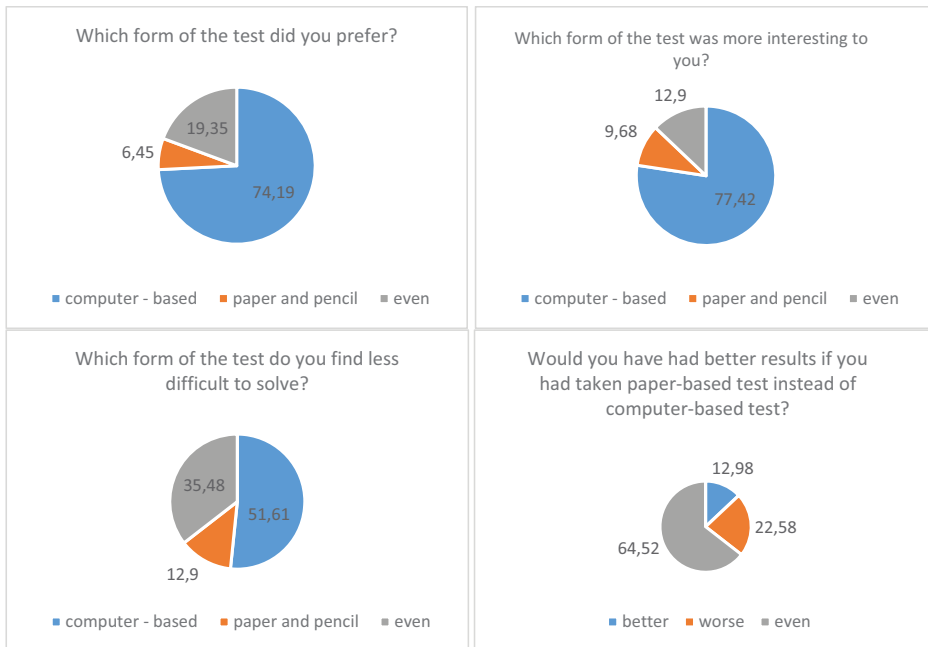

Figure 5. Students' opinion about computer-based assessment.

Half of them found computer-based exams less difficult to solve, and only 13 % of them found paper-based exam less difficult. Even 65 % of them think that they would achieve the similar results if the exam was paper-based.

They were also asked to give some suggestions (essay type question) for improving exams. Some of their comments were:

- “Everything is excellent; I have no further remarks”
- “I want easier questions”
- “Every theoretical part of preliminary exam should be computer-based”, etc.

The last comment was repeated several times.

4. Conclusion

This article deals with various challenges in using a computer-based test in the process of summative evaluation of students’ knowledge. It can be concluded that there are more benefits than disadvantages of such a test. First of all, it is easier to do a statistical analysis of group and individual results for each task. Questions can be grouped more easily and even (semi)automatically generated questions can be used. Furthermore, it is possible to include multimedia content.

The test results are immediately available to both teachers and students. Additionally, it is also possible to give certain feedback information to students; Moodle offers different kinds of feedback information. Finally, computer-based tests can reduce time (automatic scoring and grading) and costs (no printing of materials).

Last but not least, students have positive attitudes towards computer-based assessment. Almost 75 % of them prefer computer-based exams compared to only 6 % of students who prefer paper-based exams. Additionally, computer-based assessment is more interesting to the majority of students.

However, designing and creating exam tasks can be sometimes time consuming, especially if there is no adequate knowledge of tools needed to design such kinds of tests.

The question whether a computer-based test is less difficult than paper-based version, remains unanswered, but it could be an interesting topic for possible future research work. However, the students have divided opinions on that issue. Since there was no control group, the answer to this question couldn’t have been presented in this article.

The results revealed that the average score observed in these particular exams have dropped.

So, some future researches might also include the analysis of remaining paper-based exams in order to determine whether students’ performance also decreases over time, as well as possible reasons for lower students’ achievements.

Furthermore, a detailed statistical analysis could be performed on all test questions in order to determine their level of difficulty. LMS Moodle can help to find

out whether the questions are of an appropriate level of difficulty because it already provides some calculated statistical values.

In conclusion, objectives of introducing ICT into assessment are met. Computer-based exams have great impact on student satisfaction, and they make delivering, evaluating, and grading a quick process.

References

- [1] BACKES, B., COWAN, J. (2018). Is the Pen Mightier Than the Keyboard? The Effect of Online Testing on Measured Student Achievement. *National Center for Analysis of Longitudinal Data in Education Research*. Retrieved February 15, 2019 from <https://caldercenter.org/sites/default/files/WP%20190.pdf?platform=hootsuite>
- [2] MATOTEK, J. (2017). Mathematics attitudes among students of Civil Engineering. *Mathematics education as a science and profession*, 209–222, Zagreb: Element.
- [3] MIDGETT, C. W., & EDDINS, S. K. (2001). NCTM's Principles and Standards for School Mathematics: Implications for Administrators. *NASSP Bulletin*, 85(623), 35–42. DOI:10.1177/019263650108562305
- [4] NEWTON, P. E. (2007). Clarifying the purposes of educational assessment. *Assessment in Education: Principles, Policy and Practice*, 14(2), 149–170.
- [5] POGGIO, J., GLASNAPP, D. R., YANG, X., & POGGIO, A. J. (2005). A comparative evaluation of score results from computerized and paper and pencil mathematics testing in a large-scale state assessment program. *Journal of Technology, Learning, and Assessment*, 3(6).
- [6] ROOT, E. (2001). *Is This Trick Question?* Kansas State Department of Education. Retrieved February 23, 2019 from <https://www.k-state.edu/ksde/alp/resources/Handout-Module6.pdf> [Accessed 23/02/2019]
- [7] SANDENE, B., HORKAY, N., BENNETT, R. E., ALLEN, N., BRASWELL, J., KAPLAN, B., ORANJE, A. (2005). *Online Assessment in Mathematics and Writing*. U.S. Department of Education. Retrieved February 21, 2019 from <https://files.eric.ed.gov/fulltext/ED485780.pdf>
- [8] SHUDONG, W. (2004). *Online or Paper: Does Delivery Affect Results?* Pearson Education.
- [9] SUURTAMM, C., THOMPSON, D. R., DIAZ, L., KIM, R. Y., SAYAC, N., SCHUKAJLOW, S., SILVER, E., UFER, S., VOS, P. (2016). *Assessment in Mathematics Education: Large-Scale Assessment and Classroom Assessment. ICME-13 Topical Surveys*, Springer International Publishing. DOI: 10.1007/978-3-319-32394-7_1
- [10] SWAN, M., & BURKHARDT, H. (2012). A designer speaks: Designing assessment of performance in mathematics. *Educational Designer: Journal of the International Society for Design and Development in Education*, 2(5), 1–41.
- [11] WATSON, A., & OHTANI, M. (Eds.) (2015). *Task design in mathematics education. An ICMI Study 22*, Heidelberg, Germany: Springer.

- [12] WAY, W. D., DAVIS, L. L., FITZPATRICK, D. S. (2006). *Score Comparability of Online and Paper Administrations of the Texas Assessment of Knowledge and Skills*. Retrieved February 21, 2019 https://images.pearsonassessments.com/images/tmrs/Score_Comparability_of_Online_and_Paper_Administrations_of_TAKS_03_26_06_final.pdf
- [13] WILIAM, D. (2007). Keeping learning on track: Classroom assessment and the regulation of learning. In F. K. Lester, Jr. (Ed.), *Second handbook of research on mathematics teaching and learning*, 1053–1098, Charlotte, NC: Information Age Publishing.

Contact address:

Josipa Matotek
Faculty of Civil Engineering and Arhitecture
University of Osijek
Vladimira Preloga Street 3, 31000 Osijek, Croatia
e-mail: josipa.matotek@gfos.hr

Provjera znanja iz matematike na računalu na razini visokog obrazovanja

Josipa Matotek

Građevinski i arhitektonski fakultet, Sveučilište u Osijeku, Osijek, Hrvatska

Sažetak. Bitan dio nastavnog procesa je i evaluacija znanja studenata. U matematici na visokoškolskoj razini često se to vrednovanje provodi u dvije faze. Prva faza je procijena znanja rješavanja zadataka, a druga faza je procjena teroteskog znanja. Usljed sve većeg uvođenja informacijsko komunikacijskih tehnologija (IKT) u školski sustav na različite načine, sve je više primjera evaluacije znanja koristeći računala u svrhu testiranja znanja.

U ovom radu je opisano višegodišnje autorovo iskustvo u korištenju računala u svhu ispitivanja znanja. Autor je u sklopu svoje nastave iz kolegija Matematika za inženjere 1 na stručnom studiju na Građevinskom i arhitektonskom fakultetu koristio testove (u ispitivanju teoretskog znanja) kreirane u sustavu za upravljanje učenjem, Moodle-u, od 2011. godine. U radu će biti opisane razlike između klasičnih testova (pisanih na papiru) i testova koji se provode na računalima, pri tome misleći na bitno različite načine kreiranja pitanja i načine provedbe samog ispita. Nadalje, bit će komentirani rezultati ispita dobiveni na ovakav način te prikazani utisci studenata o ovakvom načinu provođenja ispita.

Cilj rada je istaknuti prednosti i nedostatke korištenja računala u testovima iz matematike na visokoškolskoj razini.

Gljučne riječi: evaluacija znanja, matematika, testovi na računalu, klasičan ispit, razina visokog obrazovanja

Technology use in early childhood

Ksenija Romstein

Faculty of Education, University of Osijek, Osijek, Croatia

Abstract. Modern childhood is closely connected to early use of technology such as Internet, especially Youtube, and different apps for smartphones and tablets. Recent researches revealed quite early start of technology use: children at the age of seven already use technology at everyday basis, and up to three hours a day. At the same time, parents use the same technologies parallel with their children, which parents consider as safety factor, i.e. parents think that their presence in the room during child being online makes their children safe from online threats. To find out how parents and preschool teachers perceive technology use in early childhood, for children up to seven years of age, online survey was conducted during November and December 2018 in Croatia. Overall 401 parents and preschool teachers from five Croatian counties participated in this survey. Results show that parents and preschool teachers consider technology in early education to be more useful and offering more potentials for children academic and social life, than it is a threat for their development. When they argue about potentials, they say technology can help a child in acquiring foreign language, acquiring competencies for appropriate use of technologies later in life, academic preparation for the school entrance, and knowledge about immediate surroundings. Majority of the parents and preschool teachers (85 %) would recommend a technology use not prior the third year of life, however, some parents and preschool teachers would consider a technology use for children in their first and second year of life. Majority of participants recommend one hour a day for technology in home, yet for several parents and teachers, even two or three hours a day would be appropriate for children under seven. These results reveal that parents and teachers can recognize benefits of technology in early education. Yet, they have to get information about other impacts of use of technology in early childhood, including its impact on language development and social skills in toddlers.

Keywords: early childhood, parents, preschool teachers, technology, benefits and risks

1. Introduction

Modern childhood is closely connected to early use of technology, as it is impossible to scrutinize contemporary childhood without technology and media. In the past 10 years, technology has increasingly been present in scientific literature, but also technology has become a part of the landscape and contexts of children's everyday lives (Jones and Park, 2015). Track-researches in European Union and United States of America (ENISA, 2014; CSM, 2017) have proven that technology is increasingly present in early years – even children under age of two are given tablets, mobile/smart-phones and different devices such as iPads for up to two hours a day. On the other hand, more “traditional” devices such as DVDs, television and video games/consoles are decreasing in everyday usage (Hipp, Gerhardstein, Zimmermann et al., 2017; CSM, 2017), suggesting that parents are oriented towards mobility and portable devices that can be used in different spaces and contexts. As far as socio-economic status is concerned, families with lower incomes have limited access to internet, yet the ownership of mobile devices such as smart phones or tablets is increasing, and according to CSM (2017) 61 % of families with low incomes have at least one portable device which is shared between parents and children, and children spent more than two hours per day on these devices. Children in middle income families spent similar amount of time on devices, and children in high-income families, as this report suggests, spent much lower amount of time on portable devices, less than hour and a half. The difference is still present in content – lower income families are restricted to online educational contents due to restricted access to internet (CSM, 2017), suggesting that quality of available contents should also be involved in the researches. Both European and USA track-research (CSM, 2017; ENISA, 2014) revealed continuous increasing in time-consuming of internet for young children under five years. The first encounter with media is in infancy, around four month of child's life, and its often TV screen involved (Reid Chassiakos, Radesky and Christakis, 2016). In their survey, 92 % of children under age of one have been introduced to tablets and smartphones. The overall time spent on screen is rapidly increasing during the first five years of life, so children under 7 years of age averagely spent around 7 hours per day on different electronic devices (American Academy of Pediatrics as cited in Jones and Park, 2015). This kind of time management slowly capturing interest of research community, shifting focus from researching adolescents and high-school users to identifying benefits and risks of online early childhoods. As risk of use of technology in early childhood, under age of seven, parents articulate possibility of online grooming and exposure to violence, while potential harms for child's development such as impact on cognitive abilities, language and social skills are not considered as risk factors by parents (CSM, 2017). On contrary, 83 % of parents in CSM 2017 survey claimed that there are more benefits of technology usage in early childhood, than risks. Authors Hipp, Gerhardstein, Zimmermann et al. (2017) see fewer benefits of technology in early years. They say that technology doesn't allow several important things for learning in early years, such as transfers from screen to reality, tactile input, and imitation which is a foundation for later learning in life. Instead of technology and screens, children under age of three should be given an opportunity to experience real-world interaction, i.e. to learn

about their immediate surroundings by participation and direct engagement with parents in situations of scaffolding (ibid.). According to track-research conducted in USA in 2017 by Common Sense Media, parents have mixed feelings about technology in early childhood. For instance, majority of parents agreed that technology benefits children in their development, especially on children's creativity, social skills and ability to maintain attention/focus. But, at the same time, parents are concerned about online violence and children's physical activity – parents are aware that screens can't compensate physical activities. Parents' views vary across the chronological age of children – parents of children under two years claim that technology benefits child's social skills, ability to focus and behavior in generally, parents of children aged three to six put emphasis on creativity, and parents of children aged six to eight see major benefits on creativity and social skills, while all three groups of parents agree that major contribution of technology in early years is learning (ibid.). Interesting, in this survey, lower income families reported higher level of interest for quality of apps and recommendations about children's media use, than parents from high-income families and higher level of education. This finding is similar to findings of Velki and Romstein (2019) which showed that higher educated internet adult users more often practice risk behaviors (such as revealing passwords and account information to third parties, opening different web sites without adequate security programs etc.), due to their theoretical knowledge about threats – they think that their knowledge about threats is enough to protect them, which is a paradox.

When preschool teachers and educators were asked about benefits and risks of technology in early childhood, their major concern was inappropriate online content and sexual abuse, similarly to parents' concerns (Jones and Park, 2015). As far as developmental risks are concerned, preschool teachers mention lack of creativity, and lower socio-emotional skills as major threats of technology in early years (ibid.). Also, problems deriving from technology in early years are obesity, poorer ability to concentrate on a task, and lack of adequate self-regulation skills needed during the interaction with peers and others in everyday life (Radesky, Silverstein, Zuckerman et al., 2014), suggesting that technology in early education could be a public health issue if not adequately managed. As major benefits of technology in early years, preschool teachers mention literacy acquisition and basic academic skills such as writing and spelling (Radesky, Silverstein, Zuckerman et al., 2014). They perceive technology in early childhood as helpful and useful, only if it is carefully used for learning purpose, and if closely monitored by caregivers (Blackwell, Lauricella and Wartella, 2014; Lauricella, Blackweel and Wartella, 2017). As Guernsey (2017) remarked, preschool teachers are more than parents concerned with content and context, suggesting that technology itself isn't much of a help without structure and adequate approach. Although technology in education is supported by policy makers, it is less present in early childhood education (Blackwell, Lauricella and Wartella, 2014), indicating that policies and recommendation for technology in education should be offered in more systematic way, connecting early education with other levels of education. This is needed because children acquire behavioral patterns in early years, and adequate approach to technology could have a preventive effect for reducing risk online behaviors in adulthood. Also, adults have an impact on children use of technology, so it is

important that policy makers, researchers, preschool teachers and parents closely collaborate on this issue, and to scrutinize risks and benefits of technology in early years.

2. Method

2.1. Goal and purpose of survey

The main goal and purpose of this survey was to identify benefits of technology in early childhood perceived by parents and preschool teachers.

2.2. Research question

In this survey, the research question was: How parents and preschool teachers perceive technology in early childhood, i.e. what are the main benefits of technology in early childhood perceived by parents and preschool teachers?

2.3. Participants

Overall 401 parents and preschool teachers from five Croatian counties participated in this survey: 212 parents (53.6 %) and 189 preschool teachers (47.1 %), both females (95 %) and males (5 %). Majority of participants were aged 21 to 30 (40.6 %), and 31 to 40 (31.2 %). As far as their educational level is concerned, majority of participants (65.3 %) reported high-school as their formal educational level. Majority of parents have one child under age of 7 in the family (87.2 %).

2.4. Questionnaire

For this purpose, online questionnaire was offered via google docs platform. Questionnaire consistent of three major parts: (1) general information about participants (their social role – parents or preschool teachers, their age, level of education, number of children in the family), (2) questions about benefits of technology in early childhood, and (3) habits of using technology in everyday life.

2.5. Data collection

Questionnaire was distributed through social media network, assuming that parents and preschool teachers who spent some amount of time online, would see the questionnaire and would participate in this survey. Data were collected during November and December 2018.

2.6. Data analysis

Due to qualitative aspects of survey, a mixed method approach was considered as suitable for data analysis.

3. Results and interpretation

3.1. Benefits of technology in early childhood

Table 1. Benefits of technology perceived by parents and preschool teachers.

Benefits	Parents (%)	Preschool teachers (%)
Learning foreign language	87.2	79.3
Learning how to use technology	61.3	60.8
Communication with others	15.1	9.5
Learning about immediate surroundings	36.3	13.2
Achieving school readiness (enhancing academic skills)	49.5	26.4

Parents and preschool teachers were given an opportunity to assess major benefits of technology in early childhood. They were asked to name several benefits in accordance to personal estimation of long-term positive outcomes for child's life and development. Both, parents and teachers have similar opinions about learning foreign language and learning how to use technology, yet they differ in benefits for communication with others, learning about immediate surroundings and achieving school readiness: preschool teachers see fewer benefits in those areas than parents. Similarities in assessing benefits on learning foreign language and how to use technology is logical, i.e. technology use can be learned only through direct experience, and foreign languages are becoming available through technology and media. Similar founding was presented by Radesky, Silverstein, Zuckerman et al. in 2014, and Jones and Park in 2015. In their researches, preschool teachers perceive major benefits in academic skills, especially in early literacy. The differences in this survey could be a result of perception of learning – preschool teachers are more aware than parents that communication and learning about immediate surroundings should be conducted through live, on-site communication, involving reciprocity and adequate feedback. Also, achieving school readiness involves different processes, so preschool teachers perceive technology less needed for this area of child's life, i.e. preschool teachers are aware that school readiness is multi-dimensional phenomenon and technology cannot completely meet all of the criteria needed. These differences could be interpreted within the levels of formal education because preschool teachers during their study learn on more comprehensive level about learning in early years, and parents don't have that kind of knowledge.

Table 2. Suitable technological platforms for achieving benefits.

Platforms	Parents (%)	Preschool teachers (%)
Youtube	32.1	13.2
Internet (in general)	53.3	51.8
Social media (Facebook, Tweeter)	0.2	–
Apps for smart-phones	49.5	46.6
Online games	14.2	–
Console games (Play Station, Nintendo etc.)	9.4	–

As most suitable platforms for achieving benefits, according to parents are internet, apps for smart-phones and Youtube, while preschool teachers prefer apps for smart-phones and internet. Parents even suggest social media, online games and console games as suitable technology platforms for early learning. Several authors (Blackwell, Lauricella, Wartella, 2014; Jones and Park, 2015) suggested that Youtube is adequate media, as reported by parents, because children can access quality educational content such as Sesame street. However, there are no research on social media in early childhood, which could be interesting to question because there are different social medias available. Also, it would be interesting to see how parents use it particularly in educational purpose, as here suggested.

Table 3. Suitable child's age for introduction of technology.

Child's age	Parents (%)	Preschool teachers (%)
During 1 st year of life	0.5	–
During 2 nd year of life	16.5	–
During 3 rd year of life	54.2	47.1
After 3 rd year of life or later	28.8	52.9

Preschool teachers and parents differ in perception of suitable age for introducing technology into child's life. While several parents consider 1st and 2nd year of life as age appropriate time for technology introduction, preschool teachers wouldn't recommend it before child's 3rd birthday. In Croatia there aren't any formal recommendations by experts, but American Academy of Pediatrics (2016) advice parents that children under age of 2 don't need technology and media to learn. Rather, children under two should get involved in the hands-on activities to develop adequate skills, and children aged 3 to 5 can get access to media and technology, but only if closely supervised by parents and professionals, and if content is educative and high-quality, such as Sesame Street (AAP, 2016). Differences in perception between parents and preschool teachers in this survey could be derived from formal education of preschool teachers within which they learn about child's development on scientific level, involving researches across disciplines covering speech, motor development, cognitive development etc.

3.2. Habits of using technology in everyday life

Table 4. Benefits of technology for parents and preschool teachers.

Benefits	Parents (%)	Preschool teachers (%)
Connecting with (other) parents	75.4	87.3
Connecting with colleagues and co-workers/ doing work from home	29.7	69.8
Getting an opportunity to conduct house work (cleaning, cooking, ironing etc.)	21.2	–
Learning about technology together with children	54.2	–

Both, parents and preschool teachers use technology for connecting with each other. Parents seek opportunities to exchange experiences with other parents, forming virtual peer-network which is inherent part of modern parenthood (Romstein, Despot and Zamečnik, 2016). Parents sometimes use technology as support during house work, for keeping children occupied, while they are cooking, cleaning etc. This practice is present amongst parents for quite some time – they use technology as some sort of virtual nanny while they are conducting daily routines in the households (Babić, Irović and Romstein, 2007). The main reason for that could be absence of support for parents, i.e. involvement of grandparents and unequal distribution of daily routines amongst family members (Romstein, Despot and Zamečnik, 2016). The differences could be interpreted in the context of social conditions and social roles indicated in this survey. Although preschool teachers don't use technology as an opportunity to conduct house works, it would be interesting to conduct research with emphasis on their parental roles, which could differ from their professional ones. Also, Croatian kindergarten are suffering from lack of money and majority of kindergarten struggle with basic didactical equipment, leaving technology at margins of educational work. Kindergartens in Croatia don't have tablets, PCs etc. as basic equipment, and majority of kindergartens have problems with internet connection, which could influence teacher's perception about technology use in early education.

Table 5. Amount of time child under 7 should spent with technology.

Time	Parents (%)	Preschool teachers (%)
Up to 30 minutes a day	34.9	54.4
Up to 60 minutes a day	40.1	21.8
From 1 hour to 2 hours a day	19.8	23.8
From 2 to 3 hours a day	4.7	–
More than 3 hours a day	0.5	–

Parents and preschool teachers have different opinions when it comes to time and length of use of technology in early years. In generally, preschool teachers tend to shorter amount of time, and perceiving the maximum of 1 to 2 hours as beneficial for child development. Parents are more likely to allow children greater amount

of time, some parents even more than three hours a day. American Academy of Pediatrics (2016) suggested that overall amount of time with technology at hands contributes, not just to problems in developmental status of a child, but also to health issues such as quality of night sleep and obesity. Therefore, they are recommending that parents and professionals educate themselves about educative potentials of technology, and to use it only for achieving educational goals, when identified. According to gathered data, preschool teachers are more likely to meet these recommendations, suggesting that formal education of preschool teachers contributed to their perception of benefits and risks of technology in early childhood.

4. Conclusion

This survey showed that Croatia follows global trends in use of technology in early childhood – there are some evidences that technology is offered to children during the first two years of life, with tendency to increase time of child's involvement with technology up to three hours a day. Similar founding has presented AAP (2016) and recommended parents to reconsider a practice of reducing on-screen activities for infants and toddlers. Founding suggests that young families in Croatia have to some extent *laissez faire* approach to technology, especially when it comes to scrutinizing adequate media for toddlers, and benefits of technology for child's development. The New Age Parents do their everyday activities online, including co-working and performing working tasks as part of their professional life. Contemporary life is fulfilled with technology, and children are introduced to technology early in life. Some researchers (Hipp, Gerhardstein, Zimmermann et al., 2017; Guernsey, 2017; Lauricella, Blackwell and Wartella, 2017) suggested that benefits of technology depend on quality of everyday interaction in immediate surroundings. So, if child is provided with enough real life experiences, risks of technology in early childhood are fewer. Therefore, parents and adults should provide balance between on-screen and on-hands activities in early childhood. In that task, collaboration between academic community, policy makers, educational professionals and parents is essential.

References

- [1] AAP Council on Communication and Media (2016). Media and Young Minds. *Pediatrics*, 38(5), 1–8.
- [2] BABIĆ, N., IROVIĆ, S., ROMSTEIN, K. (2007). Computer games, preschoolers, parents and preschool teachers' experience. In Nemeč, J. (Ed.), *The Evolution of Children's Play*, Brno: Faculty of Education, Masaryk University (CD-ROM).
- [3] BLACKWELL, C. K., LAURICELLA, A. R., WARTELLA, E. (2014). Factors Influencing Digital Technology Use in early Childhood Education. *Computer & Education*, 77(4), 82–90.

- [4] Common Sense Media (2017). *The Common Sense Census: Media Use by Kids Age Zero to Eight*. Retrieved April 1, 2019 from https://www.commonsensemedia.org/sites/default/files/uploads/research/csm_zerotoeight_fullreport_release2.pdf
- [5] ENISA (2014). *Roadmap for NS Education Program in Europe*. Madrid: ENISA.
- [6] GUERNSEY, L. (2017). Who's by Their Side? Question of Context Deepen the Research on Children and Media. In Barr, R., Linebarger, D. N. (Eds.), *Media Exposure During Infancy and Early Childhood* (pp. 25–32), New York: Springer.
- [7] HIPPE, D., GERHARDSTEIN, P., ZIMMERMANN, L. et al. (2017). The Dimensional Divide: Learning from TV and Touchscreens During Early Childhood. In Barr, R., Linebarger, D. N. (Eds.), *Media Exposure During Infancy and Early Childhood* (pp. 33–54), New York: Springer.
- [8] JONES, I., PARK, Y. (2015). Virtual Worlds: Young Children Using the Internet. In Heide, K. L., Renck Jalongo, M. (Eds.), *Young Children and Families in the Information Age: Application of Technology in Early Years* (pp. 3–15), New York: Springer.
- [9] LAURICELLA, A. R., BLACKWELL, C. K., WARTELLA, E. (2017). The “New” Technology, Environment: The Role of Content and Context on Learning and Development. In Barr, R., Linebarger, D. N. (Eds.), *Media Exposure During Infancy and Early Childhood* (pp. 1–24), New York: Springer.
- [10] RADESKY, J. S., SILVERSTEIN, M., ZUCKERMAN, B. et al. (2014). Infant Self-Regulation and Early Childhood Media exposure. *Pediatrics*, 35(5), 2013–2367.
- [11] REID CHASSIAKOS, Y., RADESKY, J., CHRISTAKIS, D. et al. (2016). Adolescents and Digital Media: Technical report. *Pediatrics*, 38(5), 1–18.
- [12] ROMSTEIN, K., DESPOT, S., ZAMEČNIK, S. (2016). Differences in Parental Perceptions of Parental Support in Croatia and Hungary. In Mlinarević, V., Vonta, T., Borovac, T. (Eds.), *Early and Prechool Education – Challenges and Perspectives* (pp. 135–143), Osijek: Faculty of Education.
- [13] VELKI, T., ROMSTEIN, K. (2019). User Risky Behavior and security Through Lifespan. *International Journal of Electrical and Computer Engineering Systems*, 9(2), 9–16.

Contact address:

Ksenija Romstein Faculty of Education
University of Osijek
Cara Hadrijana 10, 31000 Osijek, Croatia
e-mail: kromstein@foozos.hr

Uporaba tehnologije u ranom djetinjstvu

Ksenija Romstein

Fakultet za odgojne i obrazovne znanosti, Sveučilište u Osijeku, Osijek, Hrvatska

Sažetak. Moderno djetinjstvo je usko povezano s uporabom tehnologije kao što je primjerice Internet, posebice Youtube, te različite aplikacije za pametne telefone i tablete. Recentna istraživanja ukazuju kako se tehnologija u svakodnevnom životu djece pojavljuje već u ranom djetinjstvu: djeca u dobi od 7 godina svakodnevno rabe tehnologiju, do tri sata dnevno. Za to vrijeme roditelji također koriste tehnologiju, paralelno sa svojom djecom, što smatraju čimbenikom zaštite, tj. roditelji smatraju kako njihova fizička prisutnost u istoj prostoriji s djetetom koje je online smanjuje rizik od online zlostavljanja. Kako bi se saznalo više o tome kako odgojitelji i roditelji vide uporabu tehnologije u ranom djetinjstvu, tijekom studenog i prosinca 2018. u Republici Hrvatskoj je provedeno online ispitivanje. Ukupno 401 roditelj i odgojitelj iz pet županija su sudjelovali u ispitivanju. Rezultati pokazuju kako roditelji i odgojitelji smatraju da tehnologija u ranom djetinjstvu donosi djetetu koristi za razvoj akademskih i socijalnih vještina. Pojašnjavaju kako tehnologija može pomoći djetetu kod usvajanja stranog jezika, jačanju kompetencija uporabe tehnologije u kasnijem životu, te ju vide kao pomoć kod stjecanja znanja o neposrednom okruženju koja su potrebna kod polaska u osnovnu školu. Većina roditelja i odgojitelja (85 %) ne preporučuju uporabu tehnologije prije 3. godine, iako neki roditelji i odgojitelji smatraju kako je druga godina života najbolja za uvođenje tehnologije u djetetov svijet. Većina odraslih smatra kako je za optimalne učinke uporabe tehnologije dovoljan jedan sat dnevno, dok nekoliko roditelja i odgojitelja navode kako su dva ili tri sata uporabe tehnologije poželjne za djecu ispod sedam godina. Dobiveni rezultati pokazuju kako roditelji i odgojitelji prepoznaju potencijale tehnologije u ranom djetinjstvu, no isto tako da ih je potrebno dodatno informirati o utjecajima tehnologije na razvoj djece, posebice o utjecaju tehnologije na jezično-govorni razvoj i socijalne vještine djece rane dobi.

Cljučne riječi: rano djetinjstvo, roditelji, odgojitelji, tehnologija, dobrobiti i rizici

Index

- Abbitt, J. , 319
 Adachi, K. , 330
 Adebukola, O. R. , 331
 Adler, J. , 168
 Ahl, L. , 168, 168
 Ahtee, M. , 31, 33
 Alkhateeb, M. A. , 339
 Al-Duwairi, A. M. , 339
 Altrichter, H. , 267
 Altun, M. , 282
 Arslan, C. , 282
 Ambrus, A. , 282
 Ambrus, G. , 258
 Andačić, S. , 71
 Anning, A. , 31
 Anthony, J. L. , 339
 Apostol, E. M. D. , 282
 Archambault, L. , 319
 Asad, K. , 330
 Aslan, A. , 319
 Aurer, B. , 320
 Aydin, E. , 330
 Bü lter, H. , 31
 Babić , N. , 362
 Babo, L. , 340
 Backe-Neuwald, D. , 31
 Backes, B. , 352
 Baker, B. , 188
 Bakić, M. , 267
 Bakovljević, M. , 303
 Ball, D. L. , 5, 133
 Bass, H. , 133
 Barabash, M. , 71
 Baran, E. , 319
 Barlow, C. M. , 31
 Barquero, B. , 120
 Battista, Michael T. , 120, 144
 Batur, A. , 120
 Berquist, T. , 170
 Berry, J. S. , 33
 Bilinski, S. , 104
 Bintz, William P. , 120
 Bishop, Alan J. , 5, 121
 Blackwell, C. K. , 362
 Blau, I. , 319
 Blumer, H. , 31
 Bly, N. , 331
 Bokhove, C. , 339
 Bolandraftar, M. , 330
 Boon, P. , 339
 Bosch, M. , 120
 Braš Roth, M. , 291
 Breen, S. , 210
 Brown, M. , 168
 Bruce, D. C. , 71
 Bryans, M. B. , 170
 Buckley, L. , 31
 Burger, W. F. , 81, 144
 Burkhardt, H. , 210
 Bush, W. S. , 133
 Cabras, S. , 319
 Callaghan, V. , 321
 Campbell-Evans, G. , 267
 Carpenter, T. P. , 226
 Chai, C. , 319
 Chang S.H. , 221, 226
 Charalambous, C. Y. , 226
 Chavez, O. , 239
 Cheung, A. C. , 319, 339
 Chevallard, Y. , 188
 Chiang, P.-J. , 340
 Chigeda, A. L. , 340
 Choppin, J. , 168
 Christakis, D. , 363
 Chuang, H. H. , 319
 Clements, D. H. , 121, 144, 330, 339
 Cochran-Smith, M. , 267
 Cohen, D. K. , 5, 168
 Cohen, J. , 258
 Cohen, L. , 168, 210, 239
 Collins, K. M. T. , 168
 Confrey, J. , 188
 Cooper, T. , 121
 Cowan, J. , 352
 Crespo, S. , 168, 282
 Crippen, K. , 319
 Csík, C. , 258
 Cunningham, R. F. , 121
 Dahlgren Johansson, A. , 31
 Dakic, B. , 210
 Davis, E. A. , 168
 De Beni, R. , 31
 Delaney, S. , 226
 Dempsey, L. , 120
 Desimone, L. , 5
 Despot, S. , 363
 Dillon, P. , 320
 Dimmock, C. , 319
 Domović , V. , 168, 226
 Doorman, M. , 188, 339

- Downes, T. , 321
 Downey-Skochdopole, L. , 267
 Draženović-Žitko, V. , 171
 Draper, S. , 320
 Drijvers, P. , 339
 Duval, R. , 71, 188
 Dž umhur, Ž. , 144
 Eddins, S. K. , 352
 Eder, F. , 31
 Einarsdóttir, J. , 31
 Ejsing-Duun, S. , 331
 Elezovic, N. , 210
 Elia, I. , 188
 Ellis, A. B. , 188
 Empson, S. B. , 226
 Entwistle, N. , 320
 Ernest, P. , 31
 Evans, I. M. , 31
 Eysenck, M. W. , 31
 Eyyam, R. , 339
 Fan, L. , 168, 226, 239
 Faulder, M. , 340
 Fennema, E. , 226
 Findell, B. , 210
 Flojo, J. R. , 80
 Foong, P.Y. , 221, 226
 Foster, M. E. , 339
 Fraser, B. J. , 32
 French, M. J. , 267
 Fuys, D. , 144
 Gagatsis, A. , 188
 Gamst, G. , 321
 Gardner, M. , 321
 Gascó n, J. , 188
 Geddes, D. , 144
 Gerhardstein, P. , 363
 Gersten, R. , 80
 Ghasemi A. , 320
 Ghasemi A. , 320
 Gilbert, L. , 320
 Glasnapp, D. R. , 352
 Glasnović Gracin, D. , 32, 168, 188, 210, 226, 239
 Glazer, N. , 188
 Golac-Jakopović, I. , 171
 Goleš , B. , 171
 Graham, C. , 320
 Granda, W. V. , 330
 Grandgenett, N. F. , 320
 Gravemeijer, K. , 188, 339
 Gray, J. , 267
 Gregurović , M. , 291
 Grevholm, B. , 168, 240
 Grinstead, P. , 188
 Grouws, D. A. , 239
 Groves, S. , 210
 Gruehn, S. , 32
 Guetl, C. , 321
 Gueudet, G. , 170
 Guarino, A. , 321
 Guernsey, L. , 363
 Gulliford, A. , 340
 Gullo, D. F. , 330
 Gunnarsdóttir, G. H. , 168
 Gusić, J. , 188
 Gyori, J. G. , 267
 Haapasalo, L. , 239
 Hachich, N. , 80
 Hadar, L. L. , 239
 Haggarty, L. , 226, 240
 Halverscheid, S. , 32
 Handley, K. , 320
 Hallam, J. L. , 31
 Halverscheid, S. , 33
 Hannula, M. S. , 32
 Hartmann, J. , 71
 Harvey, S. T. , 31
 Hattermann, M. , 33
 Hawes, Z. , 71
 Hemenway, C. , 188
 Hemmi, K. , 168
 Henningsen, M. , 282
 Herbel-Eisenmann, B. A. , 168
 Herendiné Kónya, E. , 258
 Hesse, F. W. , 321
 Heymann, H. W. , 168
 Hiebert, J. , 121, 239
 Hill, H. C. , 133
 Hintze, S. , 71
 Hipp, D. , 363
 Hsu, H.-Y. , 226
 Hoelgaard, L. , 168
 Hohmann, M. , 71
 Holliman, A. , 331
 Houdement, C. , 71
 Hu, L. , 321
 Hubber, P. J. , 340
 Huberman, A. M. , 168
 Hutinski, Ž. , 320
 Imandoust, S. B. , 330
 Irović, S. , 362
 Jablonka, E. , 240
 Jakovljević Rogić, S. , 221, 226
 Jang, S. J. , 320
 Janssen, F. J. J. M. , 188
 Johansson, M. , 168
 Jojo, Z. M. M. , 71
 Jolley, R. P. , 31
 Jones, I. , 363
 Jordan, N. C. , 80
 Jovanović, K. , 321
 Jukić Matić , Lj. , 188, 226, 239
 Jurčec, L. , 226
 Kaeley, G. S. , 226
 Kadijevich, D. , 239
 Kamchedzera, E. , 340

- Kanoh, H. , 330
Karchmer-Klein, R. , 321
Kartika, H. , 339
Katalenić, A. , 188
Katona Gy. , 46
Kearney, K. S. , 32
Keitel, C. , 5
Kerel, K. , 320
Khorasani, M. K. , 339
Kidron, I. , 188
Kieran, C. , 188
Kilpatrick, J. , 5, 210
Klaić, F. , 81
Knobel, M. , 267
Koehler, M. , 320, 340
Koh, J. , 320
Koljonen, T. , 168, 168
Kontkanen, S. , 320
Kop, P. M. G. M. , 188
Kopp, E. , 267
Kosslyn, S. M. , 32
Kovács, Z. , 258
Kovačević, N. , 71
Kovarik, M. , 267
Krajcik, J. S. , 168
Krauskopf, K. , 321
Kucirkova, N. , 331
Kurnik Z. , 291
Kurt, S. , 339
Kuzle, A. , 32
Kuzniak, A. , 71
Kvaščev, R. , 303
Kwek, D. , 319
Laborde, C. , 188
Laine, A. , 32
Lankshear, C. , 267
Lauricella, A. R. , 363
Leatham, K. R. , 331
Lee, J. K. , 321
Lefevre, P. , 240
Leithwood, K. , 258
Lenhart, S. T. , 133
Lepik, M. , 240
Lesiczka, J. K. , 340
Leung, F. K.S. , 5
Levi, L. , 226
Liang, S. , 340
Lim L.G.P. , 221
Lin, Y.-W. , 340
Lipovača-Pjanić, K. , 144
Lobor, Z. , 171
Lodge, C. , 33
Loef Franke, M. , 226
Lopes, A. P. , 340
Lučić, Z. , 282
Lytle, S.L. , 267
Malchiodi, C. A. , 33
Mammana, C. , 33
Manion, L. , 168, 210, 239
Marchis, J. , 121
Marić, M. , 171
Markočić Dekanić, A. , 291
Markuš, M. , 291
Maruyama, Y. , 330
Mason, M. , 144
Matotek, J. , 352
Mattila, P. , 321
Mayring, P. , 168, 210
McDonnell, L. M. , 240
Mesa, V. , 226
Meyer, H. , 31
Messer, D. , 331
Meyers, L. S. , 321
Miao, Z. , 168, 239
Mićanović, M. , 267
Mišurac, I. , 291
Midgett, C. W. , 352
Miklec, D. , 221, 226
Miles, M. B. , 168
Millar, J. , 320
Milner, S. , 331
Misfeldt, M. , 331
Mishra, P. , 320, 340
Mitchelmore, M. C. , 71
Mladinić, P. , 188
Močnik, F. , 81
Moore, Sara D. , 120
Moos, R. H. , 33
Moos, B. S. , 33
Morrison, J. R. , 340
Morrison, K. , 168, 210, 239
Mouza, C. , 321
Mužić, V. , 240
Mudaly, V. , 188
Muir, T. , 267
Musser, G.L. , 81
Murphy, R. F. , 340
Nandakumar, R. , 321
Nason, R. , 120
Nemeth, T. , 171
Newton, P. E. , 352
Nicol, C. C. , 168
Ohtani, M. , 188
Olkun, S. , 127
Omolara, S. R. , 331
Onwuegbuzie, A. J. , 168
O'Shea, A. , 210
Ostler, E. , 210
Outhwaite, L. A. , 340
Ozden, S. Y. , 321
Pape, S. J. , 210
Park, Y. , 363
Pavković, M. , 188
Pazzaglia, F. , 31
Pearson, J. , 33
Pehkonen, E. , 33, 258
Pepin, B. , 226, 240
Pesti, C. , 267
Peter-Koop, A. , 33
Peterson, B. E. , 81

- Petrović, V. , 321
 Philipp, R. A. , 33
 Phyu, T. N. , 331
 Picker, S. H. , 33
 Pitchford, N. J. , 340
 Pitta, D. , 33
 Pjanić-Lipovača, K. , 144
 Poggio, J. , 352
 Popat, S. , 331
 Posch, P. , 267
 Potkonjak, V. , 321
 Pólya, Gy. , 282
 Presser, O. , 319
 Pribiš ev Beleslin, T. , 144
 Price, M. , 320
 Prok, I. , 104
 Prtajin, G. , 221
 Radesky, J. S. , 363
 Raiyn, J. , 330
 Ragan, D. M. , 72
 Reed, H. , 339
 Reid Chassiakos, Y. , 363
 Remillard, J. T. , 170
 Rampersad, R. , 188
 Reys, R.E. , 81
 Rezat, S. , 33
 Rich, P. J. , 331
 Richard, P. R. , 71
 Ring, K. , 31
 Rittle-Johnson, B. , 240
 Roberts, A. , 121
 Rolka, K. , 33
 Romano, D. , 144
 Romeo, J. , 321
 Romstein, K. , 363
 Root, E. , 352
 Roschelle, J. , 340
 Rosenberg, J. , 321
 Ross, S. M. , 340
 Roth, J. , 72
 Roth, W.-M. , 188
 Rowan, B. , 133
 Rukavina, S. , 267
 Russell, S.J. , 81
 Ruthven, K. , 188
 Ryve, A. , 168
 Sandene, B. , 352
 Sarama, J. , 121
 Schmidt, D. A. , 321
 Schmidt, W. H. , 240
 Schneider, M. , 240
 Schoenfeld, A. , 258
 Schoenfeld, A. , 210
 Sears, R. , 239
 Serrano, L. , 188
 Shahiri, A. M. , 331
 Shan Fu, J. , 321
 Sharma, M.C. , 268
 Shaughnessy, J. M. , 144
 Shield, M. , 240
 Shin, T. , 320
 Shudong, W. , 352
 Silverstein, M. , 363
 Sinclair, N. 72<<<
 Sidenvall, J. , 240
 Singh, L. K. , 340
 Skemp, R. R. , 72
 Slavin, R. E. , 319, 339
 Somekh, B. , 267
 Son, J.W. , 5
 Soria, V. M. , 239
 Spieza, V. , 321
 Sprent, P. , 258
 Stajčić, G. , 171
 Star, J. R. , 240
 Starkey, L. , 331
 Steele, M.D. , 121
 Stein, M. K. , 240
 Steinbach, R. , 258
 Stojanović, M. , 104
 Stylianides, G. J. , 240
 Sumpter, L. , 31
 Suurtamm, C. , 352
 Swafford, J. , 210
 Swan P. , 46
 Swan, M. , 352
 Sweeney, T. , 321
 Sweller, J. , 258
 Szirmai, J. , 104
 Szitányi, J. , 258
 Tan, L. , 319
 Tarr, J. E. , 239
 Taylan, R. D. , 239
 Tena Horrillo, J. D. , 319
 Thomas, L. , 331
 Thomson, P. , 34
 Thurlings, M. , 322
 Tiberghien, A. , 188
 Tibi, M. , 330
 Tikkanen, P. , 31
 Tischler, R. , 144
 Tkalec, V. , 72
 Toh, Y. , 319
 Torres, C. , 340
 Trickett, E. J. , 34
 Trigueros, M. , 188
 Trimble, H. , 121
 Tsai, C.-C. , 319
 Tseng, S.-C. , 322
 Tucker, T. , 121
 Tulving, E. , 34
 Tuohilampi, L. , 34
 Tuzson, Z. , 282
 Ualesi, Y. , 331
 Ursa, A. I. , 72
 Usiskin, Z. , 144
 Valtonen, T. , 322
 Valverde, G. A. , 170, 226, 242
 van Driel, J. H. , 188
 Van Olphen, M. , 322

- Van Steenbrugge, H. , 170
Van de Walle, J. , 34
Vandebrouck, F. , 188
Veale, A. , 34
Velki, T. , 363
Verschaffel, L. , 191
Viholainen, A. , 240
Villani, V. , 33
Voogt, J. , 322
Vuković, M. , 171
Walls, F. , 34
Wang, S. K. , 322
Wang, C. , 210
Wartella, E. , 362
Watson, A. , 191, 296, 352
Way, W. D. , 352
Weber, S. , 34
White, P. , 71
Wiliam, D. , 352
Winter, H. , 34
Wintsche G. , 46
Wittmann, E. Ch. , 34
Wright, P. , 120
Wong O. H. , 221, 226
Yan, E. , 31
Yara, P. O. , 268
Yaratan, H. S. , 339
Yazgan, Y. , 282
Yeo, J. , 210
Yeo, J. B. W. , 210
Zahedias S. , 320
Zahn, C. , 321
Zambo, D. , 34
Zamečnik, S. , 363
Zhu, Y. , 170
Zhu, C. , 319
Zimmermann, L. , 363
Zoričić, M. , 81
Zubac, I. , 144
Zuckerman, B. , 363
Zwart, D. P. , 340

Publisher:

ELEMENT d.o.o., Zagreb, Menčetićeva 2
www.element.hr
element@element.hr

Design:

Zdenka Kolar-Begović
Ružica Kolar-Šuper

Technical editor:

Sandra Gračan, dipl. inž.

Prepress and printed by:

ELEMENT, Zagreb

A CIP catalogue record for this book is available from the National and University Library
in Zagreb under 001030544.

ISBN 978-953-197-517-9

ELEMENT

